



Fuse Terminal Blocks for Blade-Type Fuses
acc. to DIN 72581-3f, ISO 8820-3, Series 2002

0.25 – 2.5 (4) mm ² ① AWG 22 – 12 400 V/6 kV/3 I _N 10 A ② Terminal block width 5.2 mm / 0.205 in  10 – 12 mm / 0.43 in	0.25 – 2.5 (4) mm ² ① AWG 22 – 12 400 V/6 kV/3 I _N 10 A ② Terminal block width 5.2 mm / 0.205 in  10 – 12 mm / 0.43 in
---	---



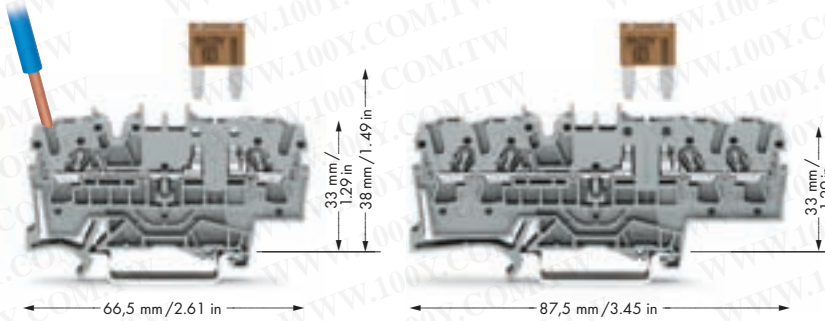
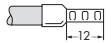

① can be connected: 0.25 mm² – 4 mm² "s+f-st";
 can be pushed in directly: 0.75 mm² – 4 mm² "s" and
 0.75 mm² – 2.5 mm² "insulated ferrule,
 12 mm/0.472 in"



勝特力材料 886-3-5753170
 勝特力电子(上海) 86-21-34970699
 勝特力电子(深圳) 86-755-83298787
[Http://www.100y.com.tw](http://www.100y.com.tw)



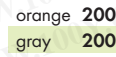

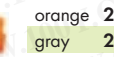





Item no.	Pack. unit	Item no.	Pack. unit
2-conductor fuse terminal blocks		4-conductor fuse terminal blocks	
gray 2002-1681		gray 2002-1881	
② - Individual arrangement: 10 A - Block arrangement: 5 A Please note touchproof protection from 42 V		② - Individual arrangement: 10 A - Block arrangement: 5 A Please note touchproof protection from 42 V	

Article-specific accessories

End and intermediate plate , 1 mm/0.039 in thick  orange 2002-1692 100 (4 x 25)  gray 2002-1691 100 (4 x 25)	End and intermediate plate , 1 mm/0.039 in thick  orange 2002-1892 100 (4 x 25)  gray 2002-1891 100 (4 x 25)
---	---

Accessories Series 2002

Appropriate marker systems: **WMB/Marker Strips/WMB Inline** (see Full Line Catalog W4, Vol. 1, Sec. 14)

Insulation stop , 5 pcs/strip 200 strips  light gray 2002-171 0.25-0.5 mm ² dark gray 2002-172 0.75-1 mm ²	Protective warning marker , with high voltage symbol, black, for 5 terminal blocks  yellow 2002-115 100 (4 x 25)	The rated currents of the fuse cartridges are defined differently in international standards. Due to the different current rating definitions, the recommended current-carrying permanent capacity of the fuses is max. 80% of their rated current according to DIN 72581 part 3 (for an ambient operating temperature of 23 °C). Selecting the correct fuse cartridge is important for product safety within applications as well as the service life/operational reliability of the fuse cartridges. Fuse cartridges can operate perfectly as protection (break-off point) if they are properly selected and are used in accordance with the manufacturers specifications. In general it is necessary to test fuse cartridges under normal conditions and operational failures within your application. With regard to the product safety, it is in general necessary to test the fuse in the appliance under normal conditions and operational failures.
Push-in type jumper bars , light gray, insulated, I _N 25 A  2-way 2002-402 200 (8 x 25) 3-way 2002-403 200 (8 x 25) 4-way 2002-404 200 (8 x 25) 5-way 2002-405 100 (4 x 25) : : 10-way 2002-410 100 (4 x 25)	Staggered jumpers , light gray, insulated, I _N 25 A  2-way 2002-472 100 (4 x 25) 3-way 2002-473 100 (4 x 25) 4-way 2002-474 100 (4 x 25) 5-way 2002-475 50 (2 x 25) : : 12-way 2002-482 50 (2 x 25)	
Push-in type jumper bars , light gray, insulated, I _N 25 A  1 - 3 2002-433 200 (8 x 25) 1 - 4 2002-434 200 (8 x 25) 1 - 5 2002-435 100 (4 x 25) : : 1 - 10 2002-440 100 (4 x 25)	Test plug adapter , for test plug Ø 4 mm/0.157 in  2009-174 100 (4 x 25)	
Modular TOPJOB®S connector , for jumper contact slot  1 pole 2002-511 100 (4 x 25)	Two-way marking adapter , pivotable  2002-121 50 (2 x 25)	
Spacer, modular 2002-549 100 (4 x 25)		
Blade-type fuses acc. to DIN 72581-3f / ISO 8820-3 (not offered by WAGO) 	Test plug , with cable 500mm/1'7.7", Ø 2 mm/0.079 in  red 210-136 50 (5 x 10)	

Fuse Disconnect Terminal Blocks with Pivotal Fuse Holder, 2.5 (4) mm²/AWG 12, for Miniature Metric Fuses 5 x 20 mm, Series 2002

VOLUME 1

0.25 – 2.5 (4) mm² | AWG 22 – 12
 250 V/6 kV/3 ①
 6.3 A ②
 Terminal block width 6.2 mm / 0.244 in
 10 – 12 mm / 0.43 in

0.25 – 2.5 (4) mm² | AWG 22 – 12
 250 V/6 kV/3 ①
 6.3 A ②
 Terminal block width 6.2 mm / 0.244 in
 10 – 12 mm / 0.43 in

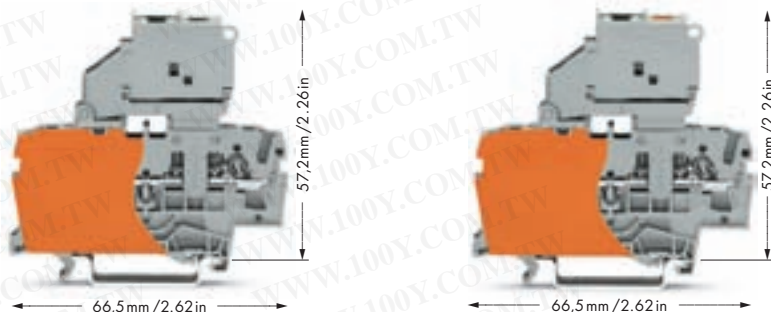

- ① 800 V = rated voltage
 8 kV = rated surge voltage
 3 = pollution degree
 (see also Full Line Catalog W4, Volume 1, Section 15)
- ② Nominal voltage and current are given by the LED or fuse
- ③ Leakage current in case of blown fuse: LED 6 mA

Description	Item no.	Pack. unit	Item no.	Pack. unit
Fuse disconnect terminal block with pivotal fuse holder, for DIN 35 rail,			2-conductor fuse terminal block with end plate, without blown fuse indication	
for miniature metric fuses	5 x 20 mm	gray	2002-1611	50
	5 x 20 mm		gray 12 – 30 V ≈ ③ 2002-1611/1000-541	50
	5 x 20 mm		gray 30 – 65 V ≈ ③ 2002-1611/1000-542	50
			gray 110 – 250 V ≈ 2002-1611/1000-836	50



Article-specific accessories

Description	Item no.	Pack. unit	Description	Item no.	Pack. unit
End plate for fuse terminal blocks, 2 mm/0.079 in thick			End plate for fuse terminal blocks, 2 mm/0.079 in thick		
gray	2002-991	100 (4x25)	gray	2002-991	100 (4x25)
orange	2002-992	100 (4x25)	orange	2002-992	100 (4x25)









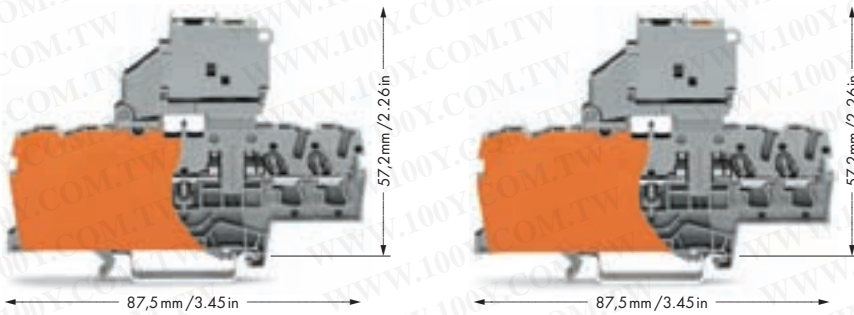



Accessories

Appropriate marker systems: **WMB/Marker Strips/WMB Inline** (see Full Line Catalog W4, Volume 1, Section 14)

Description	Item no.	Pack. unit	Description	Item no.	Pack. unit
Insulation stop, 5 pcs/strip		200 strips	Insulation stop, 5 pcs/strip		200 strips
light gray	2002-171	0.25-0.5 mm ²	light gray	2002-171	0.25-0.5 mm ²
dark gray	2002-172	0.75-1 mm ²	dark gray	2002-172	0.75-1 mm ²
		must be singularized			must be singularized
Protective warning marker, with high voltage symbol, black, for 5 terminal blocks			Protective warning marker, with high voltage symbol, black, for 5 terminal blocks		
yellow	2002-115	100 (4 x 25)	yellow	2002-115	100 (4 x 25)
		must be singularized			must be singularized
Push-in type jumper bars, light gray, insulated, I_N 25 A			Push-in type jumper bars, light gray, insulated, I_N 25 A		
2-way	2004-402	200 (8 x 25)	2-way	2004-402	200 (8 x 25)
3-way	2004-403	200 (8 x 25)	3-way	2004-403	200 (8 x 25)
4-way	2004-404	200 (8 x 25)	4-way	2004-404	200 (8 x 25)
5-way	2004-405	100 (4 x 25)	5-way	2004-405	100 (4 x 25)
:	:		:	:	
10-way	2004-410	100 (4 x 25)	10-way	2004-410	100 (4 x 25)
Push-in type jumper bars, light gray, insulated, I_N 25 A			Push-in type jumper bars, light gray, insulated, I_N 25 A		
1 - 3	2004-433	200 (8 x 25)	1 - 3	2004-433	200 (8 x 25)
1 - 4	2004-434	200 (8 x 25)	1 - 4	2004-434	200 (8 x 25)
1 - 5	2004-435	100 (4 x 25)	1 - 5	2004-435	100 (4 x 25)
:	:		:	:	
1 - 10	2004-440	100 (4 x 25)	1 - 10	2004-440	100 (4 x 25)
Test plug, with cable 500 mm/1'7.7", ∅ 2 mm/0.079 in ∅			Test plug, with cable 500 mm/1'7.7", ∅ 2 mm/0.079 in ∅		
red	210-136	50 (5 x 10)	red	210-136	50 (5 x 10)

0.25 – 2.5 (4) mm ² 250 V/6 kV/3 ① 6.3 A ② Terminal block width 6.2 mm / 0.244 in  10 – 12 mm / 0.43 in	AWG 22 – 12	0.25 – 2.5 (4) mm ² 250 V/6 kV/3 ① 6.3 A ② Terminal block width 6.2 mm / 0.244 in  10 – 12 mm / 0.43 in	AWG 22 – 12	Application notes



Item no.	Pack. unit	Item no.	Pack. unit
4-conductor fuse terminal block with end plate, without blown fuse indication		4-conductor fuse terminal blocks with end plate, with blown fuse indication by LED	
gray	2002-1811 50	gray 12 – 30 V ≈ ③	2002-1811/1000-541 50
		gray 30 – 65 V ≈ ③	2002-1811/1000-542 50
		gray 110 – 250 V =	2002-1811/1000-836 50
End plate for fuse terminal blocks, 2 mm/0.079 in thick  gray 2002-991 100 (4x25) orange 2002-992 100 (4x25)		End plate for fuse terminal blocks, 2 mm/0.079 in thick  gray 2002-991 100 (4x25) orange 2002-992 100 (4x25)	
Appropriate marker systems: WMB/Marker Strips/WMB Inline (see Full Line Catalog W4, Volume 1, Section 14)			
Insulation stop, 5 pcs/strip 200 strips  light gray 2002-171 0.25-0.5 mm ² dark gray 2002-172 0.75-1 mm ² must be singularized		Insulation stop, 5 pcs/strip 200 strips  light gray 2002-171 0.25-0.5 mm ² dark gray 2002-172 0.75-1 mm ² must be singularized	
Protective warning marker, with high voltage symbol, black, for 5 terminal blocks  yellow 2002-115 100 (4 x 25) must be singularized		Protective warning marker, with high voltage symbol, black, for 5 terminal blocks  yellow 2002-115 100 (4 x 25) must be singularized	
Push-in type jumper bars, light gray, insulated, I_N 25 A  2-way 2004-402 200 (8 x 25) 3-way 2004-403 200 (8 x 25) 4-way 2004-404 200 (8 x 25) 5-way 2004-405 100 (4 x 25) : : 10-way 2004-410 100 (4 x 25)		Push-in type jumper bars, light gray, insulated, I_N 25 A  2-way 2004-402 200 (8 x 25) 3-way 2004-403 200 (8 x 25) 4-way 2004-404 200 (8 x 25) 5-way 2004-405 100 (4 x 25) : : 10-way 2004-410 100 (4 x 25)	
Push-in type jumper bars, light gray, insulated, I_N 25 A  1 - 3 2004-433 200 (8 x 25) 1 - 4 2004-434 200 (8 x 25) 1 - 5 2004-435 100 (4 x 25) : : 1 - 10 2004-440 100 (4 x 25)		Push-in type jumper bars, light gray, insulated, I_N 25 A  1 - 3 2004-433 200 (8 x 25) 1 - 4 2004-434 200 (8 x 25) 1 - 5 2004-435 100 (4 x 25) : : 1 - 10 2004-440 100 (4 x 25)	
Test plug, with cable 500 mm/1'7.7", Ø 2 mm/0.079 in Ø  red 210-136 50 (5 x 10)		Test plug, with cable 500 mm/1'7.7", Ø 2 mm/0.079 in Ø  red 210-136 50 (5 x 10)	

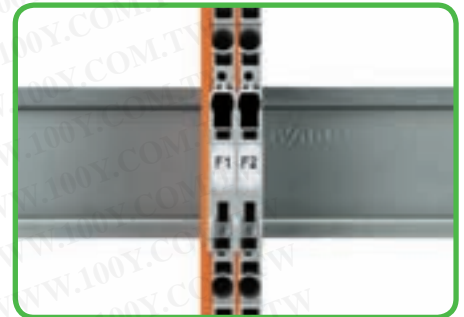

Fuse terminal blocks with a width of 6.2 mm/0.244 in can be assembled adjacent to each other. At the end of an assembly, if there is no adjacent fuse or disconnect terminal block, an end plate for fuse terminal blocks must be used.

When selecting miniature metric fuses, the maximum power loss listed below should not be exceeded. The power loss is determined according to IEC or EN 60947-7-3/VDE 0611-6 at 23 °C. The temperature rise of the terminal blocks must be checked according to their application and mounting. Higher ambient temperatures represent an additional impact on miniature metric fuses. Therefore, in such applications the rated current must be reduced if necessary. More details from the manufacturer.

Miniature metric fuses 5 x 20

Series Item No.	Overload and short circuit protection		Short circuit protection only	
	Individual arrangement	Group arrangement	Individual arrangement	Group arrangement
Fuse terminal blocks				
2002-1611				
2002-1811	1.6 W	1.6 W	2.5 W	2.5 W
2002-1811/.....				
2002-1611/.....	1.6 W	1.6 W	2.5 W	2.5 W

Protective warning marker and insulation stop must be singularized. Due to the 6.2 mm/0.244 in width of the fuse terminal blocks with pivotable fuse holder, 2004 Series jumpers must be used.

	250 V max.* 6.3 max.	* Electrical ratings are given by the fuse or nominal voltage of the indicator lamp respectively.
--	-------------------------	---

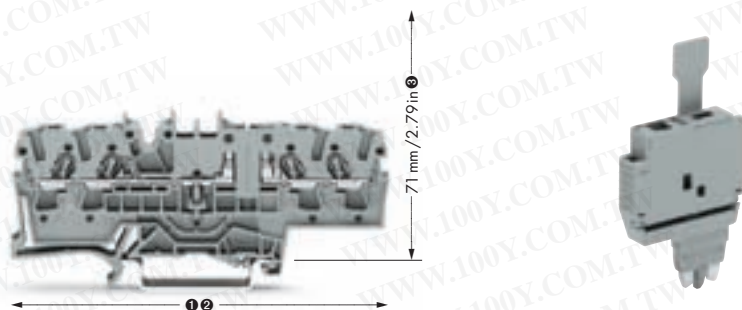

勝特力材料 886-3-5753170
 勝特力电子(上海) 86-21-34970699
 勝特力电子(深圳) 86-755-83298787
[Http://www.100y.com.tw](http://www.100y.com.tw)

Open side of terminal block	Description	Item no.	Pack. unit
	Fuse plug, for miniature metric fuses 5 x 20 mm	6.1 mm/0.24 in width with pull-tab 2004-0911	50
	Fuse plug, same as above, with additional indicator lamp, LED, AC/DC 12 – 30 V, LED, AC/DC 30 – 65 V, can be used in both switching directions	6.1 mm/0.24 in width with pull-tab 2004-0911/1000-0541 2004-0911/1000-0542	50 50
	AC/DC 120 V – 230 V	6.1 mm/0.24 in width with pull-tab 2004-0911/1000-0836	50

The use of pluggable fuse holders with rail mounted terminal blocks for protection of control circuits offers many advantages to the user since the function and the wiring are accomplished by two separate parts:

- no additional cost for assembly and wiring
- no risk of accidental contact with live parts during disconnection of fuse plug
- in case of exchanging a defective fuse the fuse plug is completely separated from the carrier terminal block
- therefore safe exchange of the fuse away from current carrying parts
- the fuse plug can be taken away by the serviceman avoiding unintentional reclosing of the circuit by another person
- quick exchange of a fuse by using a prepared "stand-by plug."

Further advantages:

- optional LED indicates blown fuse
- marking facility on the fuse plug for clear coordination to the correct carrier terminal block (WSB-Quick Marking System 4 mm/0.157 in)
- two touchproof test slots
- high density with only 6,1 mm/0.24 in width of terminal block/fuse plug
- instead of a fuse, a shorting link may be used as a disconnect plug.

When corresponding Neutral-circuit is adjacent to a fuse plug, a 5.2 mm/0.205 in wide space saving terminal block may be used, as a 6.1 mm/0.24 in fuse plug may overlap the terminal block.

See diagram below.

Miniature metric fuses 5 x 20

Series Item No.	Overload and short circuit protection		Short circuit protection only	
	Individual arrangement	Group arrangement	Individual arrangement	Group arrangement
Fuse terminal blocks				
2004-0911				
2004-0911/.....	1.6 W	1.6 W	2.5 W	2.5 W

Terminal blocks and accessories			
Appropriate marker systems: Terminal block WMB/Marker Strips			
	2-conductor carrier terminal block ① , 0.25–2.5 (4) mm ² /AWG 22–12 Stripped length 9–10 mm/0.37 in	Terminal block width 5.2 mm/0.205 in gray 2002-1661	50
	End and intermediate plate, for 2-cond. carrier term. block Item No. 2002-1661	1 mm/0.039 thick orange 2002-1692 gray 2002-1691	100 (4 x 25) 100 (4 x 25)
	4-conductor carrier terminal block ② , 0.25–2.5 (4) mm ² /AWG 22–12 Stripped length 10–12 mm/0.43 in	Terminal block width 6 mm/0.236 in gray 2002-1861	50
	End and intermediate plate, for 4-cond. carrier term. block Item No. 2002-1861	1 mm/0.039 thick orange 2002-1892 gray 2002-1891	100 (4 x 25) 100 (4 x 25)
	Shorting link, 5 x 20 mm, 6.3 A, if the fuse plug is used as disconnect plug	281-503	250 (10 x 25)
	End plate for fuse plug	2 mm/0.079 thick orange 2002-0991 gray 2002-0992	100 (4 x 25) 100 (4 x 25)

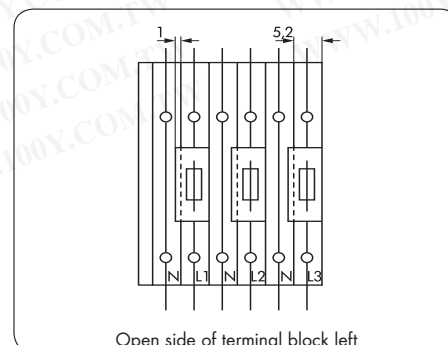

Open side of terminal block left

① 66.5 mm/2.62 in (2-conductor)
② 87.5 mm/3.45 in (4-conductor)
③ with inserted fuse plug