

# TJ-048A

size:0.48

unit:mm(inch)

# TJ serise PCB Probe

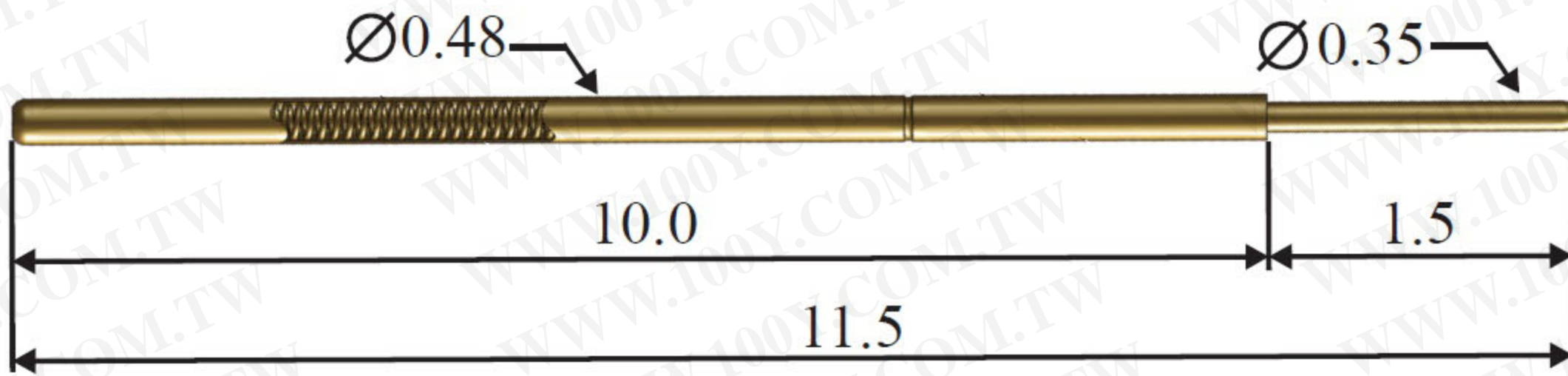

## Plunger Tips

01	90°	Ø0.35	02	30°	Ø0.35
04		Ø0.35	05	Pitch:0.1	Ø0.35
★06		Ø0.6	10		Ø0.35
11	90°	Ø0.6	12		Ø0.6
15	Pitch:0.35	Ø0.35	20		Ø0.65
★28	30°	Ø0.6			

勝特力材料 886-3-5753170  
 勝特力电子(上海) 86-21-54151736  
 勝特力电子(深圳) 86-755-83298787  
[Http://www.100y.com.tw](http://www.100y.com.tw)

## How to Order (★ Customized)

<b>TJ</b>	<b>-048</b>	<b>A</b>	<b>01</b>	<b>A</b>	<b>035</b>	<b>045</b>	<b>A</b>
Series	Size	Length	Tip	Tip Plating	Outer	Spring Force	Tube Plating
				A:Gold ★R:Rh			A:Gold ★N:Nickel Silver

# Timejet TR-048A

size:0.62  
unit:mm(inch)

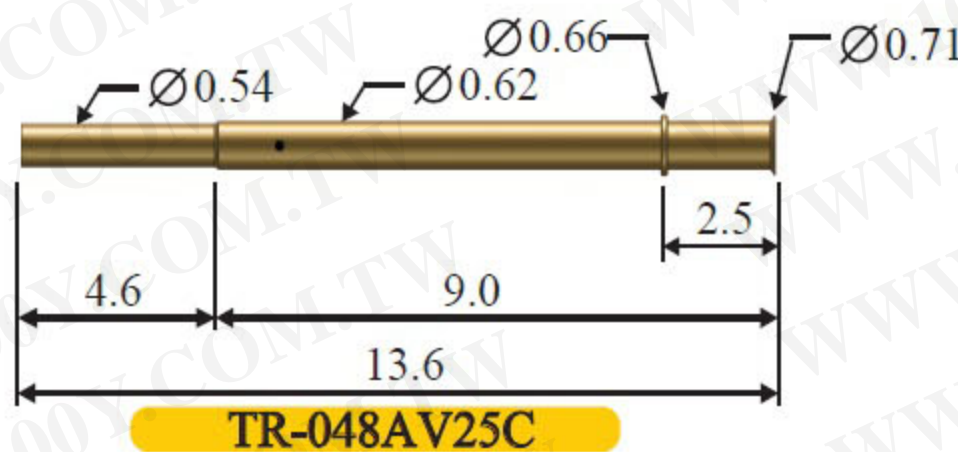

TR-048AV25C

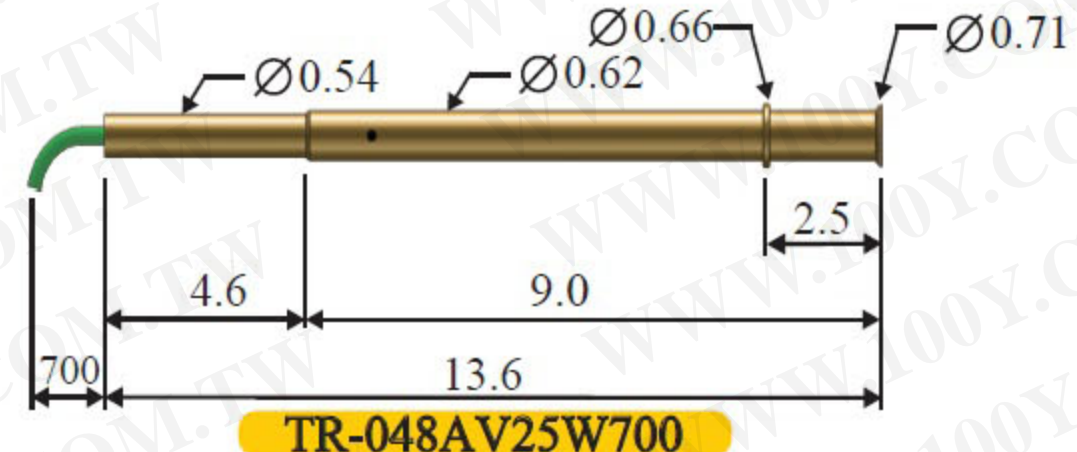

TR-048AV25W700

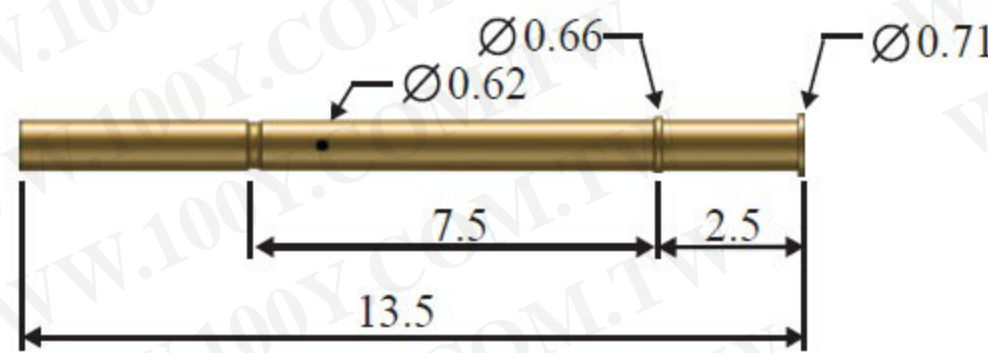

★ TR-048AVC25C

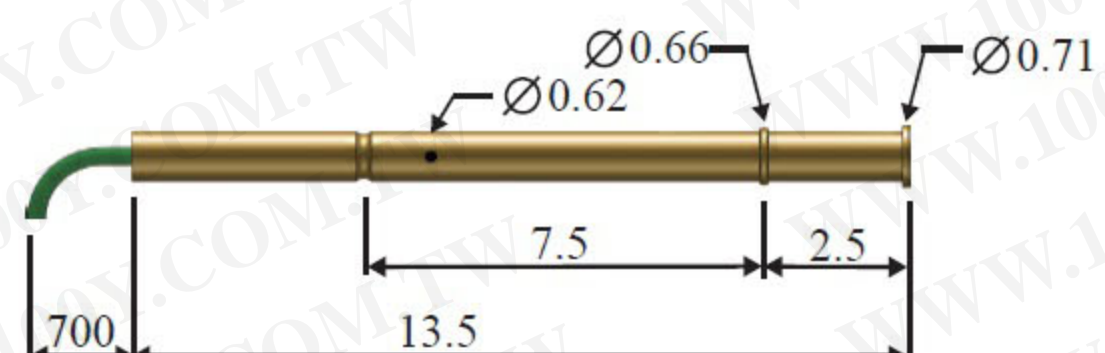

★ TR-048ACV25W700

## How to Order (★ Customized)

<b>TR</b>	<b>-048</b>	<b>A</b>	<b>V</b>	<b>25</b>	<b>C</b>	<b>70</b>
Series	Size	Length	Style	Distance of Press-Ring	Terminal	Wire-Length
			V:V type 1 Ring ★VC:V type 1 Ring by CNC	25:2.5	C:Crimp W:Wire Wrap	70:700mm

### Material Data

針軸 Plunger  
 高碳鋼鍍金 SK4 with Gold Plated  
 內管 Barrel  
 磷青銅鍍金 Phosphor Bronze with Gold Plated  
 彈簧 Spring  
 琴鋼線鍍金 Music Wire with Gold Plated  
 外管 Receptacle  
 黃銅鍍金 Brass with Gold Plated

### Electrical Data

最小中心距 Min. Center  
 0.85mm ( 0.0335" )  
 建議鑽孔尺寸 Recommended Hole Size  
 0.65mm ( 0.0256" )  
 額定電流 Current Rating  
 1A ( 安培 )  
 接觸電阻 Contact Resistance  
 150mΩ ( 毫歐姆 )

### Mechanical Data

工作行程 Working Stroke  
 1mm ( 0.3937" )  
 最大行程 Maximum Stroke  
 1.5mm ( 0.0590" )  
 行程彈力 Spring Force at Working Stroke  
 45g

# TJ-048B&C

size:0.48

unit:mm(inch)

# TJ serise PCB Probe

**TJ-048B**

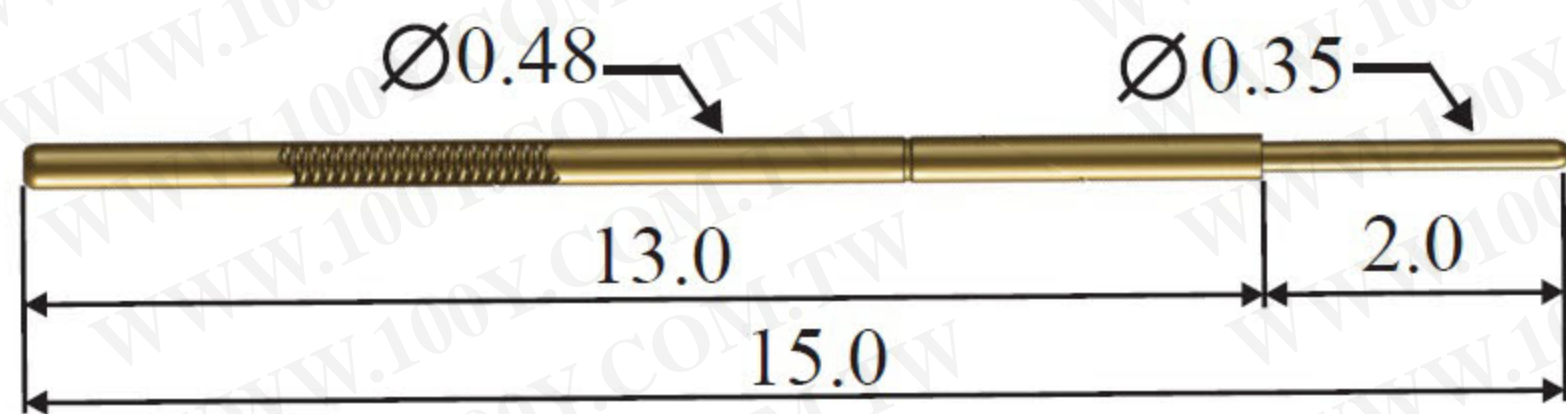

**TJ-048C**

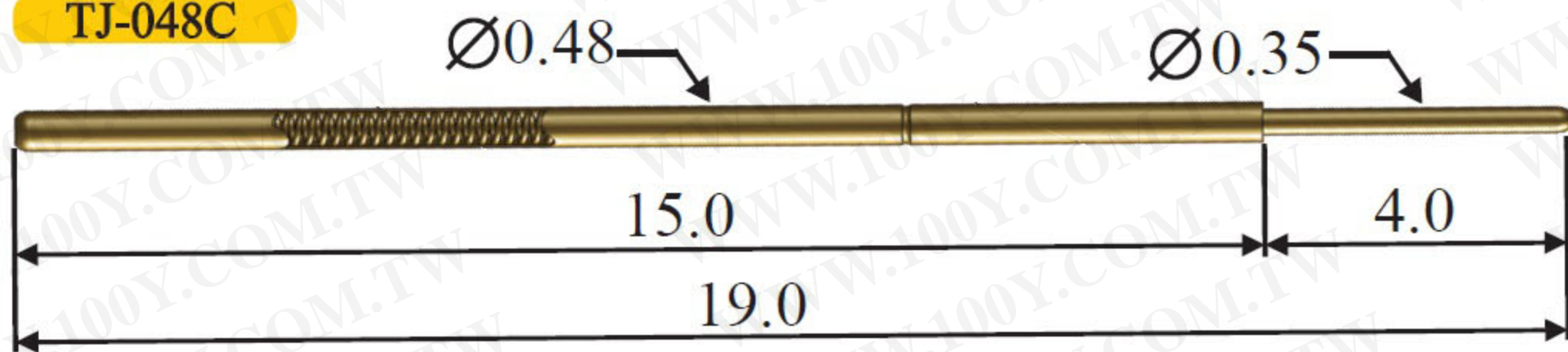

## Plunger Tips

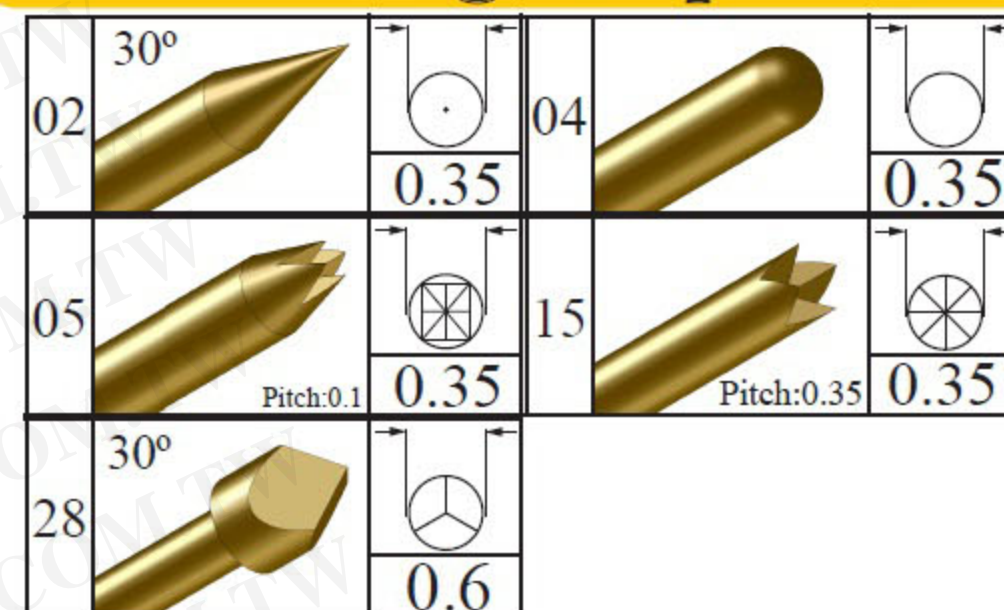

# Timejet TR-048B&C

size:0.66  
unit:mm(inch)

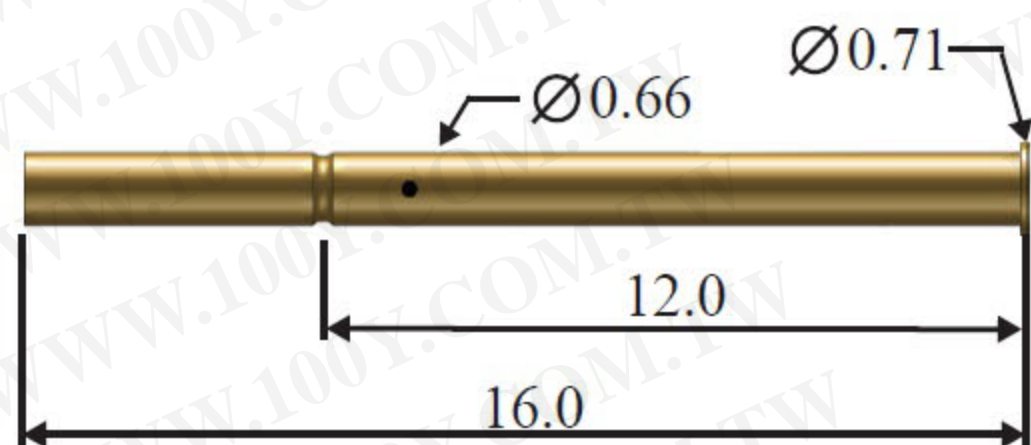

★ **TR-048BUC25C**

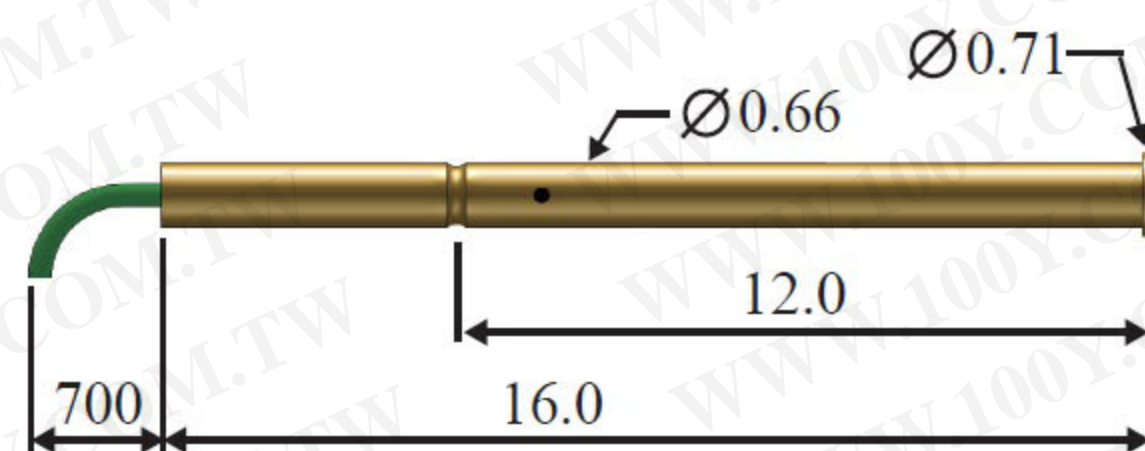

★ **TR-048BUC25W700**

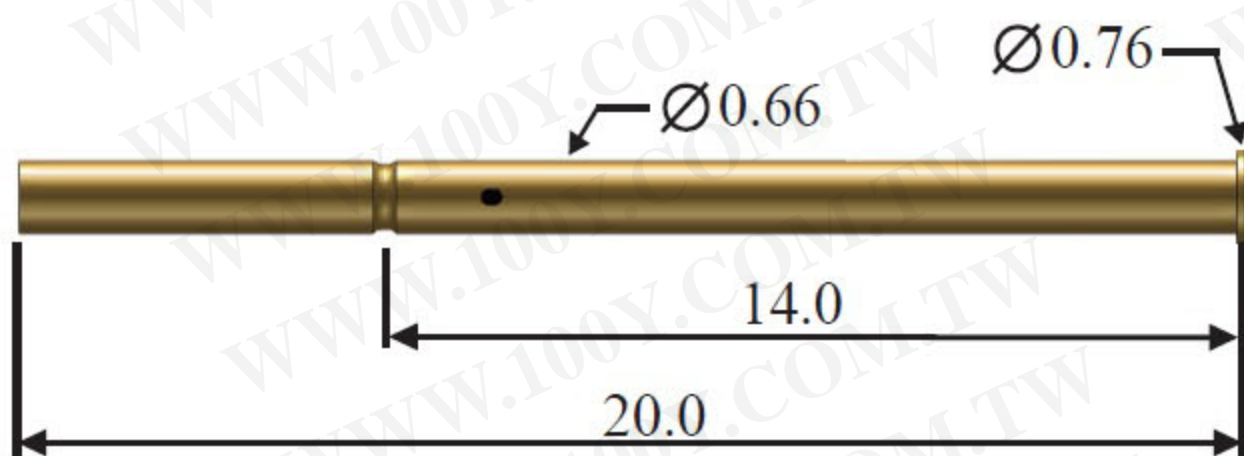

★ **TR-048CUC25C**

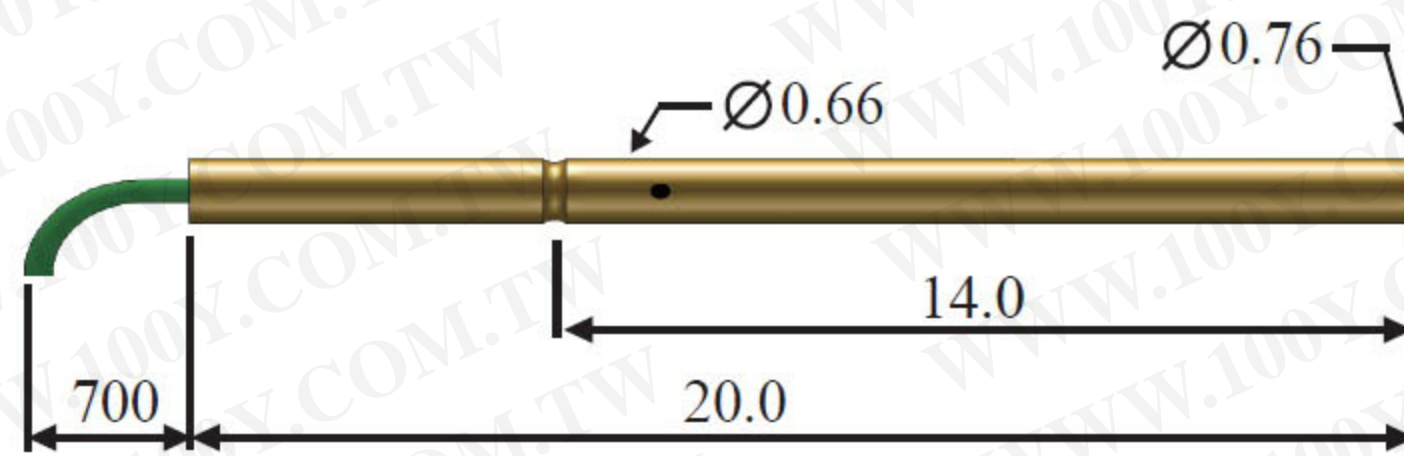

★ **TR-048CUC25W700**

## How to Order (★ Customized)

<b>TJ</b>	<b>-048</b>	<b>C</b>	<b>02</b>	<b>A</b>	<b>035</b>	<b>045</b>	<b>A</b>
Series	Size	Length	Tip	Tip Plating	Outer	Spring Force	Tube Plating
	B	C		A:Gold ★ R:Rh			A:Gold ★ N:Nickel Silver

## How to Order (★ Customized)

<b>TR</b>	<b>-048</b>	<b>C</b>	<b>UC</b>	<b>C</b>	<b>70</b>
Series	Size	Length	Style	Terminal	Wire-Length
	B	C	★ UC:V type No Rings by CNC	C:Crimp W:Wire Wrap	70:700mm

## Material Data

針軸 Plunger  
高碳鋼鍍金 SK4 with Gold Plated  
內管 Barrel  
磷青銅鍍金 Phosphor Bronze with Gold Plated  
彈簧 Spring  
琴鋼線鍍金 Music Wire with Gold Plated  
外管 Receptacle  
黃銅鍍金 Brass with Gold Plated

## Electrical Data

最小中心距 Min. Center  
0.85mm ( 0.0335" )  
建議鑽孔尺寸 Recommended Hole Size  
0.7mm ( 0.0276" )  
額定電流 Current Rating  
1A( 安培 )  
接觸電阻 Contact Resistance  
150mΩ( 毫歐姆)

## Mechanical Data

工作行程 Working Stroke  
B:1mm ( 0.0393" ) , C:3mm ( 0.1181" )  
最大行程 Maximum Stroke  
B:2mm ( 0.0787" ) , C:4mm ( 0.1574" )  
行程彈力 Spring Force at Stroke  
45g

# TJ-058A&B

size:0.58

unit:mm(inch)

# TJ serise PCB Probe

## Plunger Tips

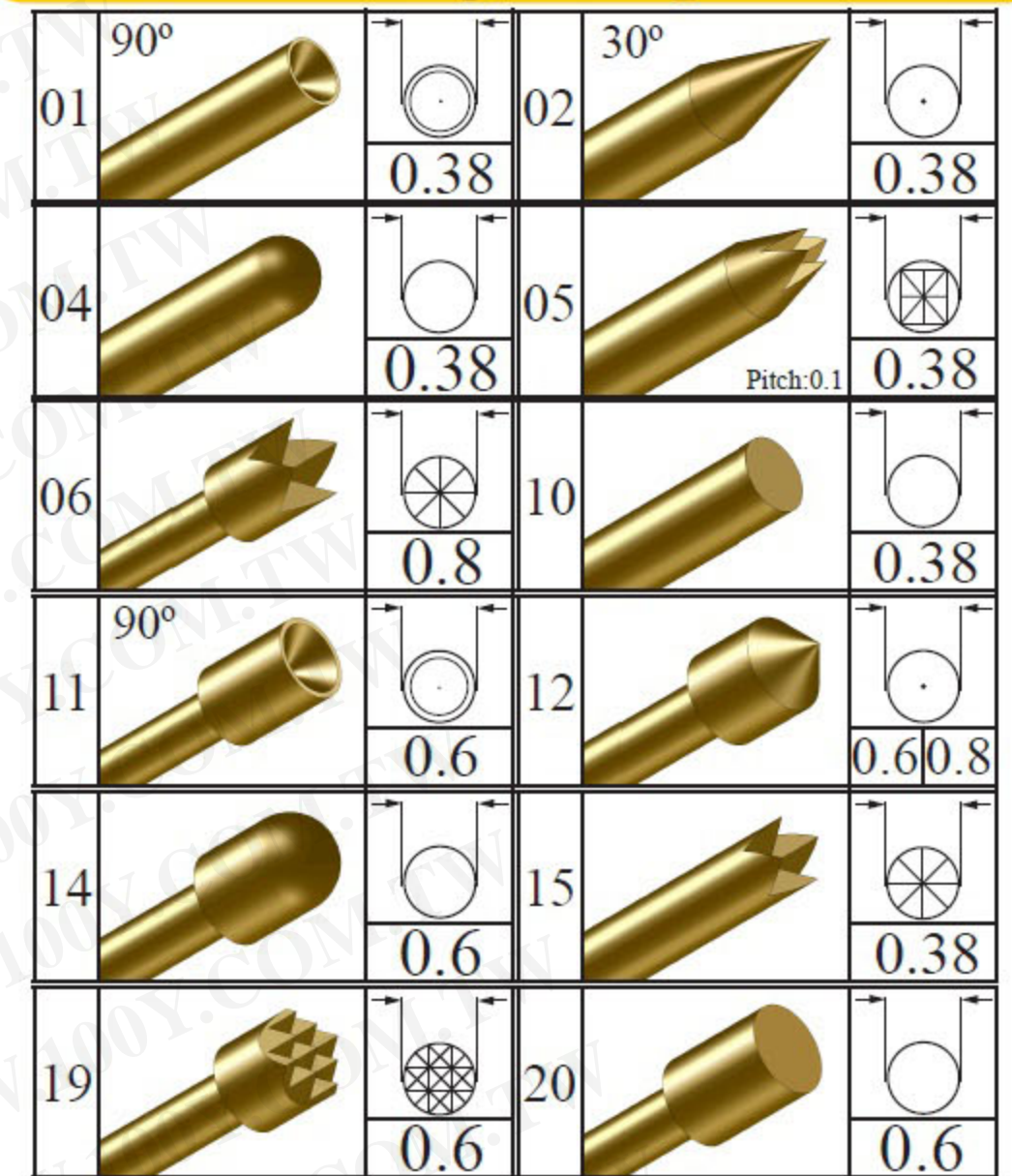

TJ-058A

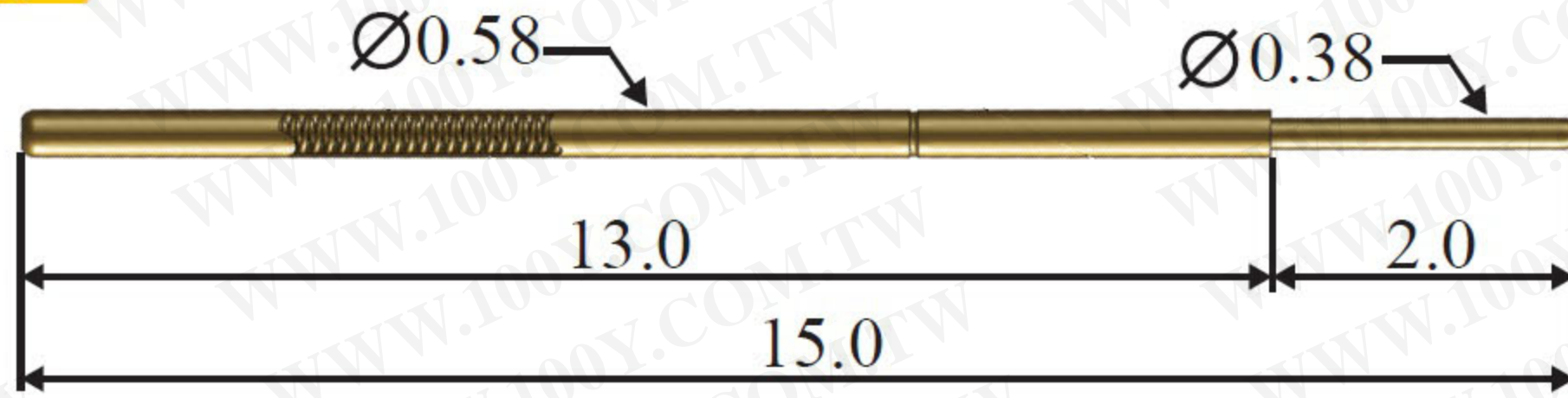

TJ-058B

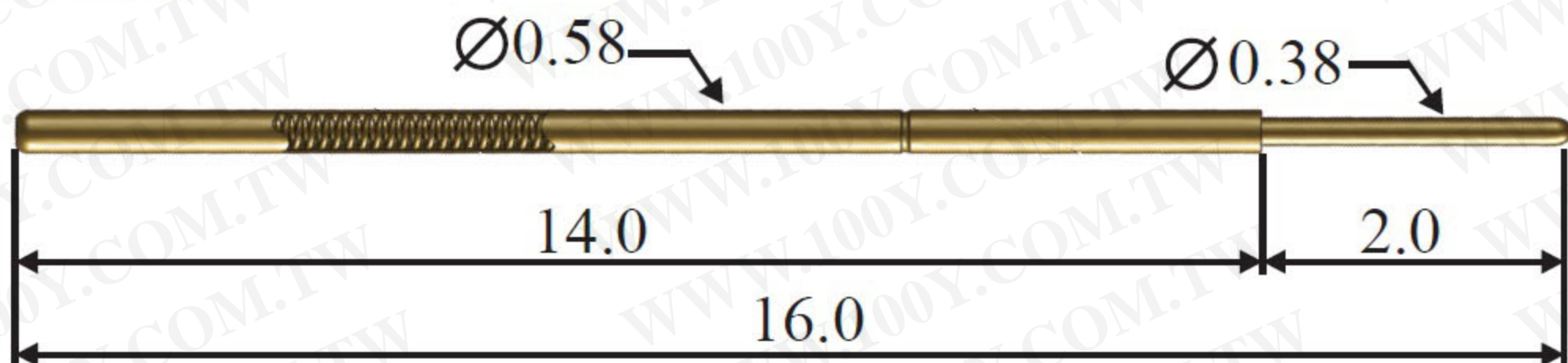

## How to Order (★ Customized)

<b>TJ</b>	<b>- 058</b>	<b>A</b>	<b>01</b>	<b>A</b>	<b>038</b>	<b>055</b>	<b>A</b>
Series	Size	Length	Tip	Tip Plating	Outer	Spring Force	Tube Plating
		A		A:Gold			A:Gold
		B		★R:Rh			★N:Nickel Silver

# Timejet TR-058A&B

size:0.72  
unit:mm(inch)

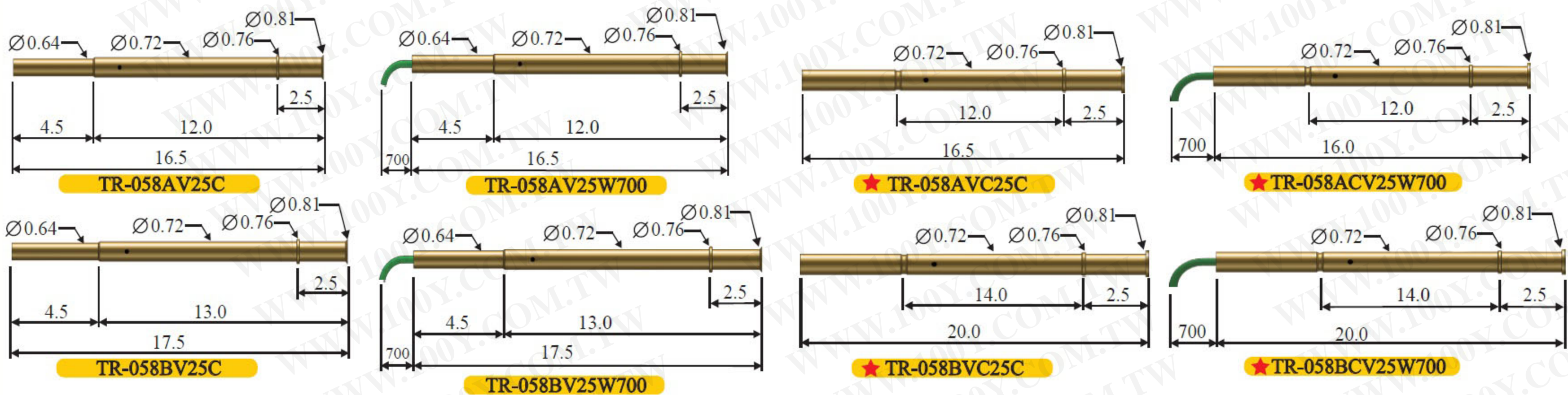

## How to Order (★ Customized)

<b>TR</b>	<b>- 058</b>	<b>A</b>	<b>V</b>	<b>25</b>	<b>C</b>	<b>70</b>
Series	Size	Length	Style	Distance of Press-Ring	Terminal	Wire-Length
		A	V:V type 1 Ring	25:2.5	C:Crimp	70:700mm
		B	★VC:V type 1 Ring by CNC		W:Wire Wrap	

### Material Data

針軸 Plunger  
高碳鋼鍍金 SK4 with Gold Plated  
內管 Barrel  
磷青銅鍍金 Phosphor Bronze with Gold Plated  
彈簧 Spring  
琴鋼線鍍金 Music Wire with Gold Plated  
外管 Receptacle  
黃銅鍍金 Brass with Gold Plated

### Electrical Data

最小中心距 Min. Center  
1.0mm ( 0.0394" )  
建議鑽孔尺寸 Recommended Hole Size  
0.75mm( 0.0296" )  
額定電流 Current Rating  
1A( 安培 )  
接觸電阻 Contact Resistance  
120mΩ( 毫歐姆)

### Mechanical Data

工作行程 Working Stroke  
1.5mm ( 0.0525" )  
最大行程 Maximum Stroke  
2mm ( 0.0787" )  
2/3 行程彈力 2/3 Spring Force at Stroke  
55g

# TJ-068A

size:0.68

unit:mm(inch)

## TJ serie PCB Probe

### Plunger Tips

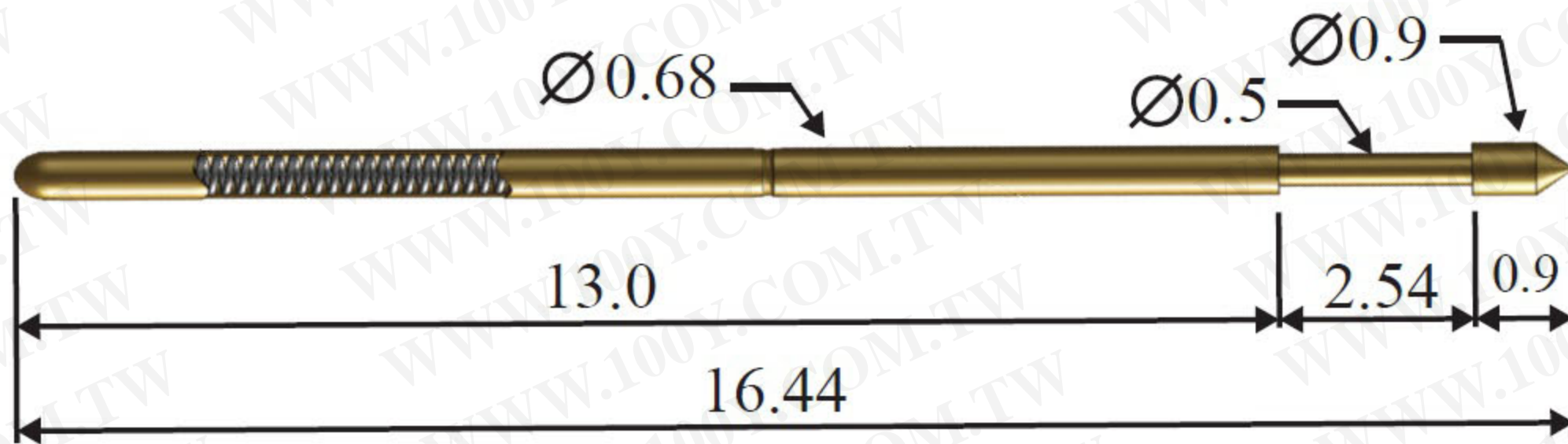

01	90°	0.5	02	30°	0.5
04		0.5	05	Pitch:0.35	0.5
★06		0.9	08		0.5
★09		0.5	10		0.5
11	90°	0.9	★12	90°	0.6 1.0 1.2
15		0.5	19		0.9
28		0.9	81		0.9
			86		0.9

### How to Order (★ Customized)

<b>TJ</b>	<b>-068</b>	<b>A</b>	<b>01</b>	<b>A</b>	<b>050</b>	<b>085</b>	<b>A</b>
Serie	Size	Length	Tip	Tip Plating	Outer	Spring Force	Tube Plating
				A:Gold ★R:Rh			A:Gold ★N:Nickel Silver

## Timejet TR-068A

size:0.86  
unit:mm(inch)

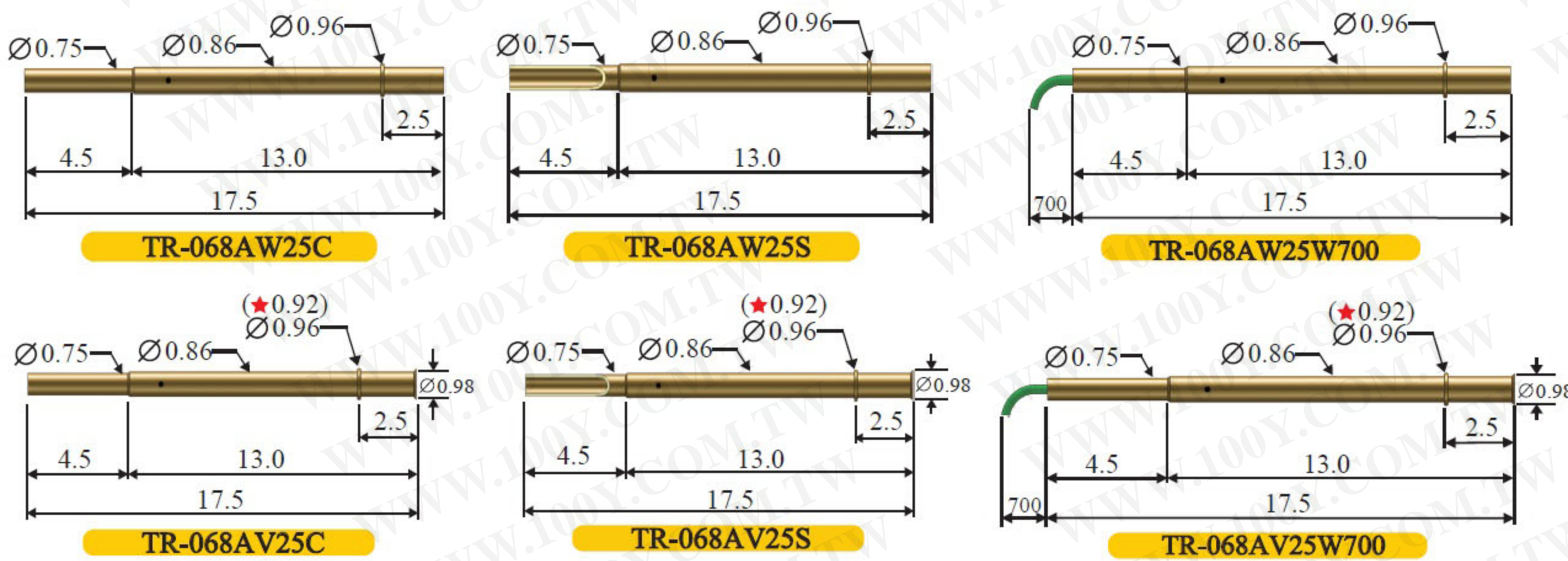

### How to Order

<b>TR</b>	<b>-068</b>	<b>A</b>	<b>W</b>	<b>25</b>	<b>C</b>	<b>70</b>	<b>28</b>
Serie	Size	Length	Style	Distance of Press-Ring	Terminal	Wire-Length	Wire-Size
			V:V type 1 Ring W: Straight type 1 Rings	25:2.5	C:Crimp S:Solder Cup W:Wire Wrap	70:700mm 90:900mm	28 30

### Material Data

針軸 Plunger  
高碳鋼鍍金 SK4 with Gold Plated  
內管 Barrel  
磷青銅鍍金 Phosphor Bronze with Gold Plated  
彈簧 Spring  
琴鋼線鍍金 Music Wire with Gold Plated  
外管 Receptacle  
黃銅鍍金 Brass with Gold Plated

### Electrical Data

最小中心距 Min. Center  
1.27mm ( 0.05" )  
建議鑽孔尺寸 Recommended Hole Size  
0.914mm~0.95mm( 0.036" ~ 0.0374" )  
額定電流 Current Rating  
1.5A( 安培 )  
接觸電阻 Contact Resistance  
70mΩ( 毫歐姆 )

### Mechanical Data

工作行程 Working Stroke  
1.7mm ( 0.0669" )  
最大行程 Maximum Stroke  
2.54mm ( 0.01" )  
工作行程彈力 Spring Force at Working Stroke  
85g

# TJ-068B

size:0.68

unit:mm(inch)

## TJ serie PCB Probe

### Plunger Tips

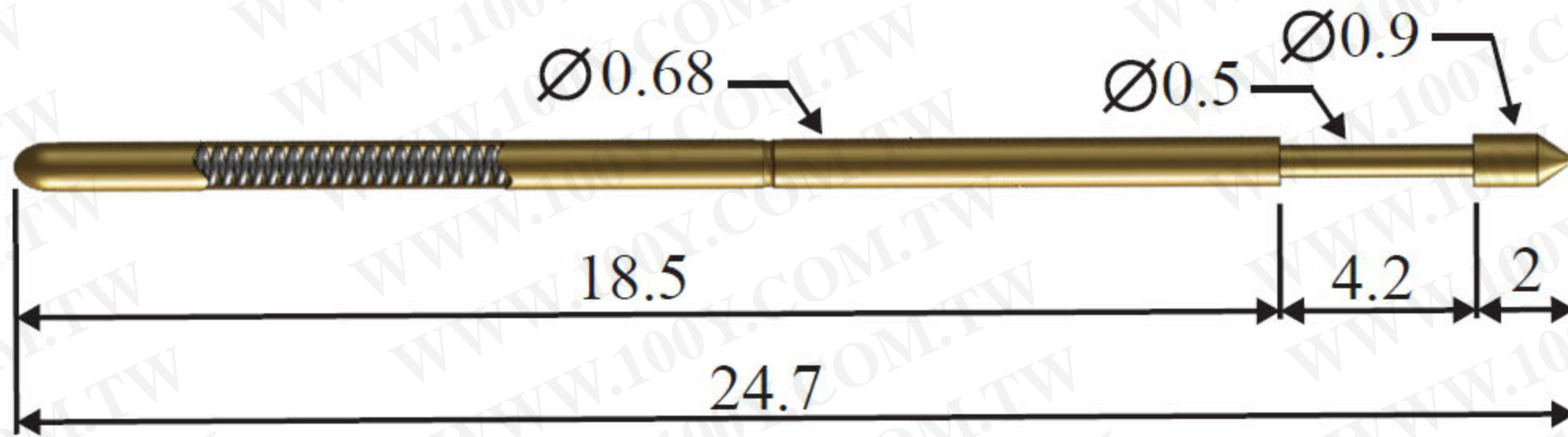

01	90°	Ø0.5	02	45°	Ø0.5
04		Ø0.5	05		Ø0.5
★06		Ø0.9	08		Ø0.5
11	90°	Ø1.0	12		Ø0.9
14		Ø0.9	15		Ø0.5
19		Ø0.9	★28		Ø1.2
81		Ø0.9			

Timejet

# TR-068B

size:0.86  
unit:mm(inch)

### How to Order (★ Customized)

**TJ - 068 B 01 A 050 085 A**  
 Serie Size Length Tip Tip Plating Outer Spring Force Tube Plating  
 A:Gold R:Rh ★N:Nickel Silver

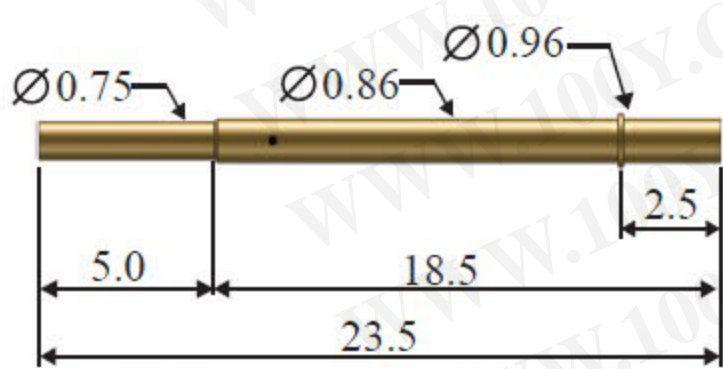

TR-068BW25C



★ TR-068BW25S

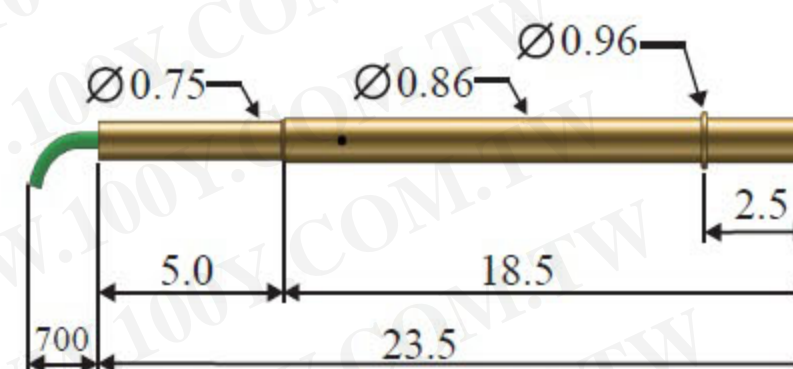

TR-068BW25W700

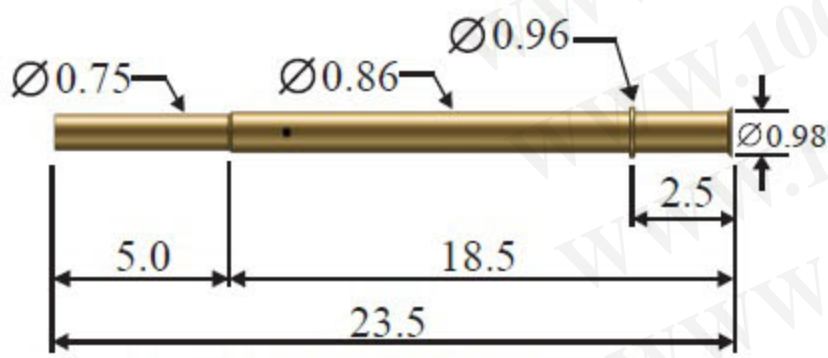

TR-068BV25C

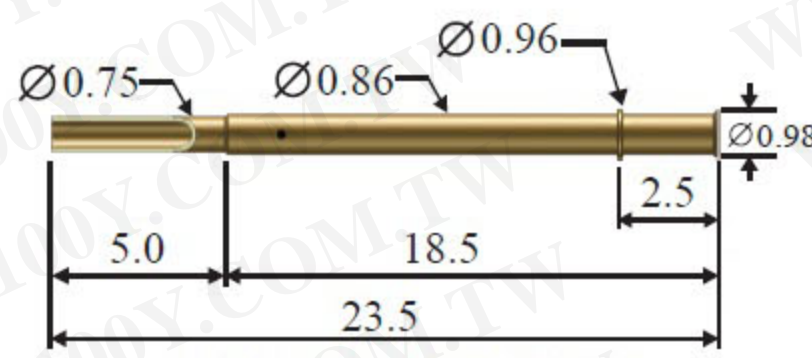

★ TR-068BV25S

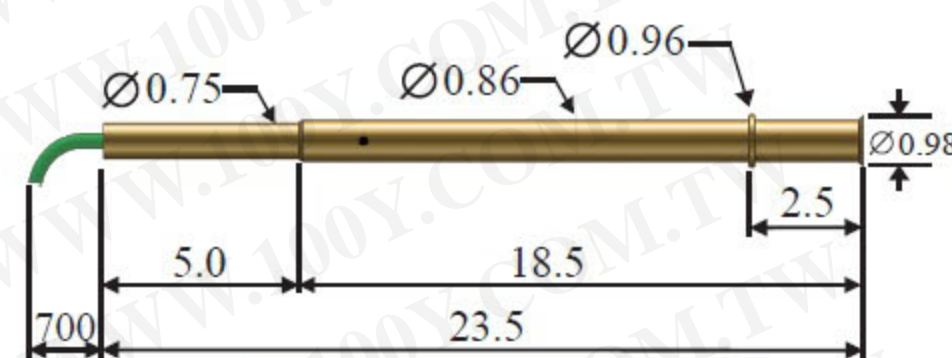

TR-068BV25W700

### How to Order (★ Customized)

**TR - 068 B W 25 C 70 28**  
 Serie Size Length Style Distance of Press-Ring Terminal Wire-Length Wire-Size  
 V:V type 1 Ring 25:2.5 C:Crimp 70:700mm 28  
 W: Straight type 1 Rings S:Solder Cup 90:900mm 30  
 W: Wire Wrap

### Material Data

針軸 Plunger  
 高碳鋼鍍金 SK4 with Gold Plated  
 內管 Barrel  
 磷青銅鍍金 Phosphor Bronze with Gold Plated  
 彈簧 Spring  
 琴鋼線鍍金 Music Wire with Gold Plated  
 外管 Receptacle  
 黃銅鍍金 Brass with Gold Plated

### Electrical Data

最小中心距 Min. Center  
 1.27mm (0.05")  
 建議鑽孔尺寸 Recommended Hole Size  
 0.95mm(0.0374")  
 額定電流 Current Rating  
 3A( 安培 )  
 接觸電阻 Contact Resistance  
 30mΩ( 毫歐姆 )

### Mechanical Data

工作行程 Working Stroke  
 1.7mm (0.0669")  
 最大行程 Maximum Stroke  
 4.2mm (0.1653")  
 工作行程彈力 Spring Force at Working Stroke  
 85g

# TJ-101A

size:1.01

unit:mm(inch)

## TJ serie PCB Probe

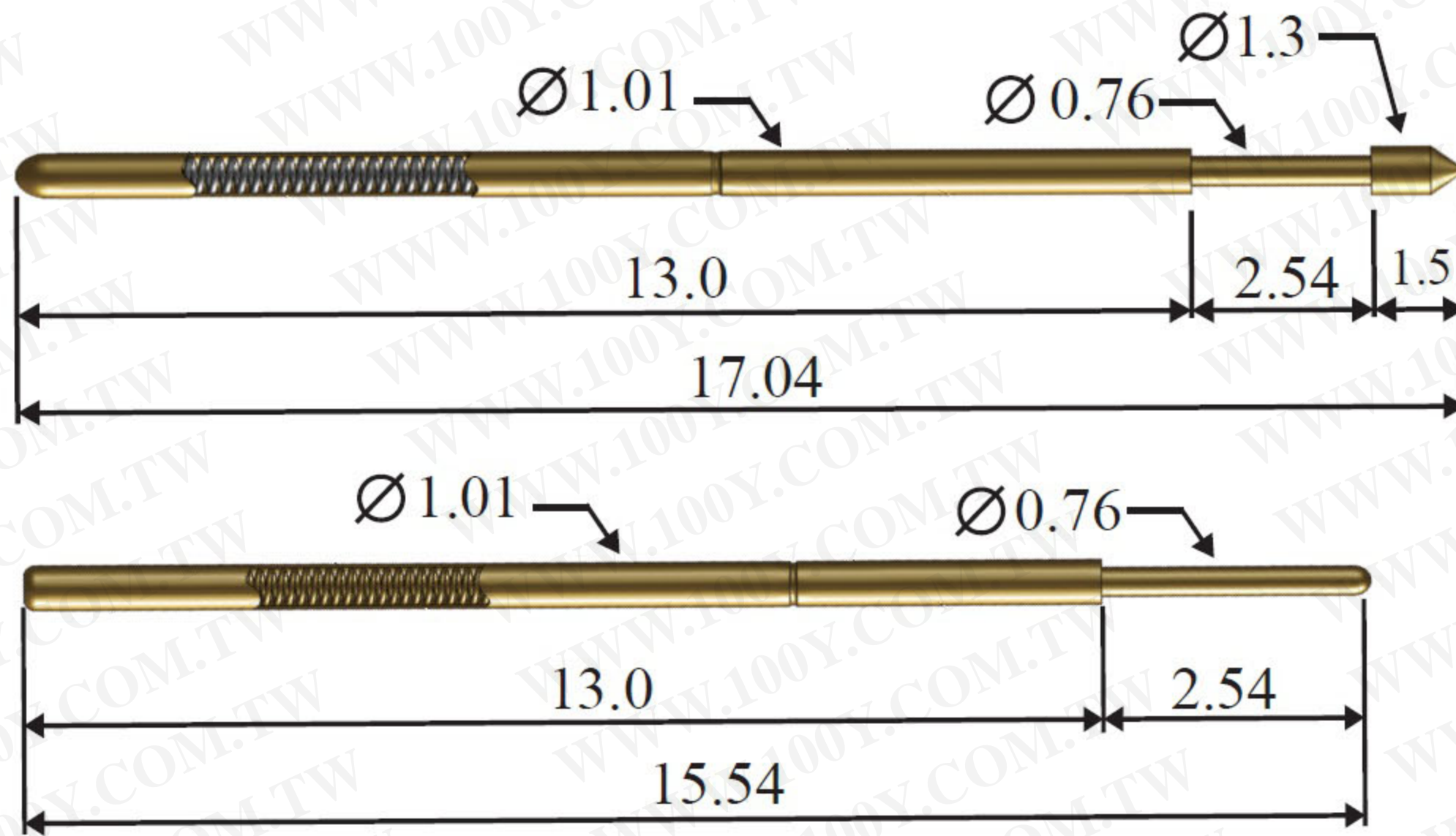

### Plunger Tips

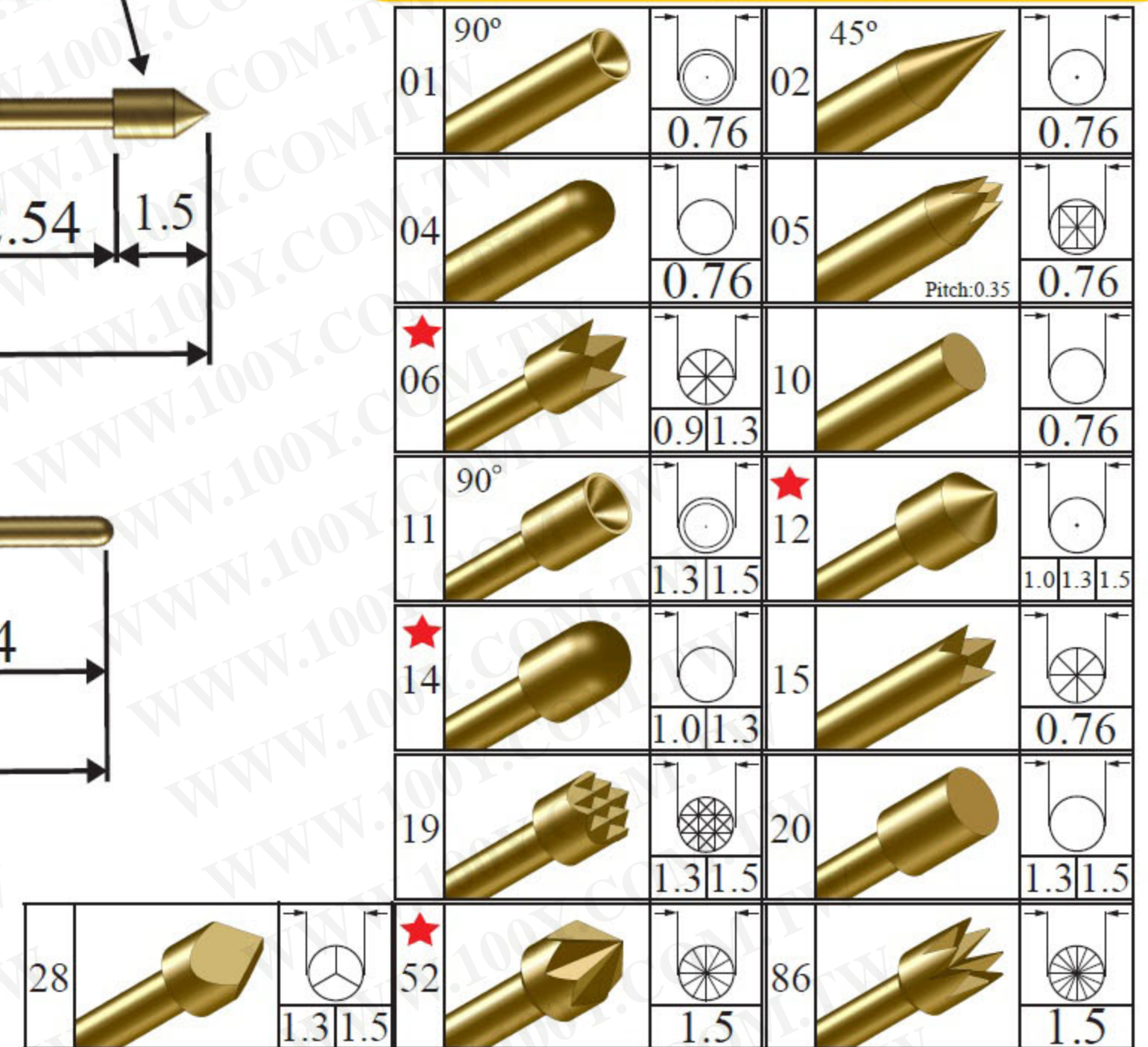

### How to Order (★ Customized)

<b>TJ</b>	<b>-101</b>	<b>A</b>	<b>01</b>	<b>A</b>	<b>076</b>	<b>085</b>	<b>A</b>
Series	Size	Length	Tip	Tip Plating	Outer	Spring Force	Tube Plating
				A:Gold ★R:Rh			A:Gold ★N:Nickel Silver

## Timejet TR-101A

size:1.31  
unit:mm(inch)

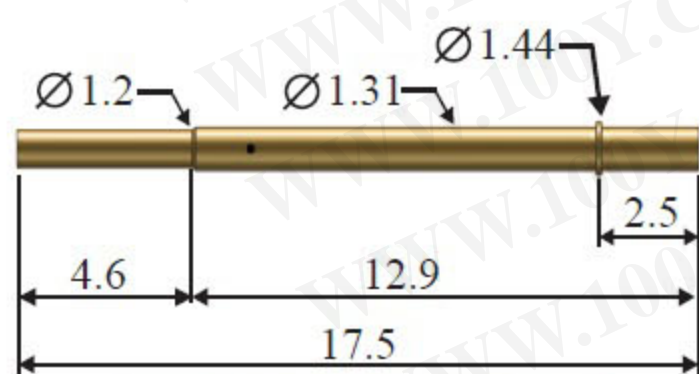

TR-101AW25C

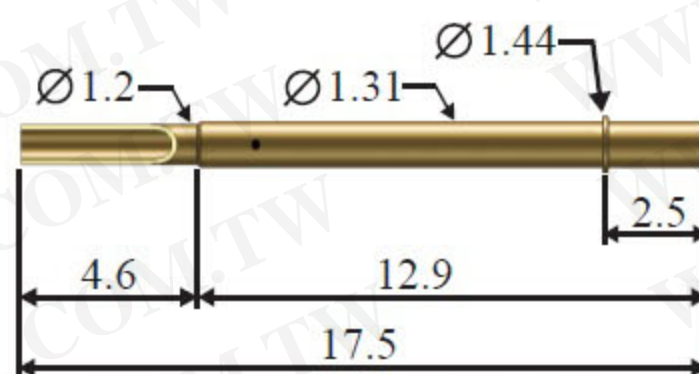

★ TR-101AW25S

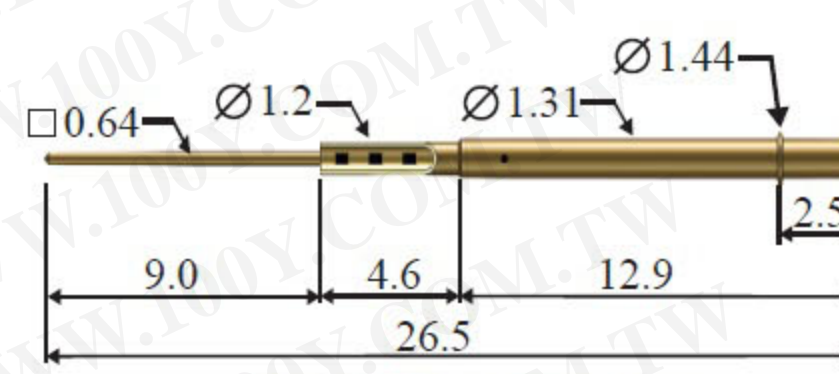

TR-101AW25W90

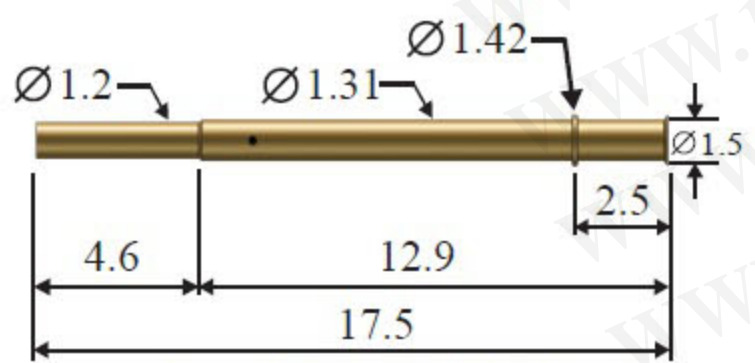

TR-101AV25C

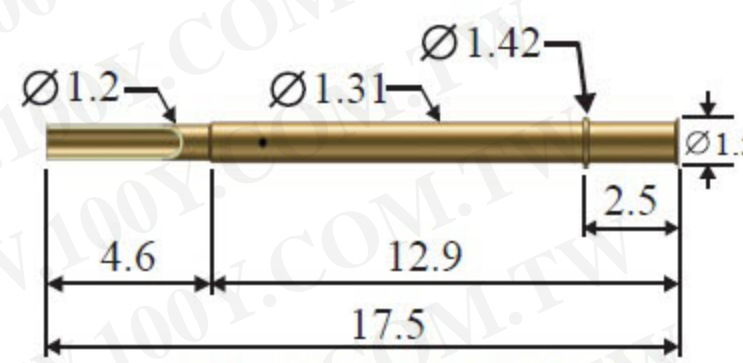

★ TR-101AV25S

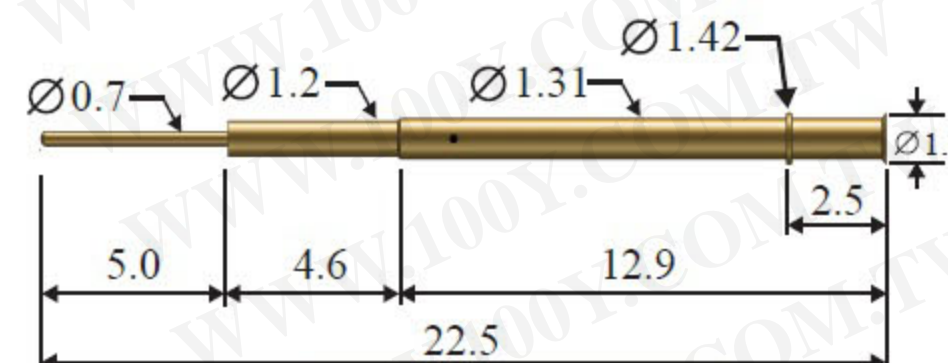

TR-101AV25T05



TR-101AV25W09

### How to Order (★ Customized)

<b>TR</b>	<b>-101</b>	<b>A</b>	<b>W</b>	<b>25</b>	<b>C</b>	<b>05</b>
Series	Size	Length	Style	Distance of Press-Ring	Terminal	Pin-Length
			V:V type 1 Ring W: Straight type 1 Rings	25:2.5	C:Crimp S:Solder Cup W: Square Pin T: Circular Pin	46:4.6mm 05:5mm 09:9mm

### Material Data

針軸 Plunger  
高碳鋼鍍金 SK4 with Gold Plated  
內管 Barrel  
磷青銅鍍金 Phosphor Bronze with Gold Plated  
彈簧 Spring  
琴鋼線鍍金 Music Wire with Gold Plated  
外管 Receptacle  
黃銅鍍金 Brass with Gold Plated

### Electrical Data

最小中心距 Min. Center  
1.9mm ( 0.0748" )  
建議鑽孔尺寸 Recommended Hole Size  
1.35mm~1.4mm( 0.0531" ~ 0.0551" )  
額定電流 Current Rating  
3A( 安培 )  
接觸電阻 Contact Resistance  
50mΩ( 毫歐姆 )

### Mechanical Data

工作行程 Working Stroke  
1.7mm ( 0.0669" )  
最大行程 Maximum Stroke  
2.54mm ( 0.1" )  
工作行程彈力 Spring Force at Working Stroke  
85g

# TJ-101B

size:1.01

unit:mm(inch)

## TJ serie PCB Probe

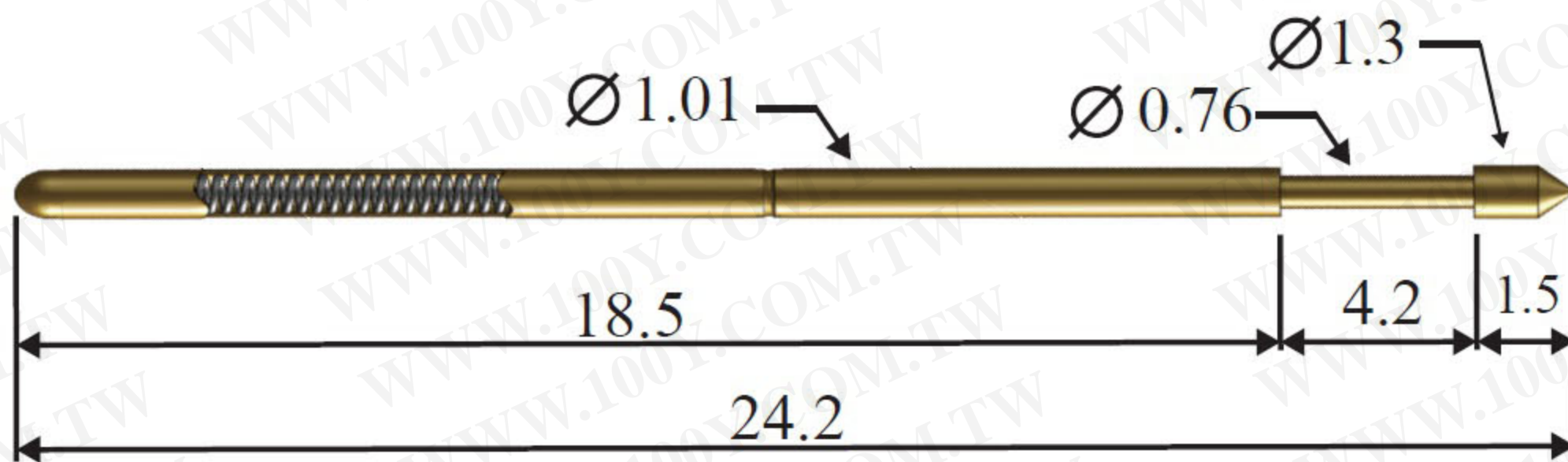

### Plunger Tips

01	90°	Ø0.76	02	45°	Ø0.76
04		Ø0.76	05	Pitch:0.35	Ø0.76
10		Ø0.76	11	90°	1.5
12	90°	1.3 1.5	14		1.0 1.3
15		Ø0.76	19		1.3 1.5
20		1.3 1.5	28	30°	1.5
★52		1.5	81		1.2

## Timejet TR-101B

size:1.31  
unit:mm(inch)

### How to Order (★ Customized)

<b>TJ</b>	<b>-101</b>	<b>B</b>	<b>01</b>	<b>A</b>	<b>076</b>	<b>100</b>	<b>A</b>
Serie	Size	Length	Tip	Tip Plating	Outer	Spring Force	Tube Plating
				A:Gold ★R:Rh		100:100g	A:Gold N:Nickel Silver

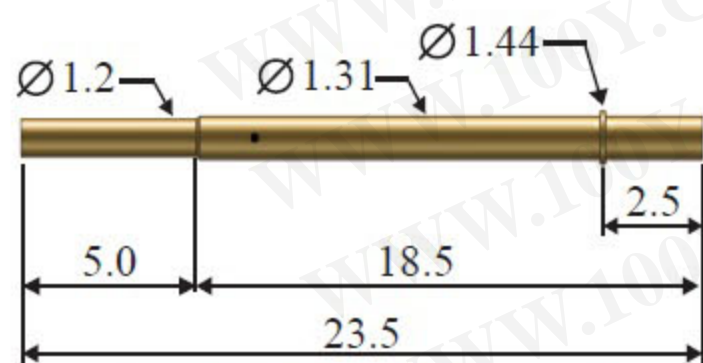

TR-101BW25C

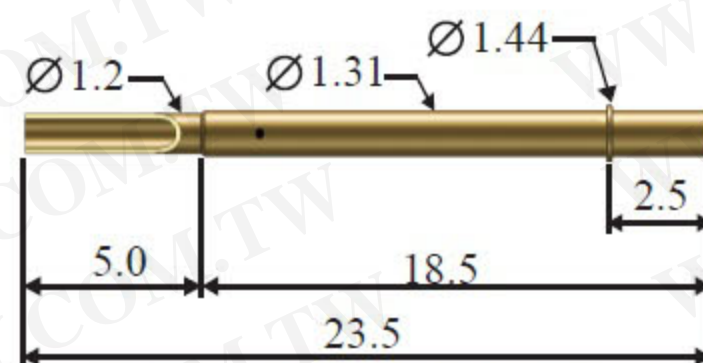

TR-101BW25S

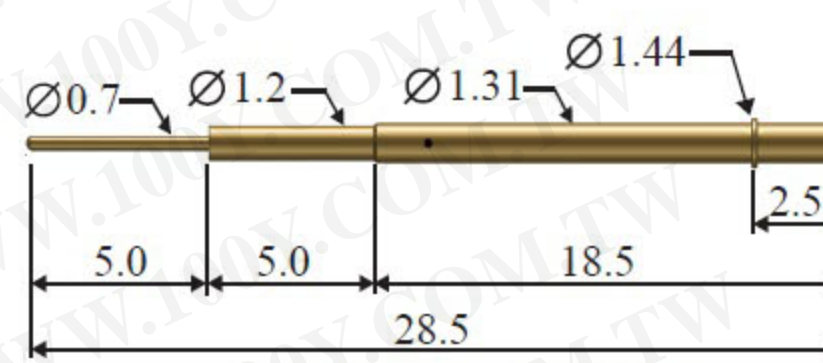

TR-101BW25T05

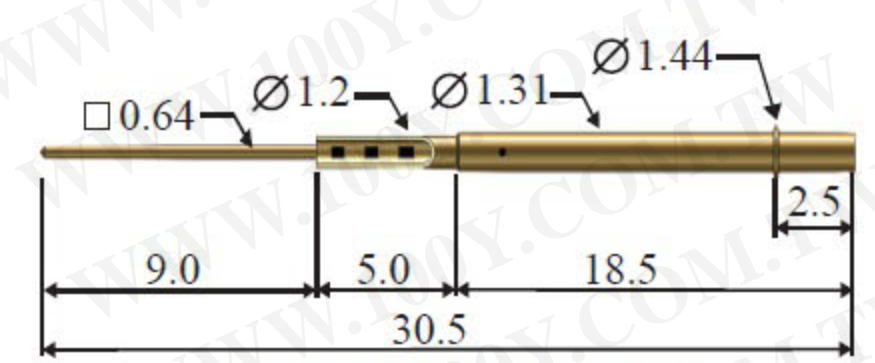

TR-101BW25W09

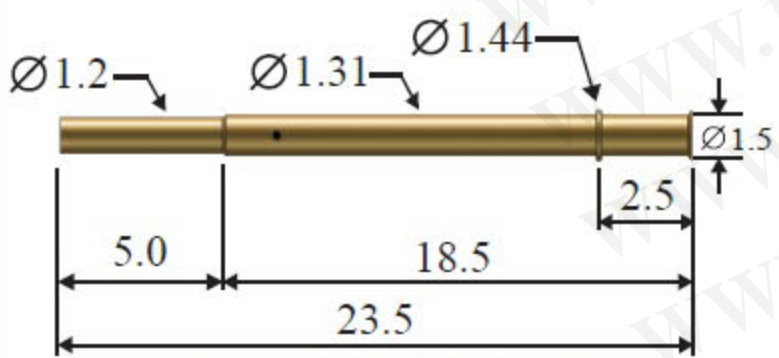

TR-101BV25C

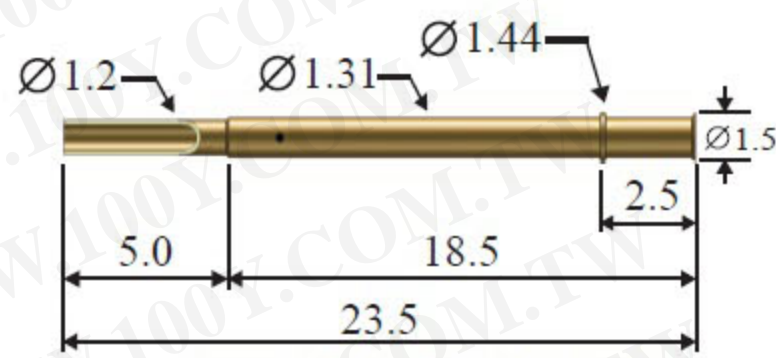

TR-101BV25S

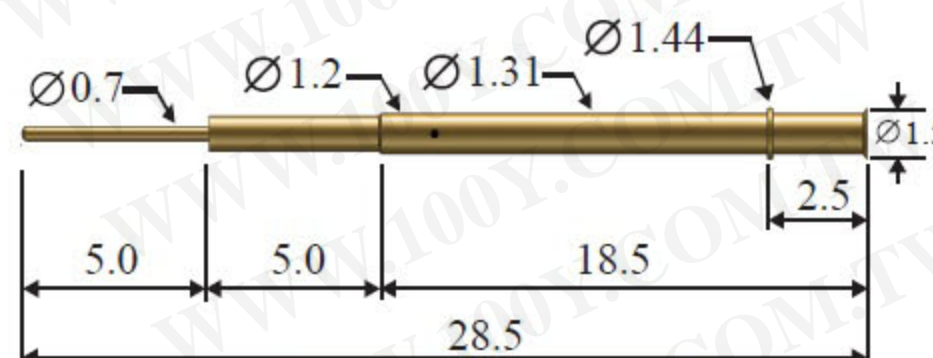

TR-101BV25T05



TR-101BV25W09

### How to Order

<b>TR</b>	<b>-101</b>	<b>B</b>	<b>W</b>	<b>25</b>	<b>C</b>	<b>05</b>
Serie	Size	Length	Style	Distance of Press-Ring	Terminal	Pin-Length
			V:V type 1 Ring W: Straight type 1 Rings	25:2.5	C:Crimp S:Solder Cup W:Square Pin T:Circular Pin	05:5mm 09:9mm

### Material Data

針軸 Plunger  
高碳鋼鍍金 SK4 with Gold Plated  
內管 Barrel  
磷青銅鍍金 Phosphor Bronze with Gold Plated  
彈簧 Spring  
琴鋼線鍍金 Music Wire with Gold Plated  
外管 Receptacle  
黃銅鍍金 Brass with Gold Plated

### Electrical Data

最小中心距 Min. Center  
1.9mm ( 0.0749" )  
建議鑽孔尺寸 Recommended Hole Size  
1.35mm~1.4mm( 0.0531" ~ 0.0551" )  
額定電流 Current Rating  
3A( 安培 )  
接觸電阻 Contact Resistance  
50mΩ( 毫歐姆 )

### Mechanical Data

工作行程 Working Stroke  
2.8mm ( 0.1102" )  
最大行程 Maximum Stroke  
4.2mm ( 0.1653" )  
工作行程彈力 Spring Force at Working Stroke  
100g

# TJ-101C

size:1.01

unit:mm(inch)

# TJ serie PCB Probe

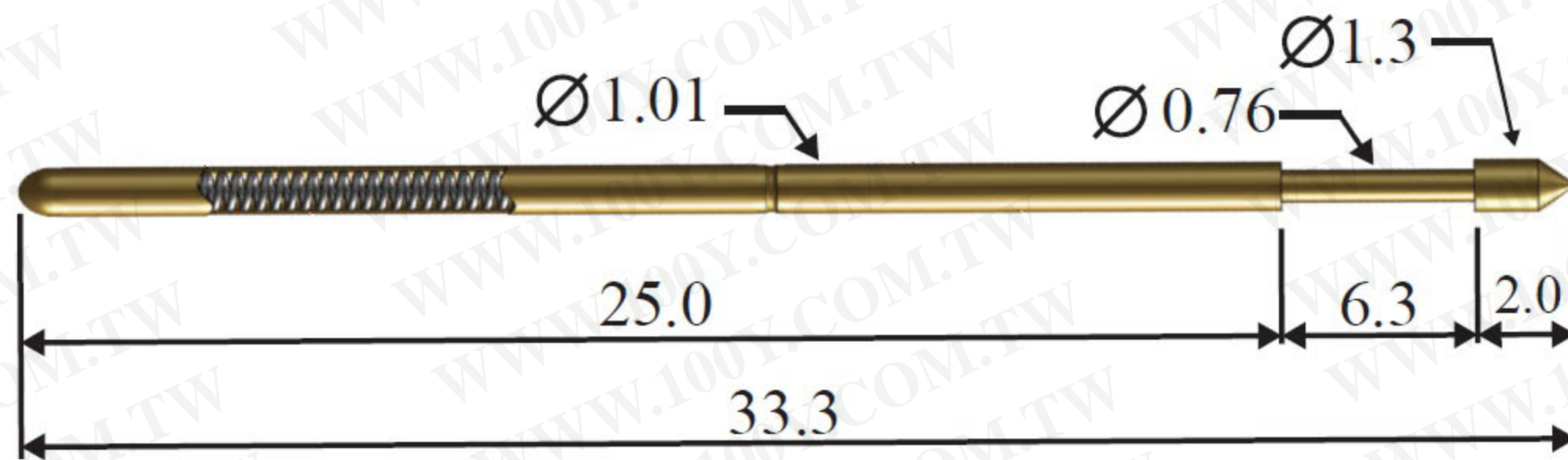

## Plunger Tips

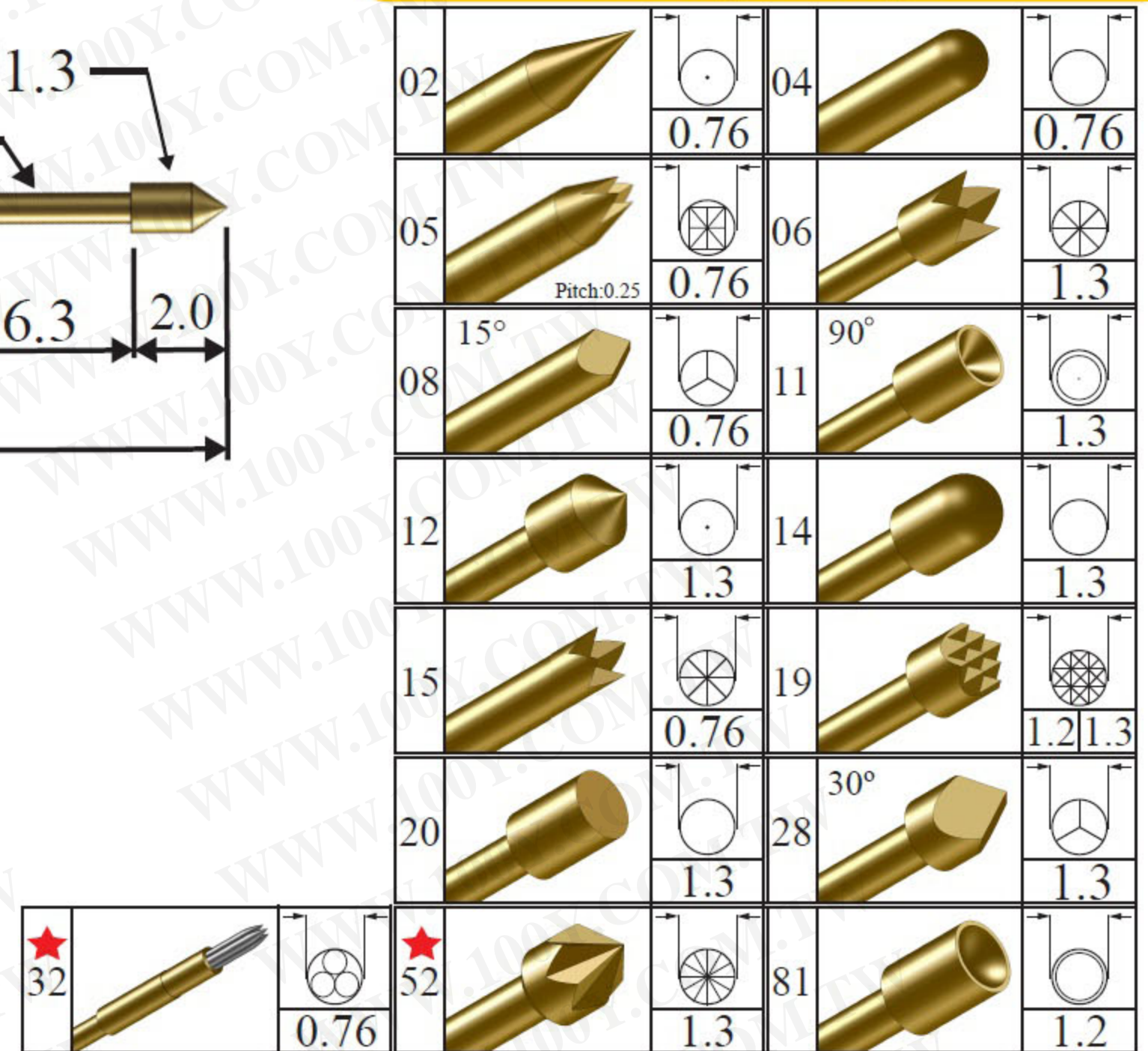

# Timejet TR-101C

size:1.31  
unit:mm(inch)

## How to Order (★ Customized)

<b>TJ</b>	<b>-101</b>	<b>C</b>	<b>02</b>	<b>A</b>	<b>076</b>	<b>100</b>	<b>A</b>
Series	Size	Length	Tip	Tip Plating	Outer	Spring Force	Tube Plating
				A:Gold R:Rh		100:100g 200:200g 300:300g	A:Gold ★N:Nickel Silver

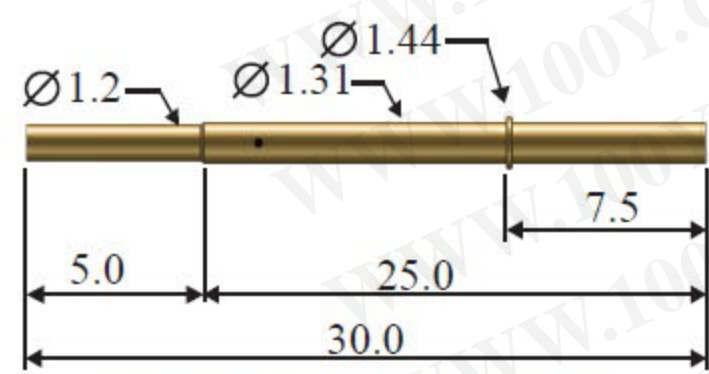

TR-101CW75C

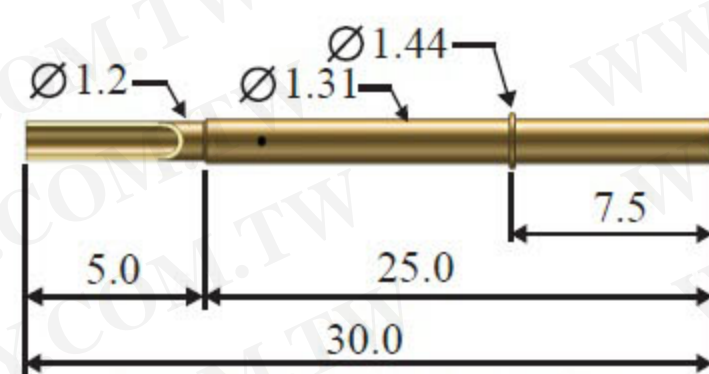

TR-101CW75S

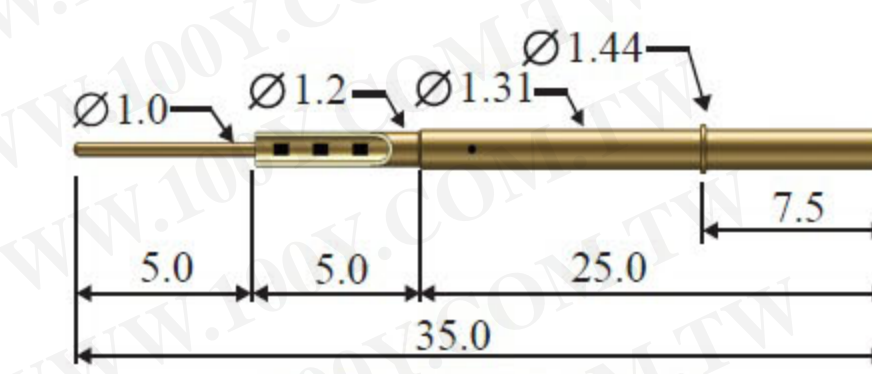

TR-101CW75T05

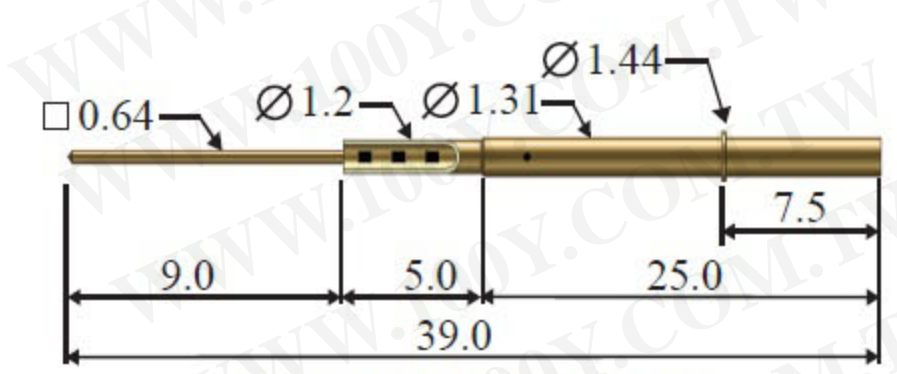

CR-101CW75(W)09

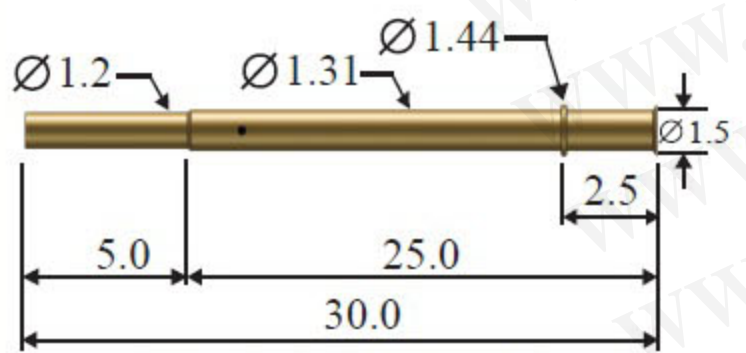

TR-101CV25C

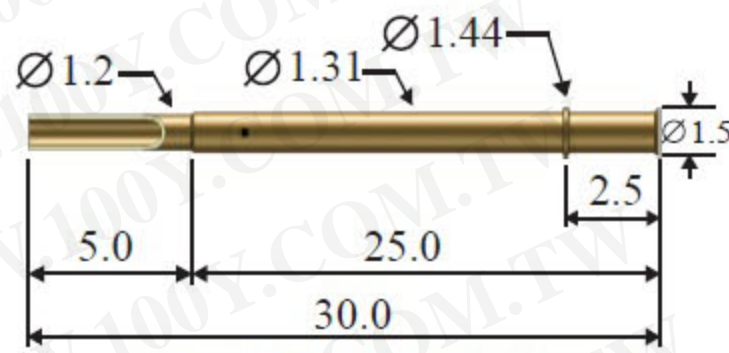

TR-101CV25S



TR-101CV25T05

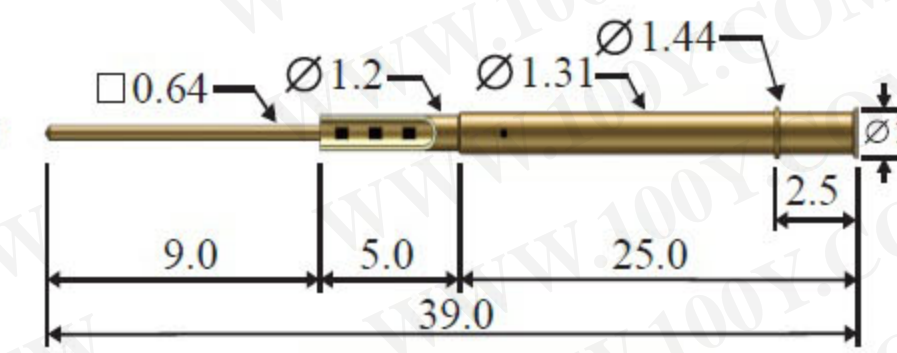

TR-101CV25(W)09

## How to Order (★ Customized)

<b>TR</b>	<b>-101</b>	<b>C</b>	<b>W</b>	<b>75</b>	<b>C</b>	<b>05</b>
Series	Size	Length	Style	Distance of Press-Ring	Terminal	Pin-Length
			V:V type 1 Ring W: Straight type 1 Rings	25:2.5 75:7.5	C:Crimp S:Solder Cup W: Square Pin T: Circular Pin	05:5mm 09:9mm

## Material Data

針軸 Plunger  
高碳鋼鍍金 SK4 with Gold Plated  
內管 Barrel  
磷青銅鍍金 Phosphor Bronze with Gold Plated  
彈簧 Spring  
琴鋼線鍍金 Music Wire with Gold Plated  
外管 Receptacle  
黃銅鍍金 Brass with Gold Plated

## Electrical Data

最小中心距 Min. Center  
1.9mm (0.0749")  
建議鑽孔尺寸 Recommended Hole Size  
1.35mm~1.4mm (0.0531" ~ 0.0551")  
額定電流 Current Rating  
3A (安培)  
接觸電阻 Contact Resistance  
50mΩ (毫歐姆)

## Mechanical Data

工作行程 Working Stroke  
4.2mm (0.1655")  
最大行程 Maximum Stroke  
6.3mm (0.2480")  
工作行程彈力 Spring Force at Working Stroke  
100g, 200g, 300g

# TJ-136A

size:1.36

unit:mm(inch)

## TJ serie PCB Probe

### Plunger Tips

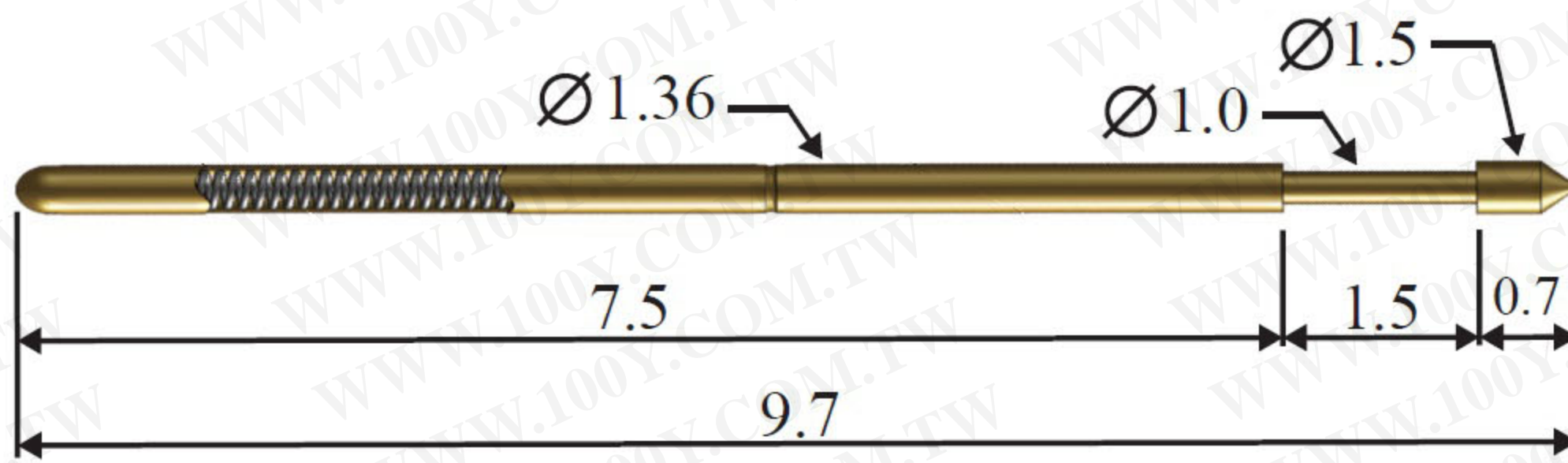

## Timejet TR-136A

size:1.66  
unit:mm(inch)

### How to Order (★ Customized)

<b>TJ</b>	<b>-136</b>	<b>A</b>	<b>02</b>	<b>A</b>	<b>100</b>	<b>055</b>	<b>A</b>
Series	Size	Length	Tip	Tip Plating	Outer	Spring Force	Tube Plating
				A:Gold ★R:Rh			A:Gold N:Nickel Silver

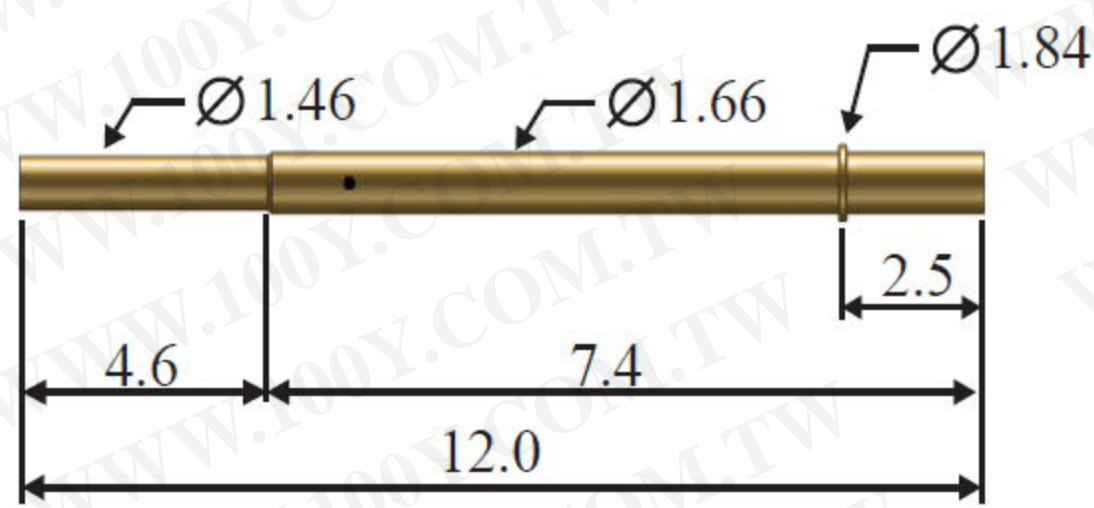

TR-136AW25C

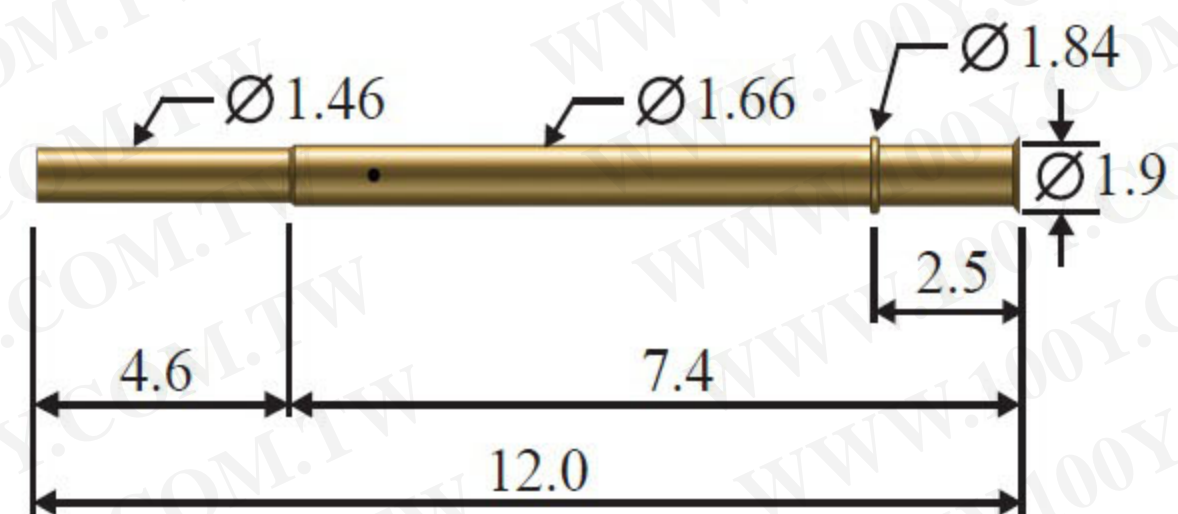

TR-136AV25C

### How to Order (★ Customized)

<b>TR</b>	<b>-136</b>	<b>A</b>	<b>W</b>	<b>25</b>	<b>C</b>
Series	Size	Length	Style	Distance of Press-Ring	Terminal
			V:V type 1 Ring W: Straight type 1 Rings	25:2.5	C:Crimp

### Material Data

針軸 Plunger  
高碳鋼鍍金 SK4 with Gold Plated  
內管 Barrel  
磷青銅鍍金 Phosphor Bronze with Gold Plated  
彈簧 Spring  
琴鋼線鍍金 Music Wire with Gold Plated  
外管 Receptacle  
黃銅鍍金 Brass with Gold Plated

### Electrical Data

最小中心距 Min. Center  
2.54mm ( 0.100" )  
建議鑽孔尺寸 Recommended Hole Size  
1.7mm~1.75mm( 0.0669" ~ 0.0689" )  
額定電流 Current Rating  
3A( 安培 )  
接觸電阻 Contact Resistance  
30mΩ( 毫歐姆)

### Mechanical Data

工作行程 Working Stroke  
1.0mm ( 0.0393" )  
最大行程 Maximum Stroke  
1.5mm ( 0.0590" )  
工作行程彈力 Spring Force at Working Stroke  
55g

# TJ-136B

size:1.36

unit:mm(inch)

## TJ serie PCB Probe

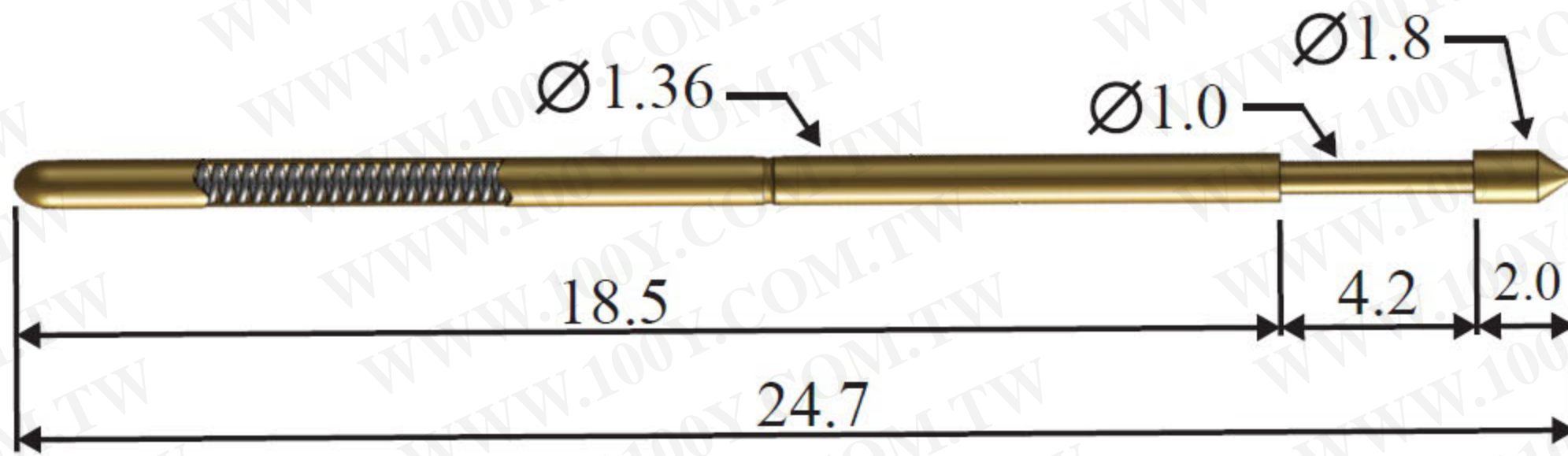

### Plunger Tips

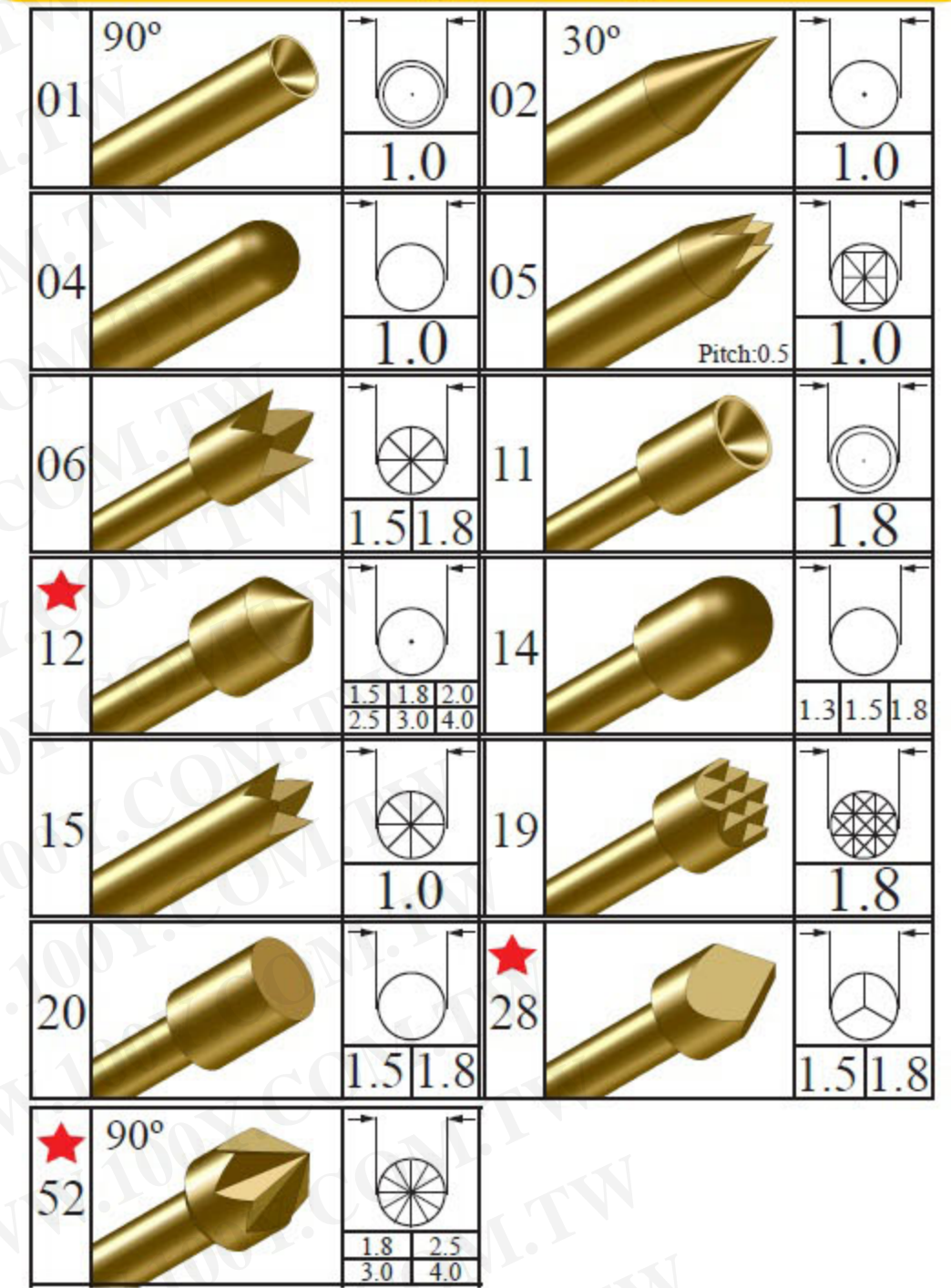

### How to Order (★ Customized)

<b>TJ</b>	<b>-136</b>	<b>B</b>	<b>02</b>	<b>A</b>	<b>100</b>	<b>100</b>	<b>A</b>
Serie	Size	Length	Tip	Tip Plating	Outer	Spring Force	Tube Plating
				A:Gold ★R:Rh		100:100g 200:200g	A:Gold N:Nickel Silver

## Timejet TR-136B

size:1.66  
unit:mm(inch)

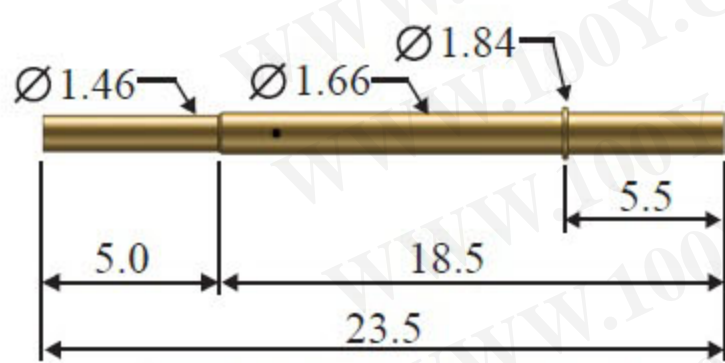

TR-136BW55C



TR-136BW55S

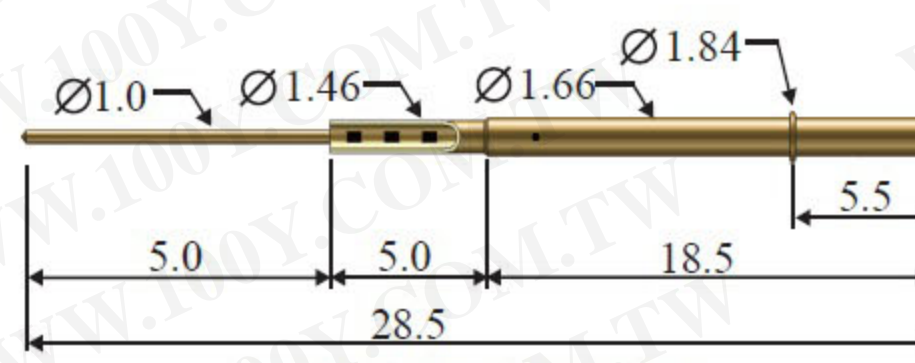

TR-136BW55T05

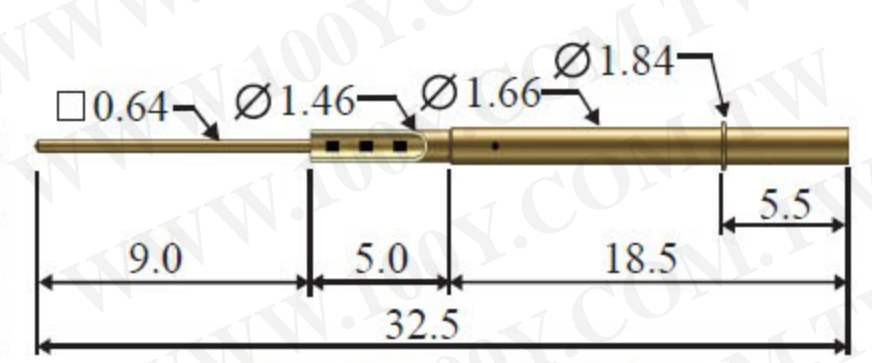

TR-136BW25(W)09

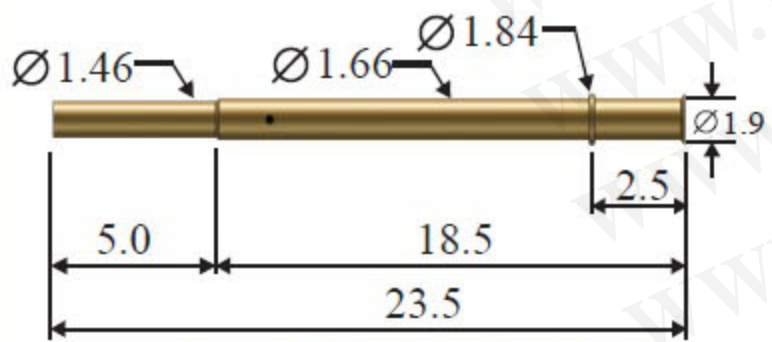

TR-136BV25C

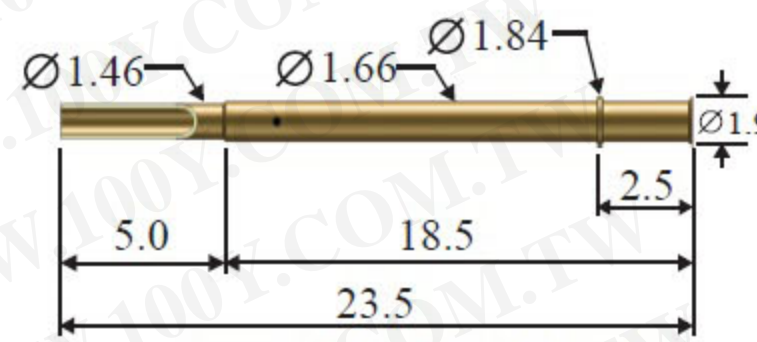

TR-136BV25S

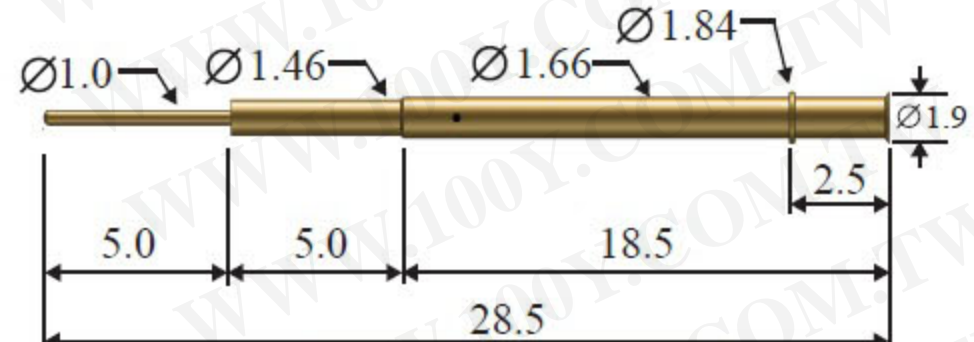

TR-136BV25T05

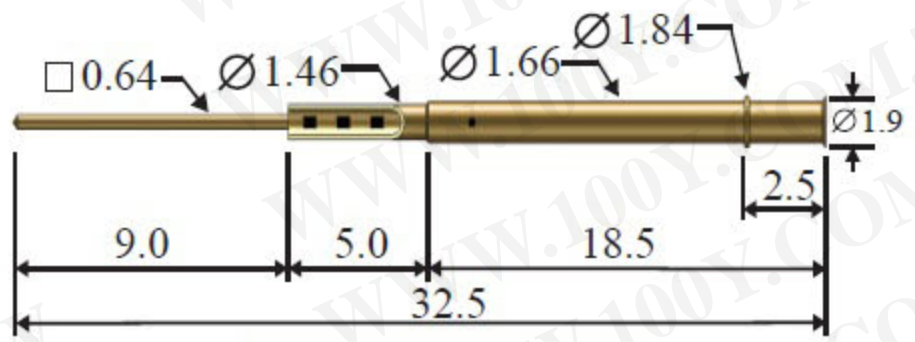

TR-136BV25(W)09

### How to Order

<b>TR</b>	<b>-136</b>	<b>B</b>	<b>W</b>	<b>25</b>	<b>C</b>	<b>05</b>
Serie	Size	Length	Style	Distance of Press-Ring	Terminal	Pin-Length
			V:V type 1 Ring W: Straight type 1 Rings	25:2.5 55:5.5	C:Crimp S:Solder Cup W:Square Pin T:Circular Pin	05:5mm 09:9mm

### Material Data

針軸 Plunger  
高碳鋼鍍金 SK4 with Gold Plated  
內管 Barrel  
磷青銅鍍金 Phosphor Bronze with Gold Plated  
彈簧 Spring  
琴鋼線鍍金 Music Wire with Gold Plated  
外管 Receptacle  
黃銅鍍金 Brass with Gold Plated

### Electrical Data

最小中心距 Min. Center  
2.54mm ( 0.100" )  
建議鑽孔尺寸 Recommended Hole Size  
1.7mm~1.75mm( 0.0669" ~ 0.0689" )  
額定電流 Current Rating  
3A( 安培 )  
接觸電阻 Contact Resistance  
30mΩ( 毫歐姆 )

### Mechanical Data

工作行程 Working Stroke  
3mm ( 0.1181" )  
最大行程 Maximum Stroke  
4.2mm ( 0.1653" )  
行程彈力 Spring Force at Working Stroke  
100g,200g

# TJ-136C

size:1.36

unit:mm(inch)

# TJ serie PCB Probe

## Plunger Tips

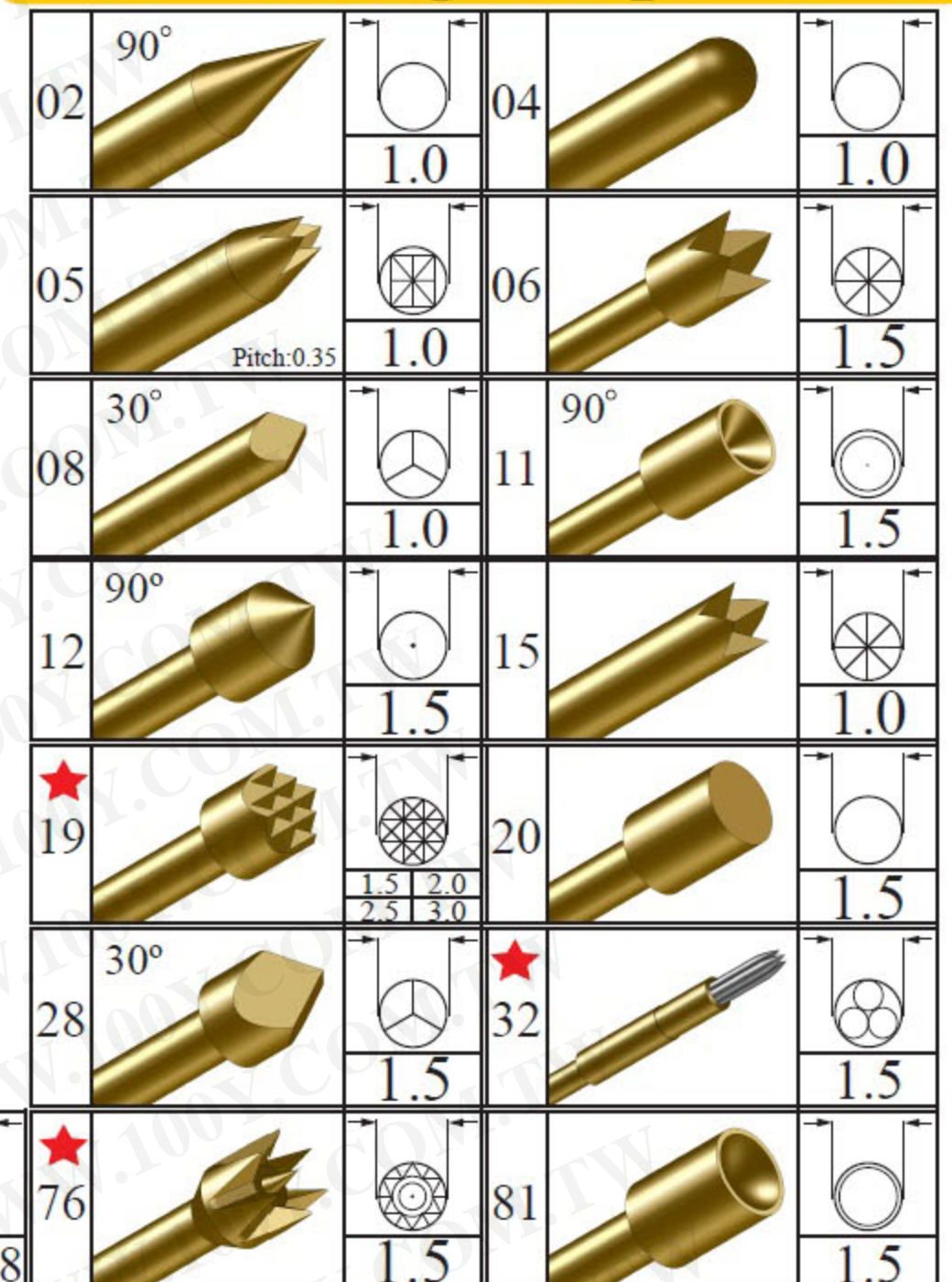
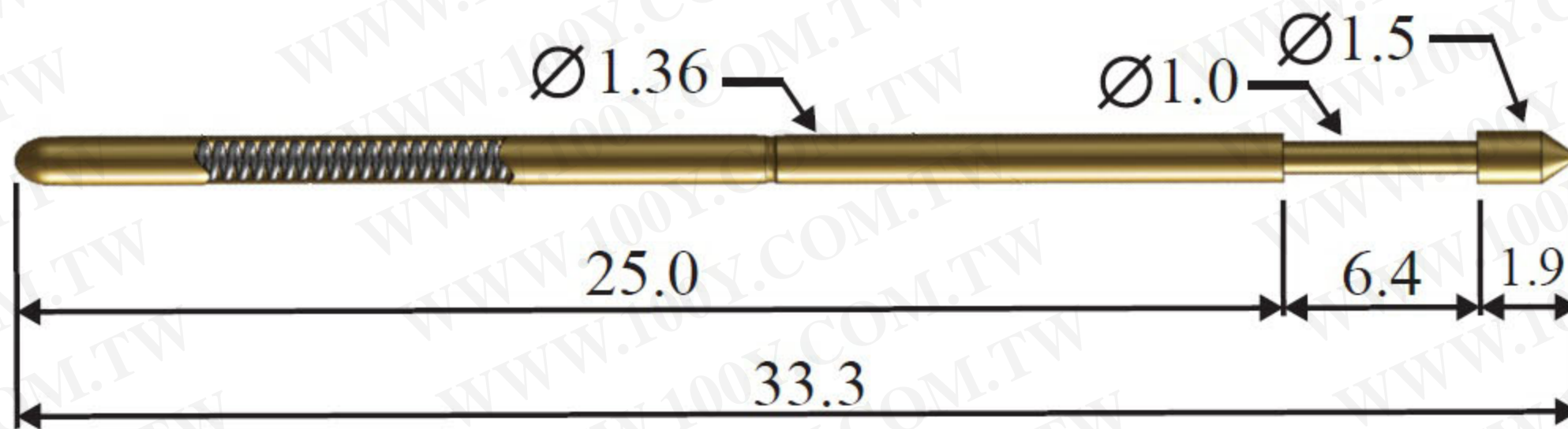

# Timejet TR-136C

size:1.66  
unit:mm(inch)

## How to Order (★ Customized)

<b>TJ</b>	<b>-136</b>	<b>C</b>	<b>02</b>	<b>A</b>	<b>100</b>	<b>100</b>	<b>A</b>
Serie	Size	Length	Tip	Tip Plating	Outer	Spring Force	Tube Plating
				A:Gold ★R:Rh		100:100g 200:200g 300:300g	A:Gold N:Nickel Silver

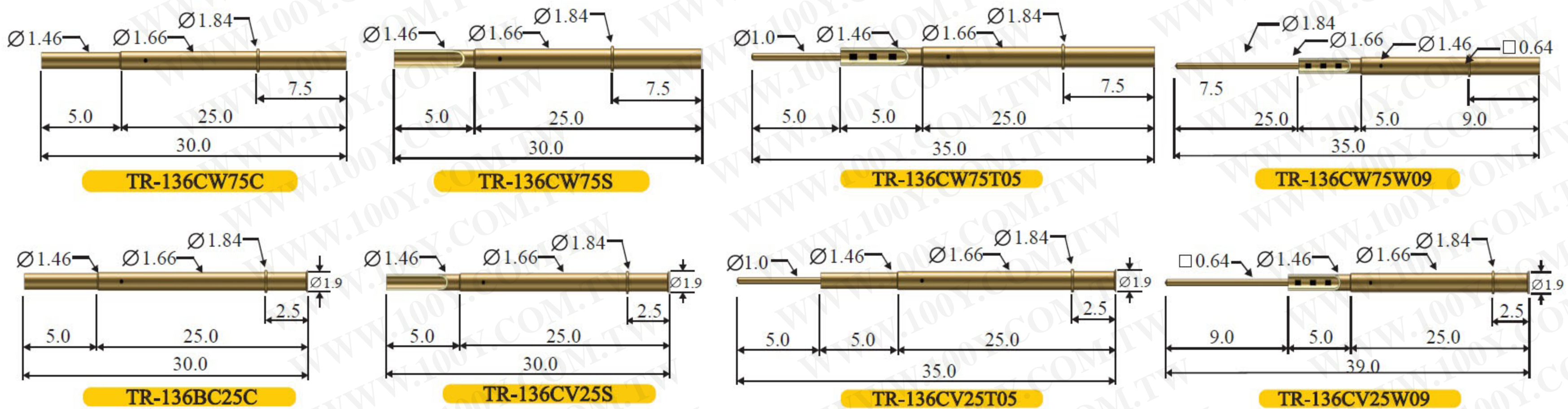

## How to Order

<b>TR</b>	<b>-136</b>	<b>C</b>	<b>W</b>	<b>25</b>	<b>C</b>	<b>05</b>
Serie	Size	Length	Style	Distance of Press-Ring	Terminal	Pin-Length
			V:V type 1 Ring W: Straight type 1 Rings	25:2.5 75:7.5	C:Crimp S:Solder Cup W:Square Pin T:Circular Pin	05:5mm 09:9mm

### Material Data

針軸 Plunger  
高碳鋼鍍金 SK4 with Gold Plated  
內管 Barrel  
磷青銅鍍金 Phosphor Bronze with Gold Plated  
彈簧 Spring  
琴鋼線鍍金 Music Wire with Gold Plated  
外管 Receptacle  
黃銅鍍金 Brass with Gold Plated

### Electrical Data

最小中心距 Min. Center  
2.54mm (0.01")  
建議鑽孔尺寸 Recommended Hole Size  
1.7mm~1.75mm (0.0669" ~ 0.0689")  
額定電流 Current Rating  
3A (安培)  
接觸電阻 Contact Resistance  
30mΩ (毫歐姆)

### Mechanical Data

工作行程 Working Stroke  
4.2mm (0.1653")  
最大行程 Maximum Stroke  
6.4mm (0.2519")  
行程彈力 Spring Force at Stroke  
100g,200g,300g

# TJ-201

size:2.01

unit:mm(inch)

## TJ serie PCB Probe

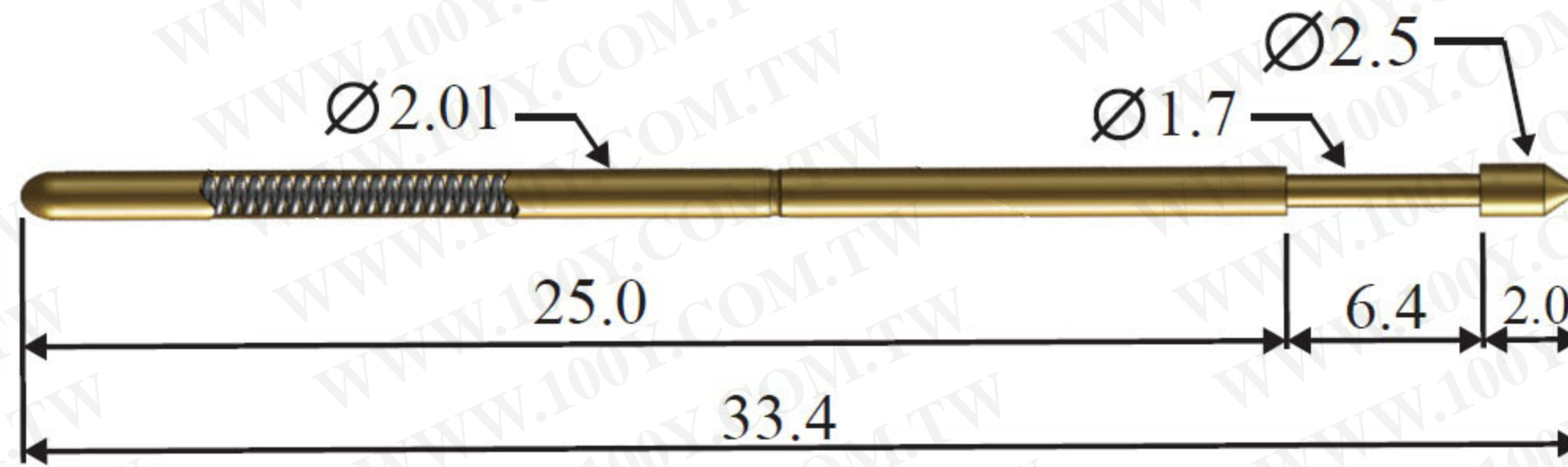

### Plunger Tips

02	30°	Ø1.7	06	Ø2.5
11	90°	Ø2.5	12	Ø2.5
14		Ø2.5	15	Ø1.7
19		Ø2.5	20	Ø2.5

## Timejet TR-201

size:2.36  
unit:mm(inch)

### How to Order (★ Customized)

<b>TJ</b>	<b>- 201</b>	<b>02</b>	<b>A</b>	<b>170</b>	<b>200</b>	<b>A</b>
Series	Size	Tip	Tip Plating	Outer	Spring Force	Tube Plating
			A:Gold ★ R:Rh			A:Gold N:Nickel Silver

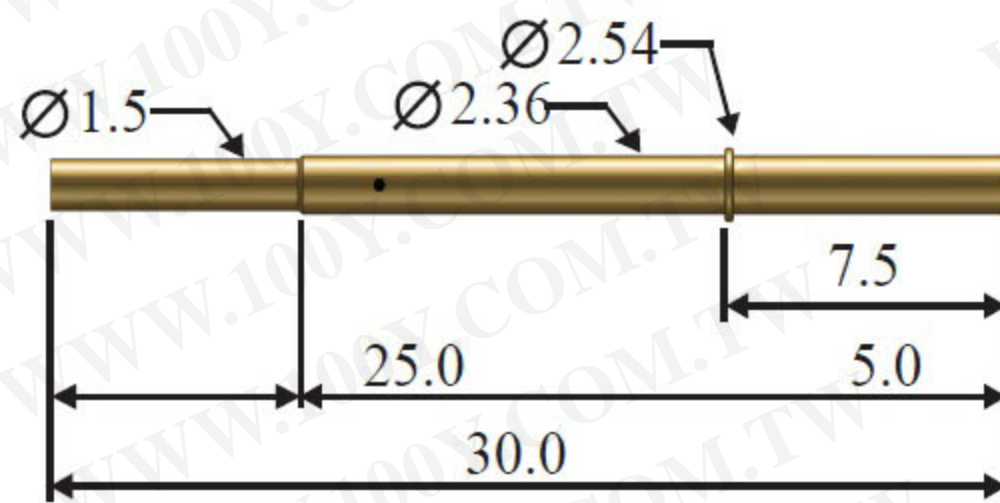

TR-201W75C

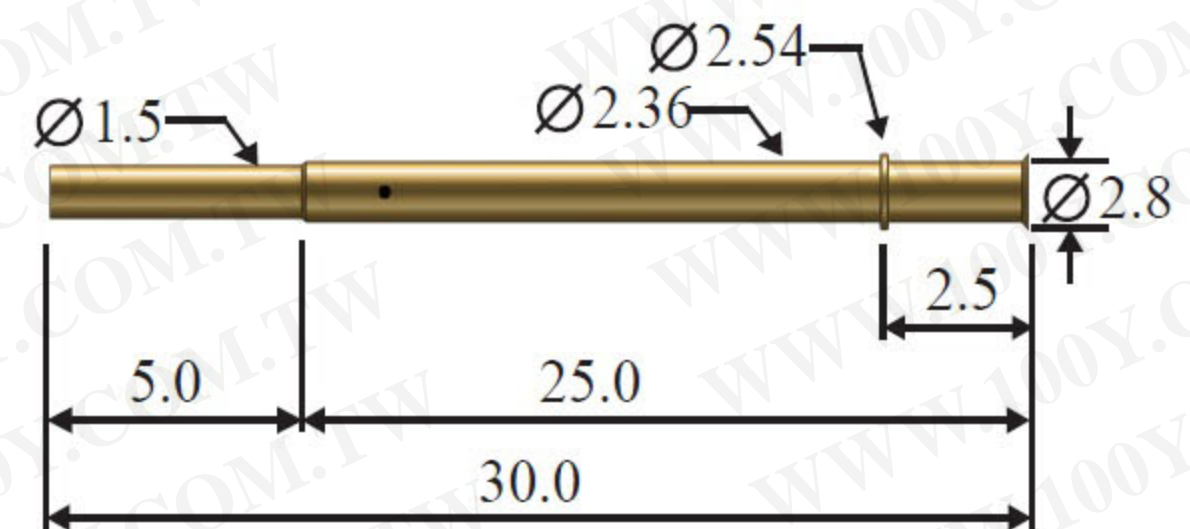

TR-201V25C

### How to Order

<b>TR</b>	<b>- 201</b>	<b>W</b>	<b>75</b>	<b>C</b>
Series	Size	Style	Distance of Press-Ring	Terminal
		V:V type 1 Ring W: Straight type 1 Rings	25:2.5 75:7.5	C:Crimp

### Material Data

針軸 Plunger  
高碳鋼鍍金 SK4 with Gold Plated  
內管 Barrel  
磷青銅鍍金 Phosphor Bronze with Gold Plated  
彈簧 Spring  
琴鋼線鍍金 Music Wire with Gold Plated  
外管 Receptacle  
黃銅鍍金 Brass with Gold Plated

### Electrical Data

最小中心距 Min. Center  
2.54mm ( 0.100" )  
建議鑽孔尺寸 Recommended Hole Size  
1.7mm~1.75mm( 0.0669" ~ 0.0689" )  
額定電流 Current Rating  
3A( 安培 )  
接觸電阻 Contact Resistance  
100mΩ( 毫歐姆)

### Mechanical Data

工作行程 Working Stroke  
4.2mm ( 0.1653" )  
最大行程 Maximum Stroke  
6.4mm ( 0.2519" )  
工作行程彈力 Spring Force at Working Stroke  
200g

# TJ-234

size:2.34

unit:mm(inch)

# TJ serise PCB Probe

## Plunger Tips

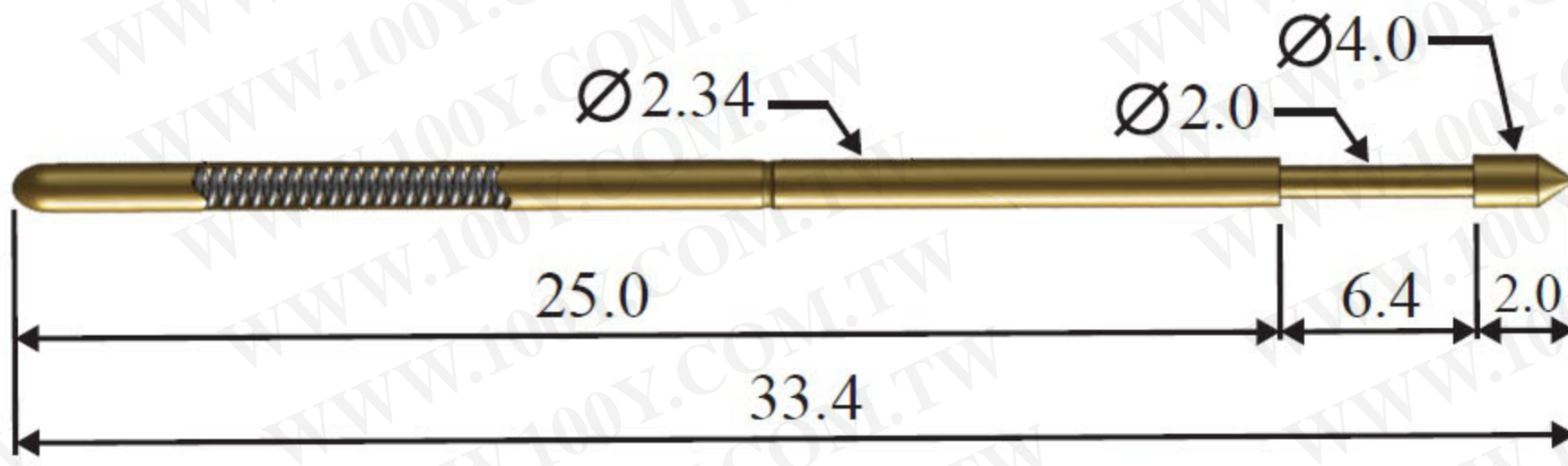

02	45°	06
11		12
14		15
19		

# Timejet TR-234

size:2.69  
unit:mm(inch)

## How to Order (★ Customized)

<b>TJ</b>	<b>- 234</b>	<b>02</b>	<b>A</b>	<b>040</b>	<b>200</b>	<b>A</b>
Series	Size	Tip	Tip Plating	Outer	Spring Force	Tube Plating
			A:Gold ★ R:Rh			A:Gold N:Nickel Silver

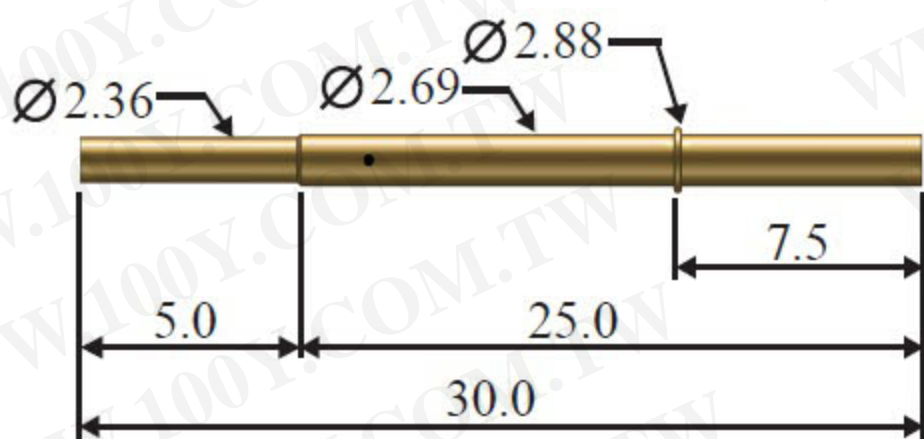

TR-234W75C

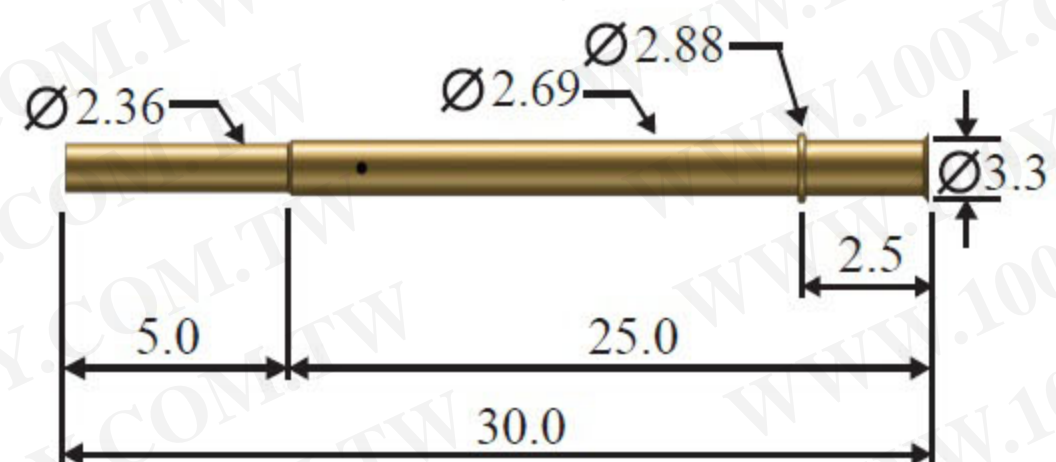

TR-234V25C

## How to Order

<b>TR</b>	<b>- 234</b>	<b>W</b>	<b>75</b>	<b>C</b>
Series	Size	Style	Distance of Press-Ring	Terminal
		V:V type 1 Ring W: Straight type 1 Rings	25:2.5 75:7.5	C:Crimp

### Material Data

針軸 Plunger  
高碳鋼鍍金 SK4 with Gold Plated  
內管 Barrel  
磷青銅鍍金 Phosphor Bronze with Gold Plated  
彈簧 Spring  
琴鋼線鍍金 Music Wire with Gold Plated  
外管 Receptacle  
黃銅鍍金 Brass with Gold Plated

### Electrical Data

最小中心距 Min. Center  
2.54mm (0.100")  
建議鑽孔尺寸 Recommended Hole Size  
1.7mm~1.75mm (0.0669" ~ 0.0689")  
額定電流 Current Rating  
3A (安培)  
接觸電阻 Contact Resistance  
100mΩ(毫歐姆)

### Mechanical Data

工作行程 Working Stroke  
4.2mm (0.1653")  
最大行程 Maximum Stroke  
6.4mm (0.2519")  
2/3 行程彈力 2/3 Spring Force at Stroke  
200g

# TC-039

size:0.61

unit:mm(inch)

## TC serie ICT Probe

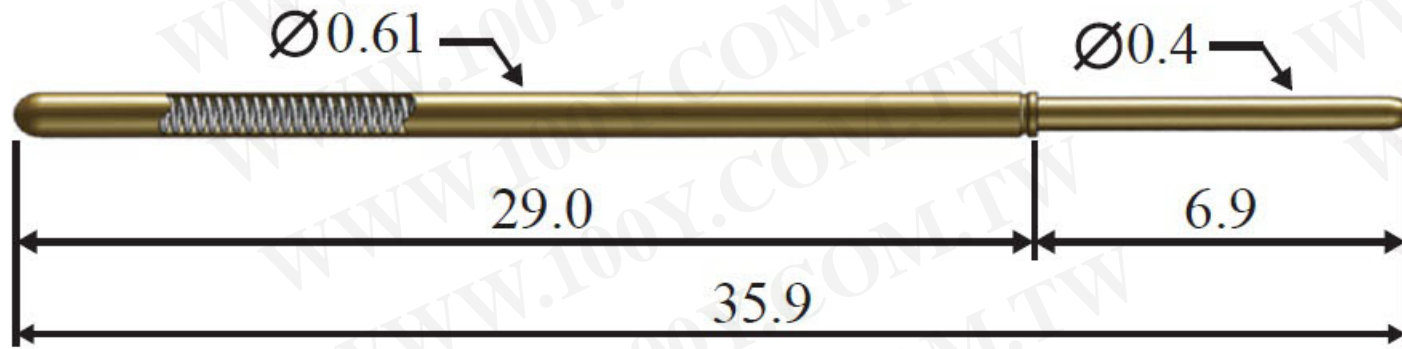

### Plunger Tips

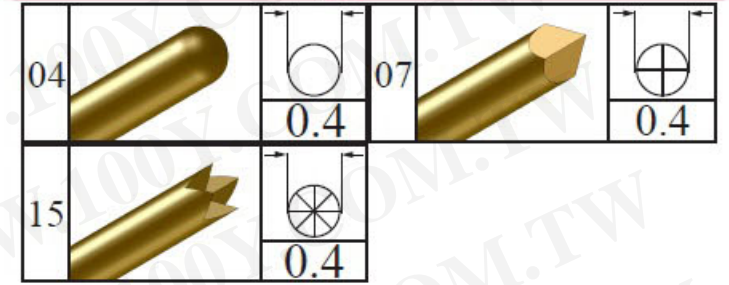

## Timejet CR-039

size:0.77  
unit:mm(inch)

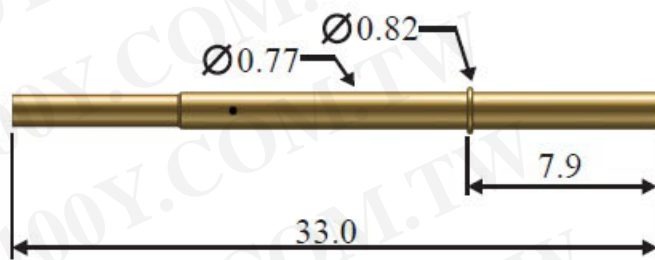

CR-039W79C



CR-039W79W700

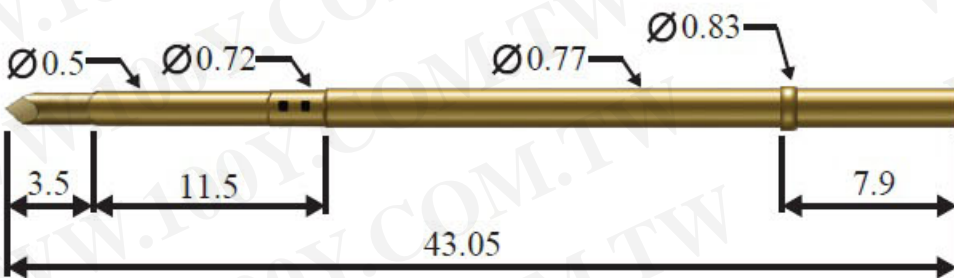

CR-039W79L

### How to Order

<b>TC-039</b>	<b>04</b>	<b>A</b>	<b>040</b>	<b>200</b>	<b>A</b>
Series	Size	Tip	Tip Plating A:Gold	Outer Spring Force	Tube Plating A:Gold N:Nickel Silver

### How to Order

<b>CR-039</b>	<b>W</b>	<b>79</b>	<b>C</b>	<b>70</b>	<b>28</b>
Series	Size	Style W: Straight type 1 Rings	Terminal C: Crimp W: Wire Wrap ★ I: Insertion Wire L: Wireless	Wire-Length 60: 600mm 70: 700mm	Wire-Size 28 30

### Material Data

針軸 Plunger  
高碳鋼鍍金 SK4 with Gold Plated  
內管 Barrel  
黃銅鍍金 Brass with Gold Plated  
彈簧 Spring  
琴鋼線鍍金 Music Wire with Gold Plated  
外管 Receptacle  
黃銅鍍金 Brass with Gold Plated

### Electrical Data

最小中心距 Min. Center  
1.0mm ( 0.039 )  
建議鑽孔尺寸 Recommended Hole Size  
0.79mm~0.80mm( 0.0311 ~ 0.0315 )  
額定電流 Current Rating  
2A( 安培 )  
接觸電阻 Contact Resistance  
20mΩ( 毫歐姆 )

### Mechanical Data

工作行程 Working Stroke  
4.3mm ( 0.169 )  
最大行程 Maximum Stroke  
6.35mm ( 0.250 )  
工作行程彈力 Spring Force at Working Stroke  
200g

# TC-050A

size:0.78

unit:mm(inch)

# TC serie ICT Probe

## Plunger Tips

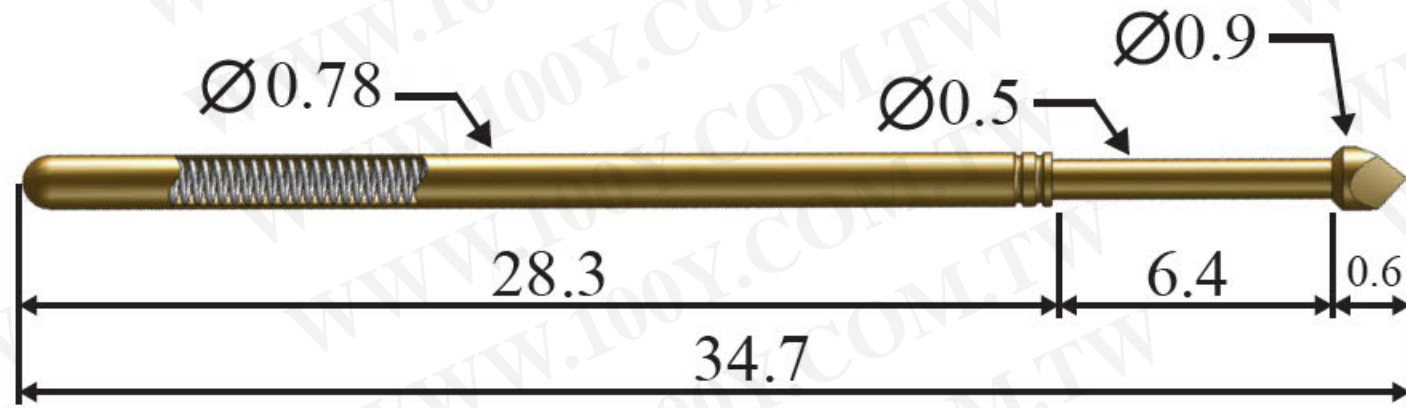

02	30°			04		
			0.5			0.5
08				15		
			0.5			0.5
17	30°			19		
			0.5			0.9
28	30°					
			0.9			

## Timejet CR-050A size:0.95 unit:mm(inch)

### How to Order

<b>TC</b>	<b>-050</b>	<b>A</b>	<b>02</b>	<b>A</b>	<b>050</b>	<b>100</b>	<b>A</b>
Serie	Size	Length	Tip	Tip Plating	Outer	Spring Force	Tube Plating
	A		A:Gold	050:0.5 090:0.9	100:100g 200:200g 300:300g	A:Gold N:Nickel Silver	

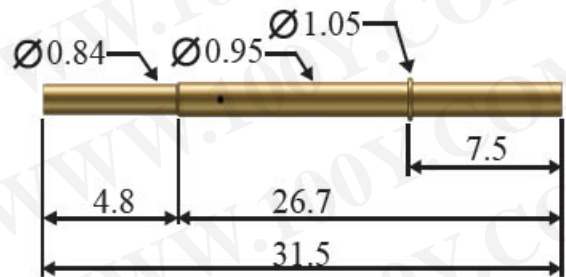

CR-050AW75C

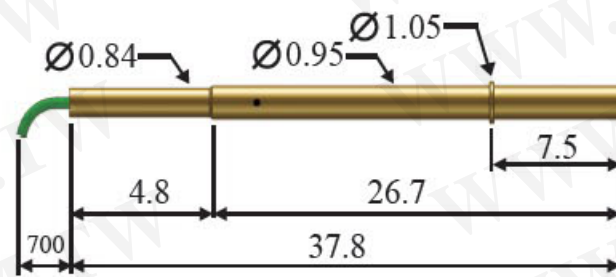

CR-050AW75W700

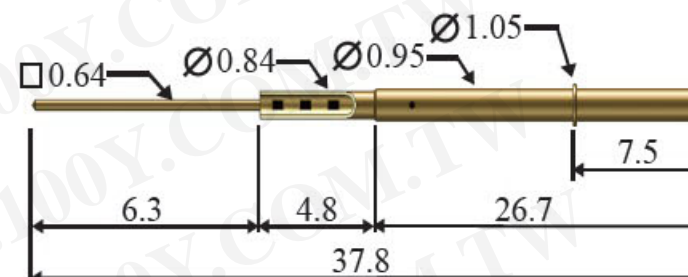

CR-050AW75W0630

### How to Order

<b>CR</b>	<b>-050</b>	<b>A</b>	<b>W</b>	<b>75</b>	<b>C</b>	<b>70</b>	<b>28</b>	<b>0630</b>
Serie	Size	Length	Style	Distance of Press-Ring	Terminal	Wire-Length	Wire-Size	Pin-Length
	A		W: Straight type 1 Rings	75:7.5	C: Crimp W: Square Pin (Wire Wrap)	60:600mm 70:700mm	28 30	0630:6.3mm 0635:6.35mm

### Material Data

針軸 Plunger  
高碳鋼鍍金 SK4 with Gold Plated  
內管 Barrel  
黃銅鍍金 Brass with Gold Plated  
彈簧 Spring  
琴鋼線鍍金 Music Wire with Gold Plated  
外管 Receptacle  
黃銅鍍金 Brass with Gold Plated

### Electrical Data

最小中心距 Min. Center  
1.27mm ( 0.050 )  
建議鑽孔尺寸 Recommended Hole Size  
0.96mm~0.98mm( 0.0378 ~ 0.0386 )  
額定電流 Current Rating  
2A~3A( 安培 )  
接觸電阻 Contact Resistance  
20mΩ( 毫歐姆)

### Mechanical Data

工作行程 Working Stroke  
4.3mm ( 0.169 )  
最大行程 Maximum Stroke  
6.4mm ( 0.251 )  
工作行程彈力 Spring Force at Working Stroke  
100g,200g,300g

# TC-050B

size:0.78

unit:mm(inch)

## TC serie ICT Probe

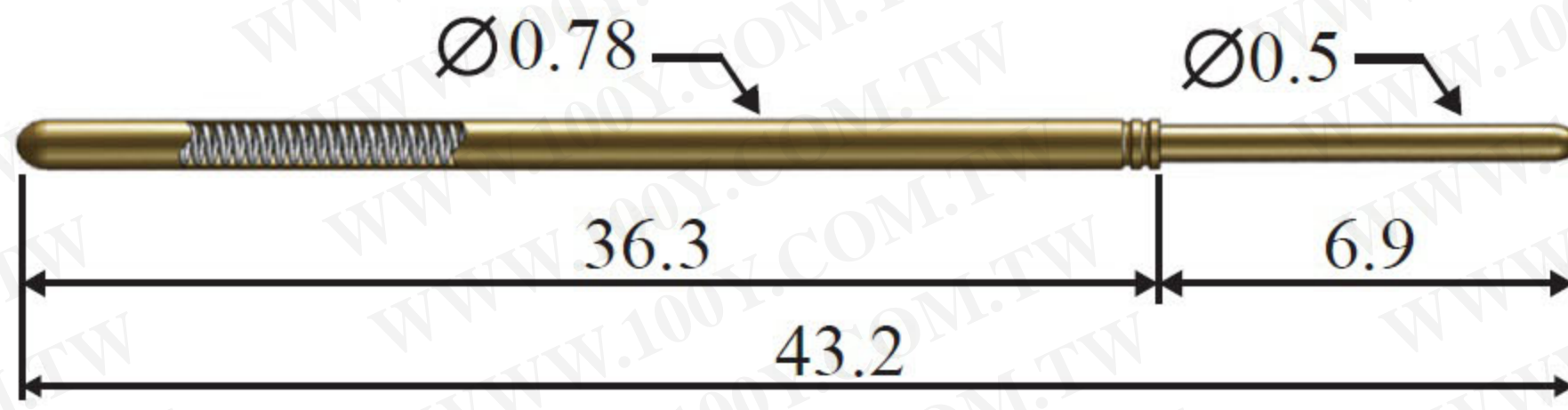

### Plunger Tips

02	30°	Ø0.5	08	Ø0.5
10	90°	Ø0.5	11	Ø0.97
15	30°	Ø0.5	17	Ø0.5
19	30°	Ø0.97	28	Ø0.9

## Timejet CR-050B

size:0.95  
unit:mm(inch)

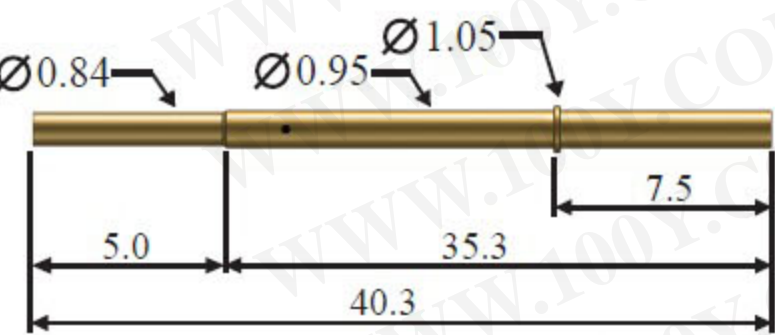

CR-050BW75C

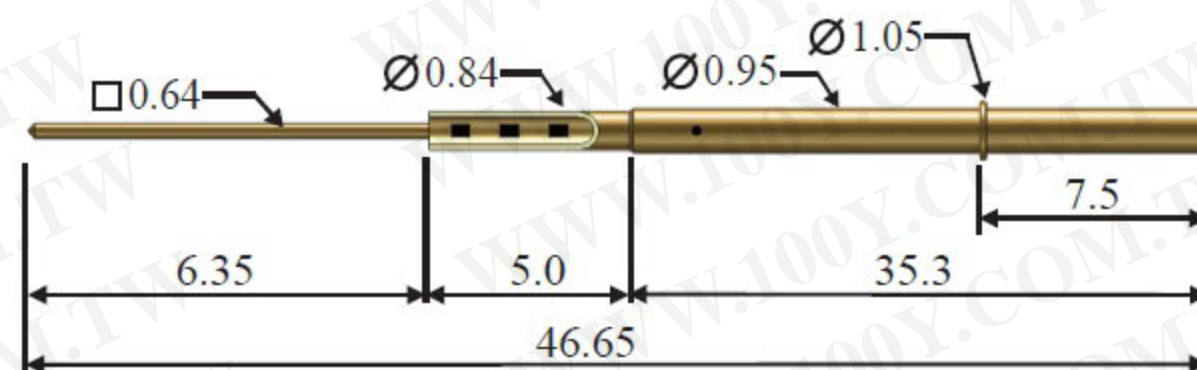

CR-050BW75(W)0635

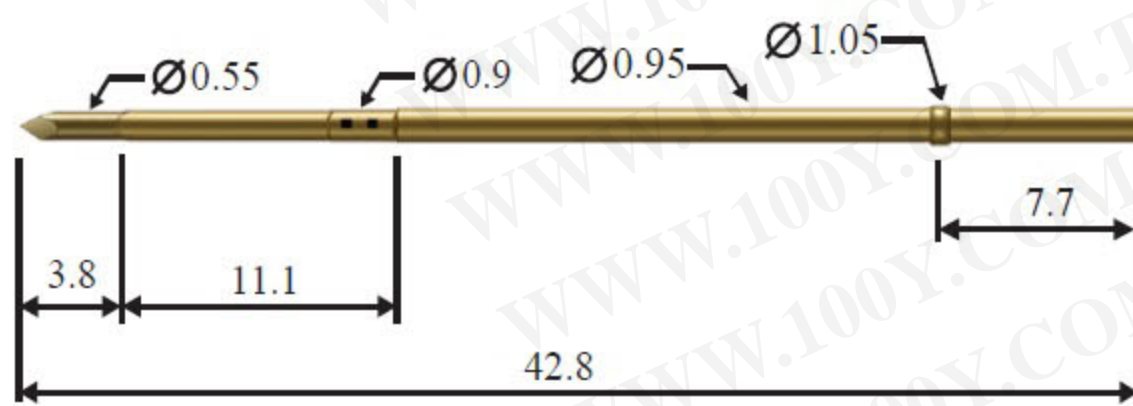

CR-050BW77L

### How to Order

<b>TC-050</b>	<b>B</b>	<b>02</b>	<b>A</b>	<b>050</b>	<b>100</b>	<b>A</b>
Series	Size	Length B	Tip A:Gold	Outer	Spring Force 200:200g 300:300g	Tube Plating A:Gold N:Nickel Silver

### How to Order

<b>CR-050</b>	<b>B</b>	<b>W</b>	<b>75</b>	<b>C</b>	<b>70</b>	<b>0630</b>	
Series	Size	Length B	Style W: Straight type 1 Rings	Distance of Press-Ring 75:7.5 77:7.7	Terminal C: Crimp S: Solder Cup W: Square Pin (Wire Wrap) I: Insertion Wire L: Wireless	Wire-Length 60:600mm 70:700mm	Pin-Length 0630:6.3mm 0635:6.35mm

### Material Data

針軸 Plunger  
高碳鋼鍍金 SK4 with Gold Plated  
內管 Barrel  
黃銅鍍金 Brass with Gold Plated  
彈簧 Spring  
琴鋼線鍍金 Music Wire with Gold Plated  
外管 Receptacle  
黃銅鍍金 Brass with Gold Plated

### Electrical Data

最小中心距 Min. Center  
1.27mm ( 0.050 )  
建議鑽孔尺寸 Recommended Hole Size  
0.96mm~0.98mm( 0.0378 ~ 0.0386 )  
額定電流 Current Rating  
2A~3A( 安培 )  
接觸電阻 Contact Resistance  
20mΩ( 毫歐姆)

### Mechanical Data

工作行程 Working Stroke  
4.3mm ( 0.169 )  
最大行程 Maximum Stroke  
6.4mm ( 0.251 )  
工作行程彈力 Spring Force at Working Stroke  
200g,300g

# TC-075

size:1.01

unit:mm(inch)

## TC serie ICT Probe

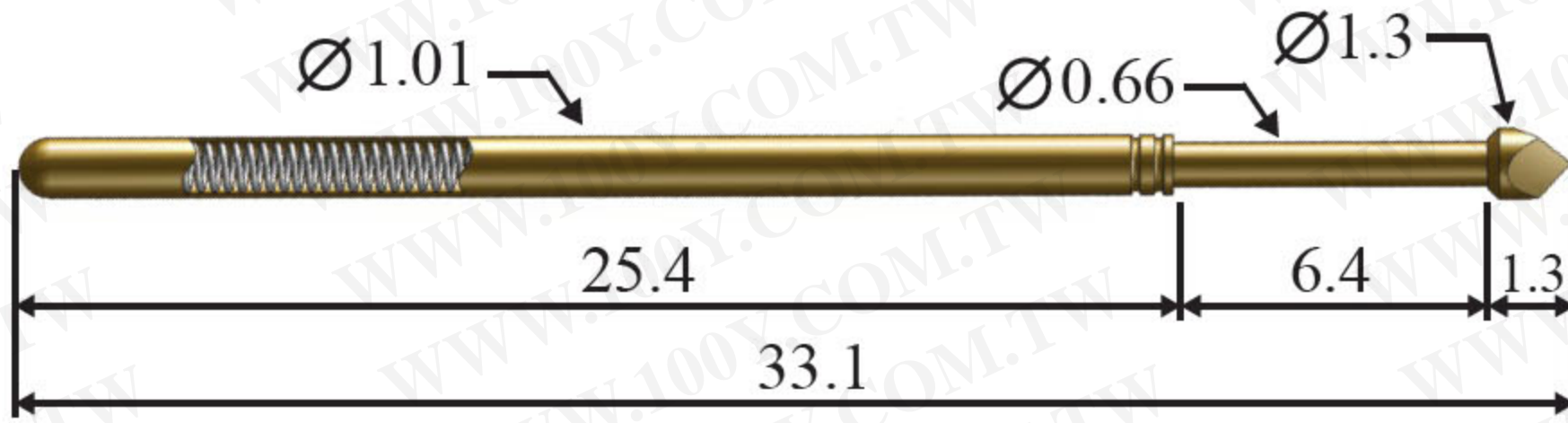

### Plunger Tips

02		0.64	03		0.65
04		0.64	06		1.3
08		0.64	11		1.3
15		0.64	17		0.64
19		1.3	25		0.5
28		1.3	52		1.3
63		1.2	76		1.3
			86		1.3

### How to Order

<b>TC-075</b>	<b>02</b>	<b>A</b>	<b>064</b>	<b>100</b>	<b>A</b>
Series	Size	Tip	Tip Plating	Outer	Spring Force
			A:Gold		100:100g 200:200g 300:300g
					Tube Plating
					A:Gold N:Nickel Silver

## Timejet CR-075

size:1.31  
unit:mm(inch)

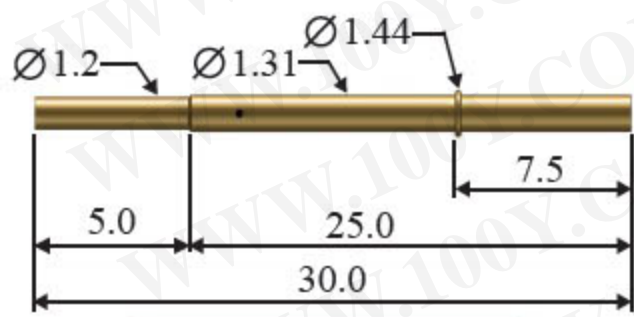

CR-075W75C

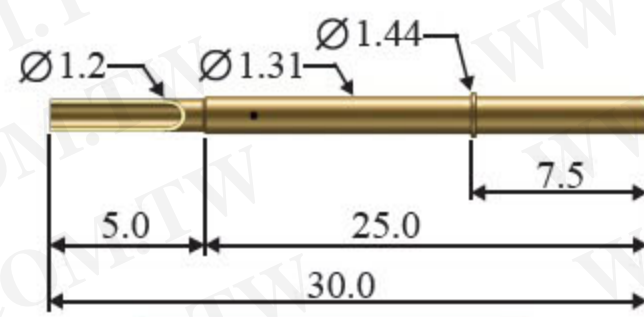

CR-075W75S

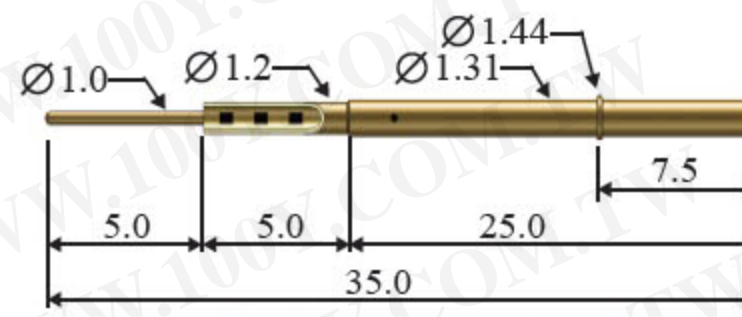

CR-075W75T05

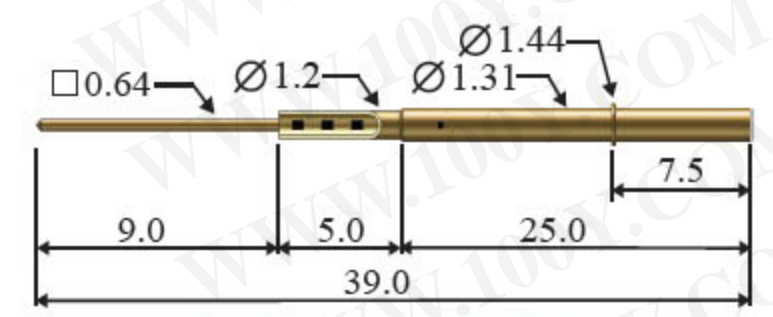

CR-075W75(W)09

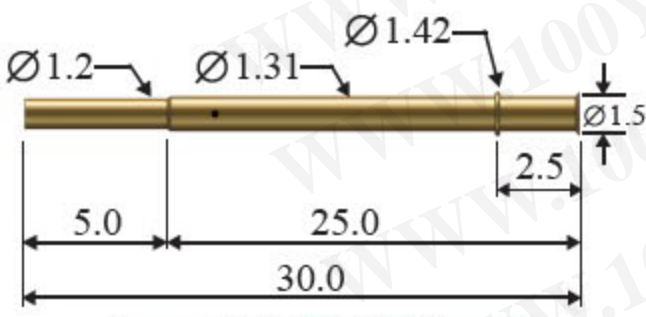

CR-075V25C

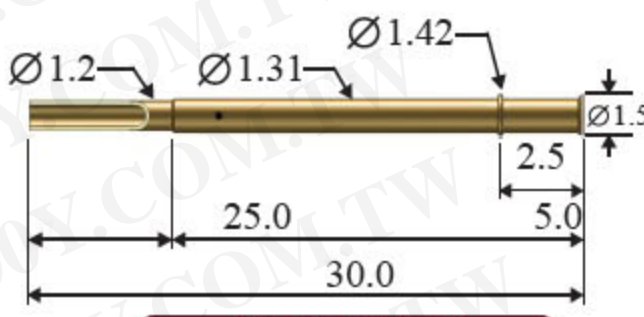

CR-075V25S

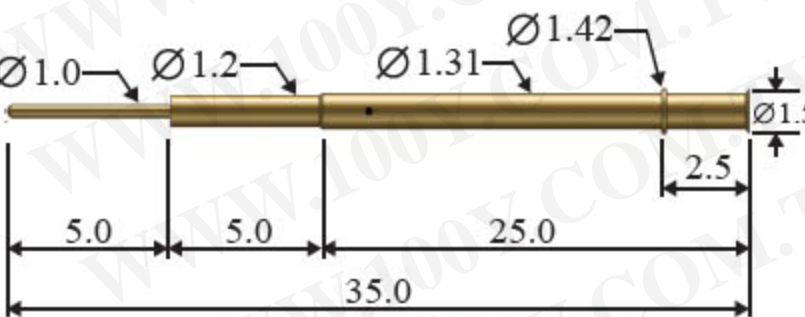

CR-075V25T05

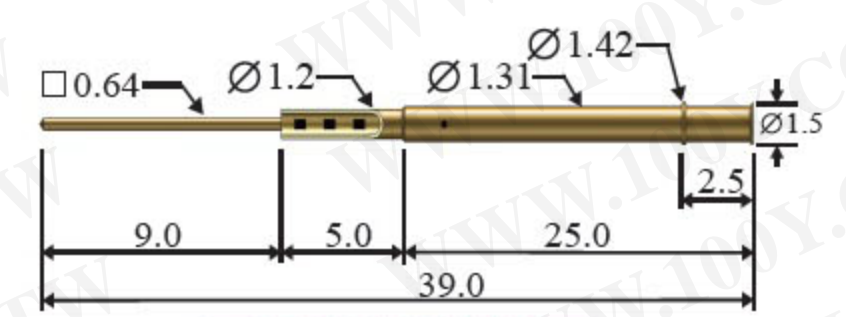

CR-075V25(W)09

### How to Order (★Customized)

<b>CR-075</b>	<b>W</b>	<b>75</b>	<b>C</b>	<b>70</b>	<b>28</b>	<b>05</b>
Series	Size	Style	Terminal	★Wire-Length	★Wire-Size	Pin-Length
		V:V type 1 Ring W: Straight type 1 Rings	C:Crimp S:Solder Cup W: Square Pin (★Wire Wrap) T:Circular Pin	60:600mm 70:700mm	28 30	05:5mm 09:9mm
		Distance of Press-Ring				
		25:2.5 75:7.5				

### Material Data

針軸 Plunger  
高碳鋼鍍金 SK4 with Gold Plated  
內管 Barrel  
黃銅鍍金 Brass with Gold Plated  
彈簧 Spring  
琴鋼線鍍金 Music Wire with Gold Plated  
外管 Receptacle  
黃銅鍍金 Brass with Gold Plated

### Electrical Data

最小中心距 Min. Center  
1.91mm ( 0.075 )  
建議鑽孔尺寸 Recommended Hole Size  
1.36mm~1.40mm( 0.0535 ~ 0.0551 )  
額定電流 Current Rating  
3A~4A( 安培 )  
接觸電阻 Contact Resistance  
20mΩ( 毫歐姆)

### Mechanical Data

工作行程 Working Stroke  
4.3mm ( 0.169 )  
最大行程 Maximum Stroke  
6.4mm ( 0.251 )  
工作行程彈力 Spring Force at Working Stroke  
100g,200g,300g

# TC-100

size:1.36

unit:mm(inch)

## TC serie ICT Probe

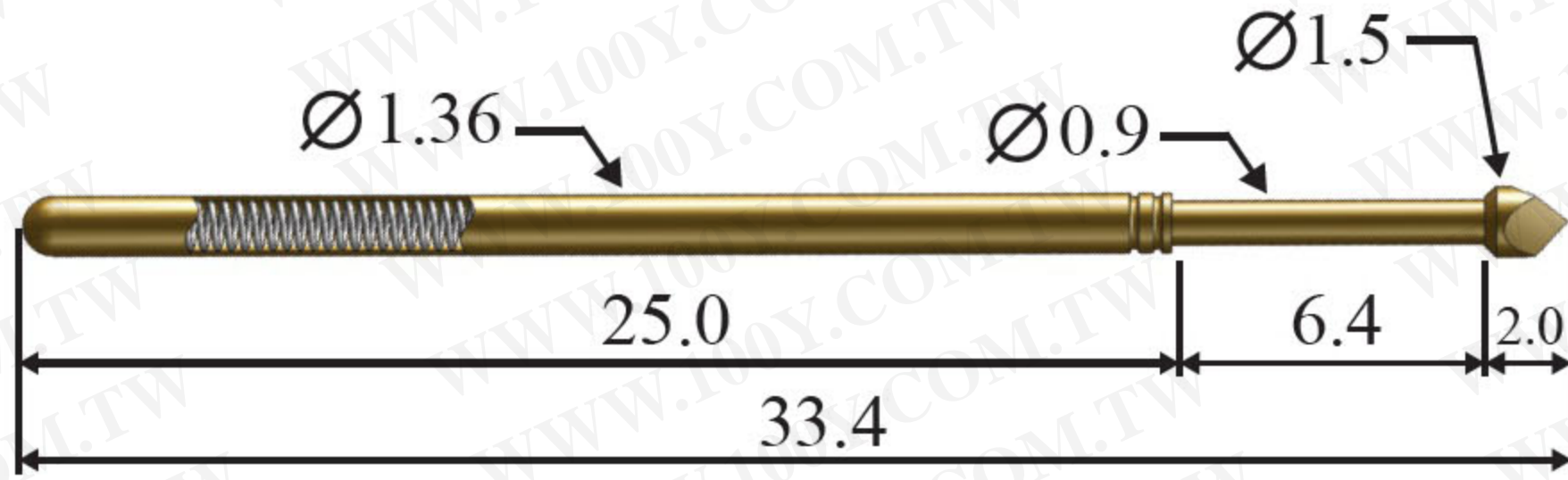

### Plunger Tips

03		0.9	04		0.9
06		1.3 1.5	08		0.9
11		1.5	15		0.9
16		1.3 1.5	17		0.9
18		0.9	19		1.5
24		0.9	25		0.5
28		1.5 2.0 3.0	63		1.4
67		1.3 1.5	76		1.3 1.5
			86		1.5

## Timejet CR-100

size:1.66  
unit:mm(inch)

### How to Order

<b>TC-100</b>	<b>03</b>	<b>A</b>	<b>050</b>	<b>100</b>	<b>A</b>
Series	Size	Tip	Tip Plating	Outer	Spring Force
			A:Gold		100:100g 200:200g 300:300g
					Tube Plating
					A:Gold N:Nickel Silver

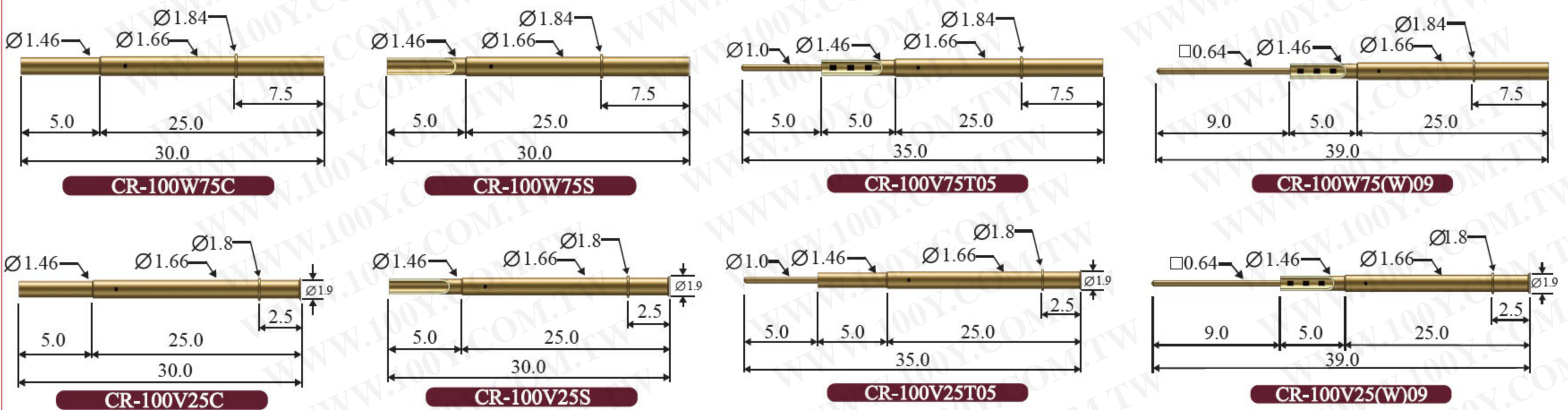

### How to Order

<b>CR-100</b>	<b>W</b>	<b>75</b>	<b>C</b>	<b>05</b>
Series	Size	Style	Distance of Press-Ring	Terminal
		V:V type 1 Ring W: Straight type 1 Rings	25:2.5 75:7.5	C:Crimp S:Solder Cup W:Square Pin T:Circular Pin
				Pin-Length
				05:5mm 09:9mm

### Material Data

針軸 Plunger  
高碳鋼鍍金 SK4 with Gold Plated  
內管 Barrel  
黃銅鍍金 Brass with Gold Plated  
彈簧 Spring  
琴鋼線鍍金 Music Wire with Gold Plated  
外管 Receptacle  
黃銅鍍金 Brass with Gold Plated

### Electrical Data

最小中心距 Min. Center  
2.54mm (0.1)  
建議鑽孔尺寸 Recommended Hole Size  
1.7mm~1.75mm(0.669 ~ 0.689)  
額定電流 Current Rating  
5A~8A(安培)  
接觸電阻 Contact Resistance  
20mΩ

### Mechanical Data

工作行程 Working Stroke  
4.3mm (0.169)  
最大行程 Maximum Stroke  
6.4mm (0.251)  
工作行程彈力 Spring Force at Working Stroke  
100g,200g,300g

# TJ-020

size:0.2

unit:mm(inch)

## TJ serie PCB Probe

### Plunger Tips

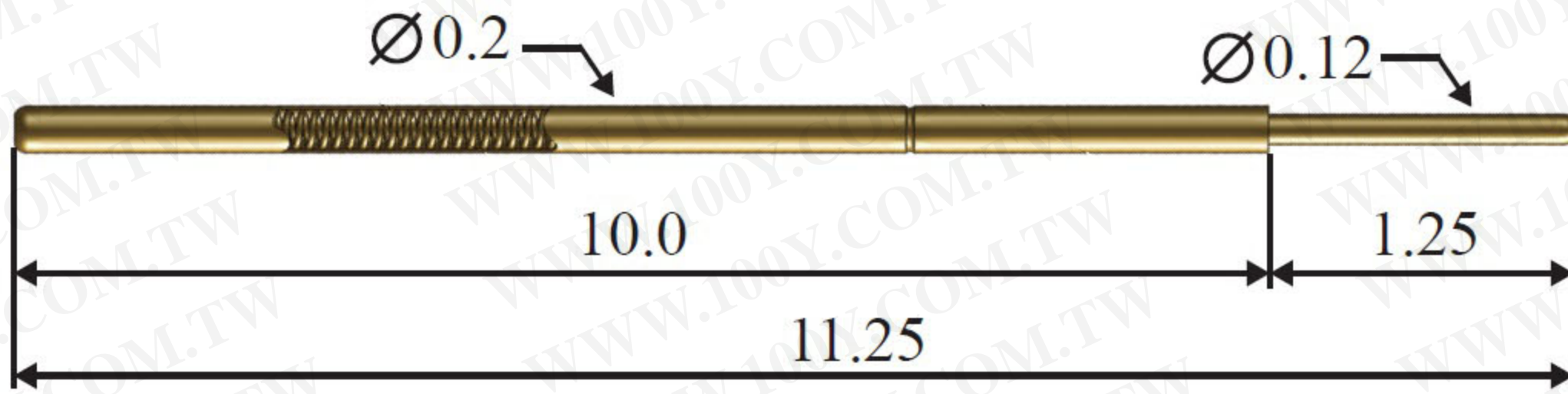

## Timejet TR-020

size:0.3  
unit:mm(inch)

### How to Order (★ Customized)

<b>TJ</b>	<b>- 020</b>	<b>02</b>	<b>A</b>	<b>012</b>	<b>010</b>	<b>A</b>
Series	Size	Tip	Tip Plating A:Gold	Outer	Spring Force	Tube Plating A:Gold

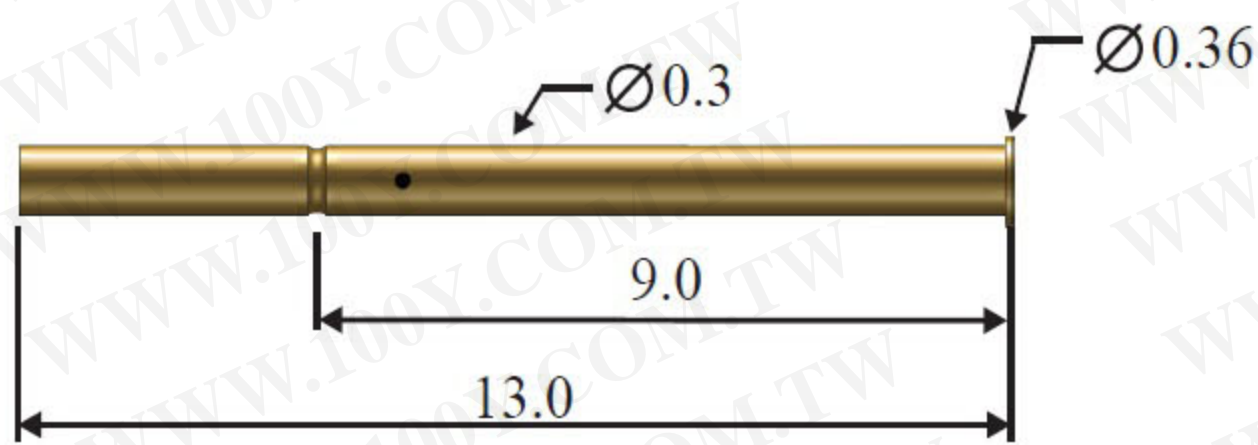

★ TR-020UCC

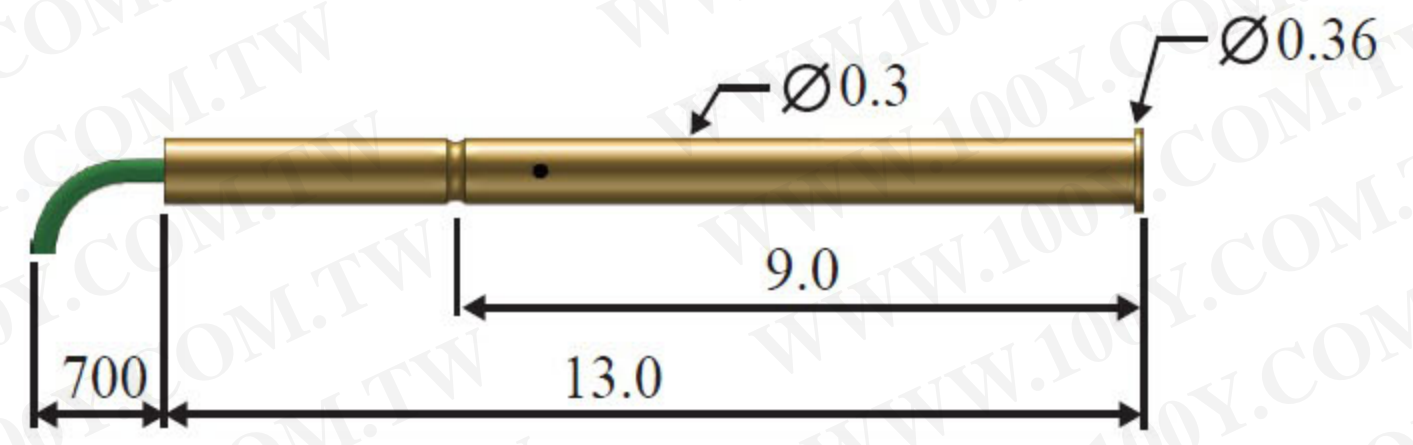

★ TR-020UCW

### How to Order (★ Customized)

<b>TR</b>	<b>- 020</b>	<b>UC</b>	<b>C</b>	<b>70</b>
Series	Size	Style ★UC:V type No Rings by CNC	Terminal C:Crimp W:Wire Wrap	Wire-Length 70:700mm

### Material Data

針軸 Plunger  
高碳鋼鍍金 SK4 with Gold Plated  
內管 Barrel  
磷青銅鍍金 Phosphor Bronze with Gold Plated  
彈簧 Spring  
琴鋼線鍍金 Music Wire with Gold Plated  
外管 Receptacle  
黃銅鍍金 Brass with Gold Plated

### Electrical Data

最小中心距 Min. Center  
0.5mm ( 0.0197" )  
建議鑽孔尺寸 Recommended Hole Size  
0.32mm( 0.0126" )  
額定電流 Current Rating  
0.3A( 安培 )  
接觸電阻 Contact Resistance  
260mΩ( 毫歐姆)

### Mechanical Data

工作行程 Working Stroke  
0.85mm ( 0.0334" )  
最大行程 Maximum Stroke  
1.25mm ( 0.0492" )  
工作行程彈力 Spring Force at Working Stroke  
10g

# TJ-025

size:0.25

unit:mm(inch)

## TJ serise PCB Probe

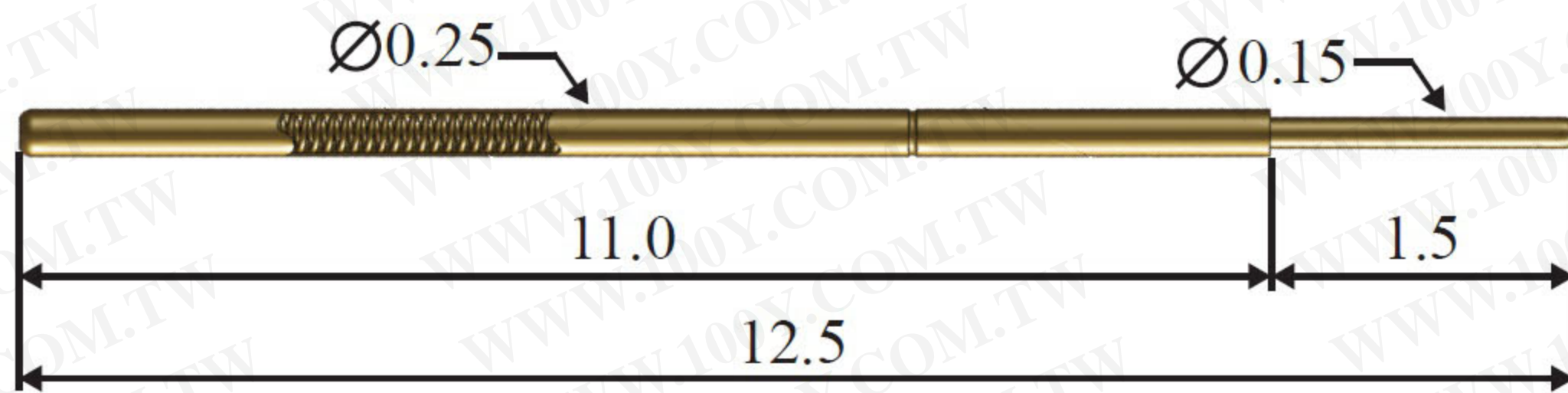

### Plunger Tips

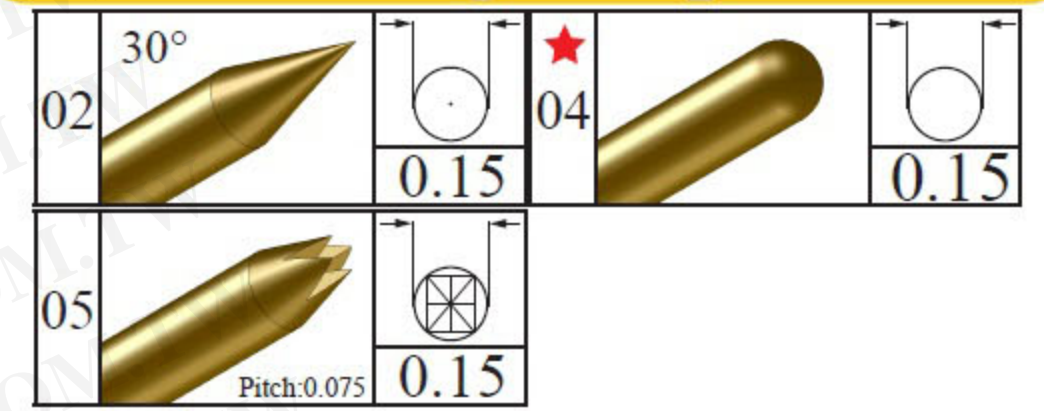

## Timejet TR-025

size:0.35  
unit:mm(inch)

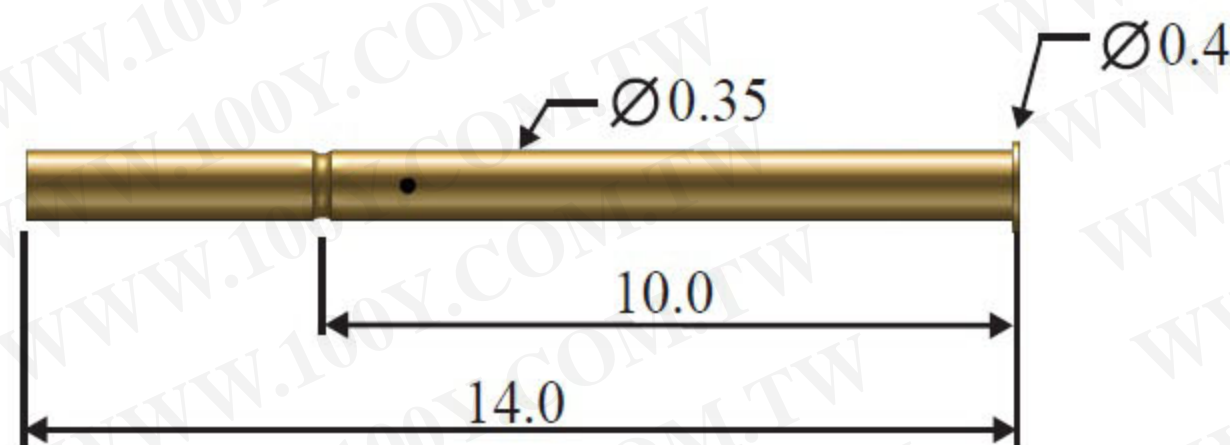

★ TR-025UCC

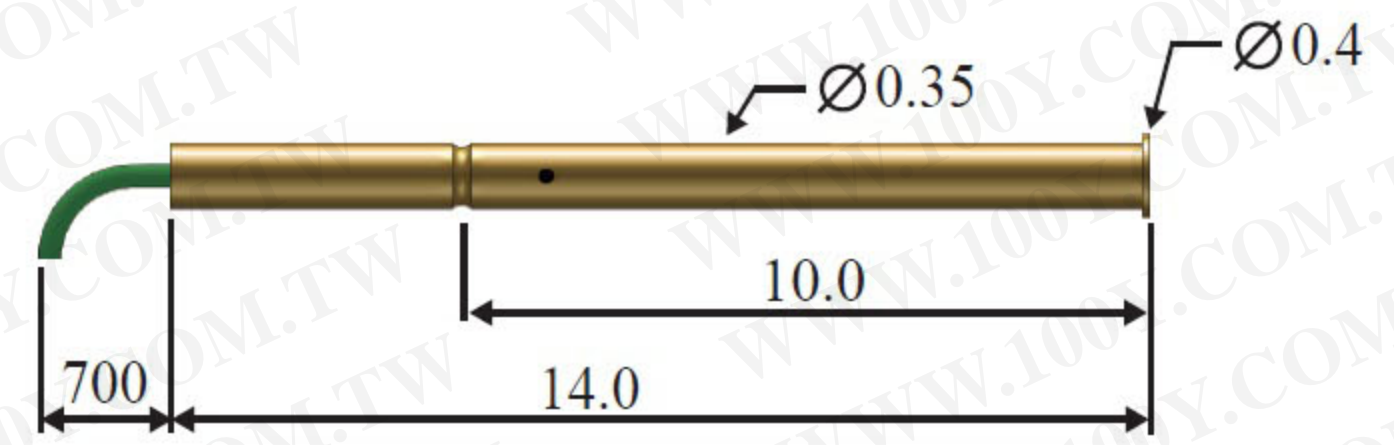

★ TR-025UCW

### How to Order (★ Customized)

<b>TJ</b>	<b>-025</b>	<b>02</b>	<b>A</b>	<b>015</b>	<b>015</b>	<b>A</b>
Series	Size	Tip	Tip Plating	Outer	Spring Force	Tube Plating
			A:Gold ★R:Rh			A:Gold ★N:Nickel Silver

### How to Order (★ Customized)

<b>TR</b>	<b>-025</b>	<b>UC</b>	<b>C</b>	<b>70</b>
Series	Size	Style	Terminal	Wire-Length
		★UC:V type No Rings by CNC	C:Crimp W:Wire Wrap	70:700mm

### Material Data

針軸 Plunger  
高碳鋼鍍金 SK4 with Gold Plated  
內管 Barrel  
磷青銅鍍金 Phosphor Bronze with Gold Plated  
彈簧 Spring  
琴鋼線鍍金 Music Wire with Gold Plated  
外管 Receptacle  
黃銅鍍金 Brass with Gold Plated

### Electrical Data

最小中心距 Min. Center  
0.5mm ( 0.0197" )  
建議鑽孔尺寸 Recommended Hole Size  
0.368mm~0.38mm( 0.0145"~0.015" )  
額定電流 Current Rating  
0.3A( 安培 )  
接觸電阻 Contact Resistance  
220mΩ( 毫歐姆)

### Mechanical Data

工作行程 Working Stroke  
1mm ( 0.0393" )  
最大行程 Maximum Stroke  
1.5mm ( 0.0590" )  
工作行程彈力 Spring Force at Working Stroke  
15g

# TJ-030

size:0.3

unit:mm(inch)

## TJ serie PCB Probe

### Plunger Tips

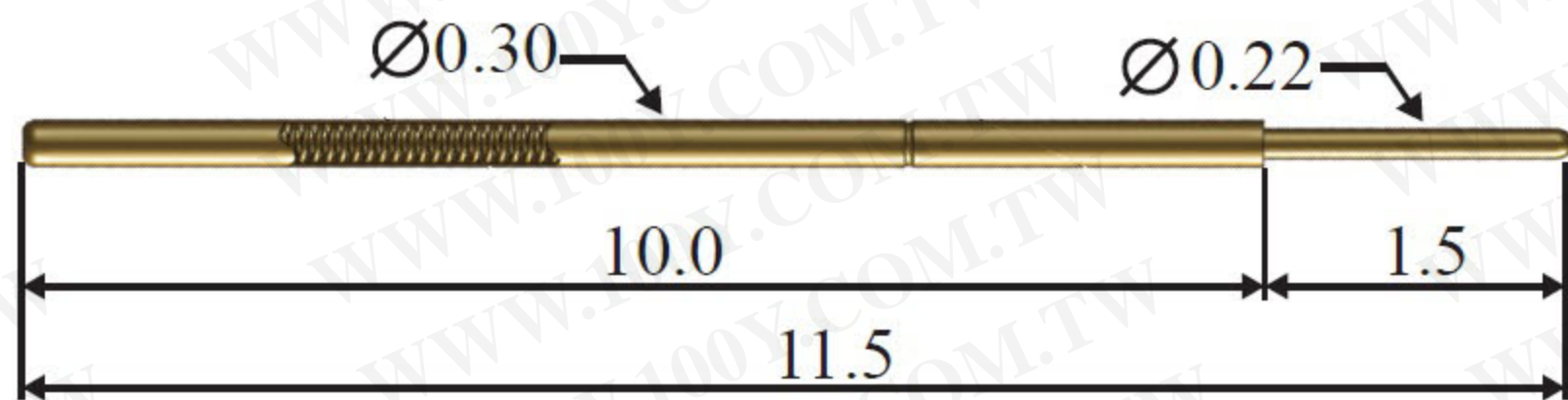

## Timejet TR-030

size:0.35  
unit:mm(inch)

### How to Order (★ Customized)

<b>TJ</b>	<b>-030</b>	<b>02</b>	<b>A</b>	<b>022</b>	<b>020</b>	<b>A</b>
Series	Size	Tip	Tip Plating	Outer	Spring Force	Tube Plating
			A:Gold ★ R:Rh			A:Gold ★ N:Nickel Silver

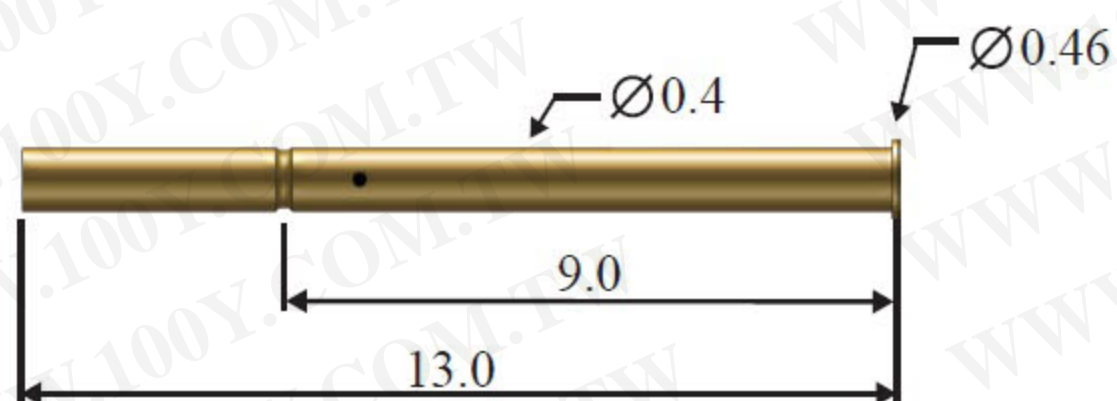

★ TR-030UCC

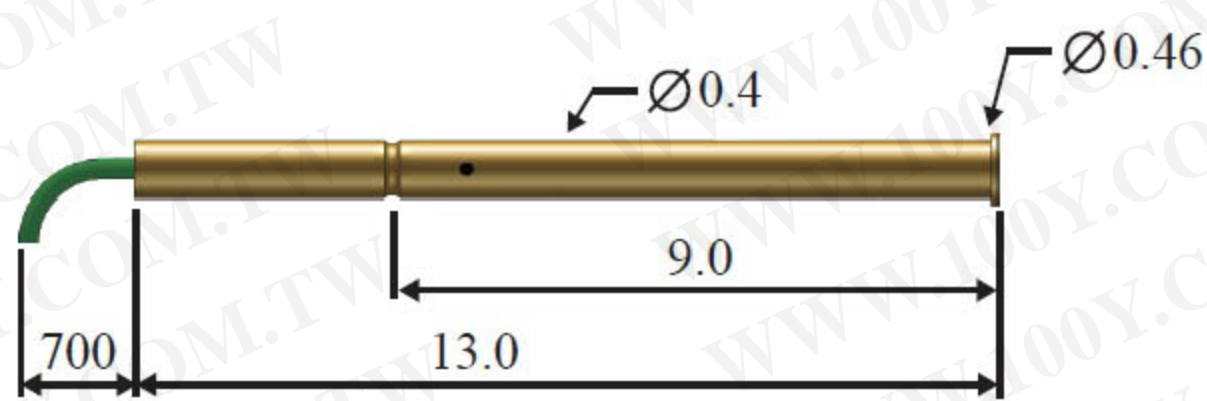

★ TR-030UCW

### How to Order (★ Customized)

<b>TR</b>	<b>-030</b>	<b>UC</b>	<b>C</b>	<b>70</b>
Series	Size	Style	Terminal	Wire-Length
		★ UC:V type No Rings by CNC	C:Crimp W:Wire Wrap	70:700mm

### Material Data

針軸 Plunger  
高碳鋼鍍金 SK4 with Gold Plated  
內管 Barrel  
磷青銅鍍金 Phosphor Bronze with Gold Plated  
彈簧 Spring  
琴鋼線鍍金 Music Wire with Gold Plated  
外管 Receptacle  
黃銅鍍金 Brass with Gold Plated

### Electrical Data

最小中心距 Min. Center  
0.6mm ( 0.0236" )  
建議鑽孔尺寸 Recommended Hole Size  
0.42mm( 0.0165" )  
額定電流 Current Rating  
0.5A( 安培 )  
接觸電阻 Contact Resistance  
200mΩ( 毫歐姆)

### Mechanical Data

工作行程 Working Stroke  
1mm ( 0.0393" )  
最大行程 Maximum Stroke  
1.5mm ( 0.0590" )  
工作行程彈力 Spring Force at Working Stroke  
20g

# TJ-035

size:0.35

unit:mm(inch)

## TJ serie PCB Probe

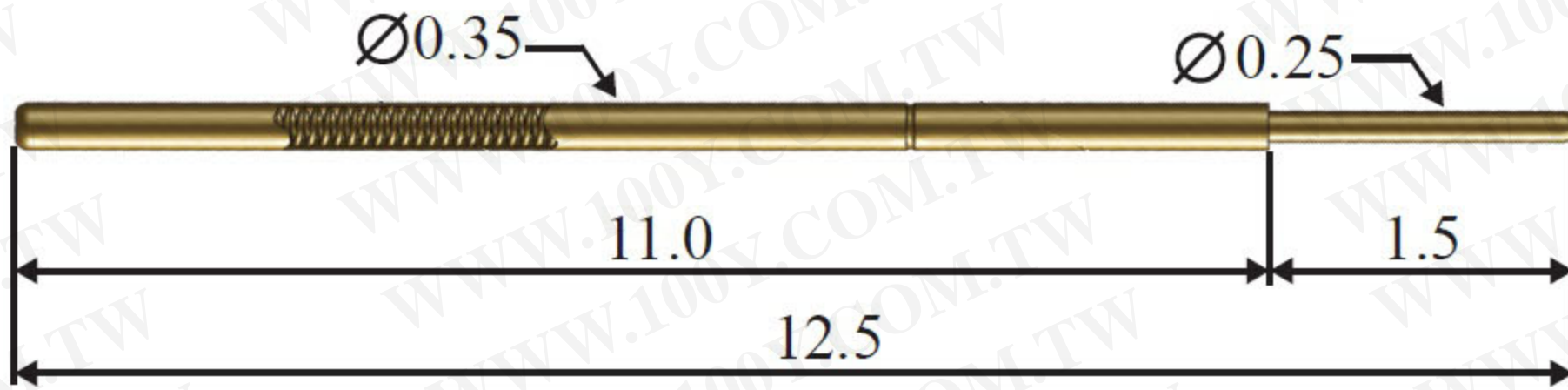

### Plunger Tips

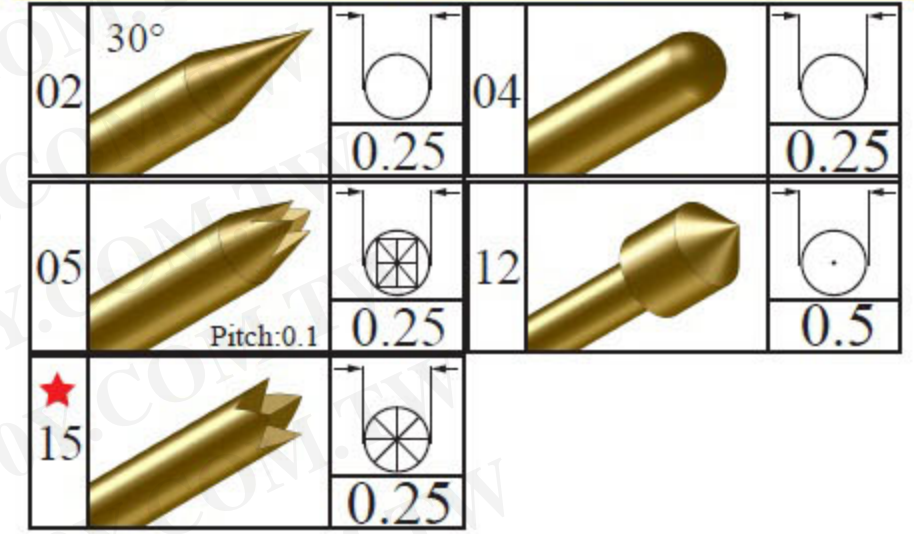

# Timejet TR-035

size:0.45  
unit:mm(inch)

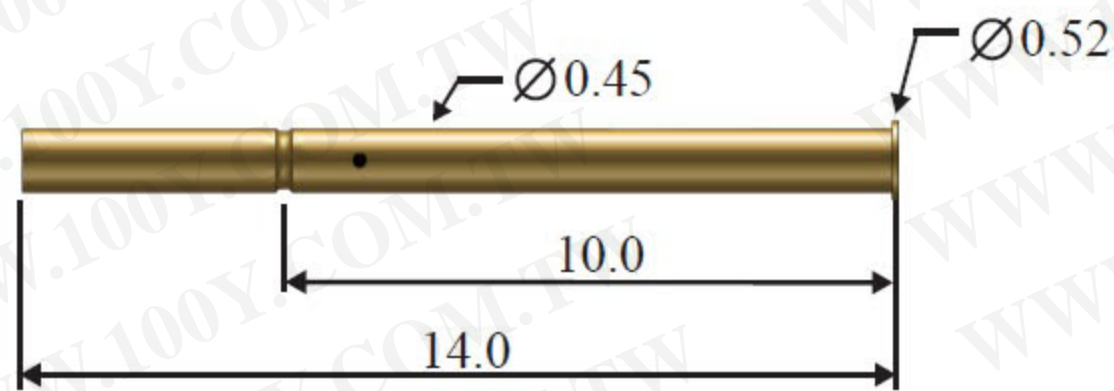

★ TR-035UCC

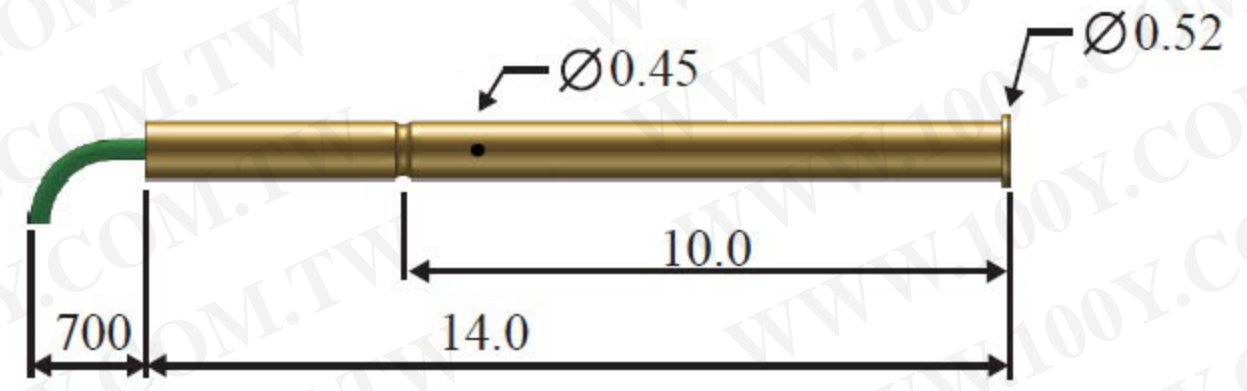

★ TR-035UCW

### How to Order (★ Customized)

<b>TJ</b>	<b>-035</b>	<b>02</b>	<b>A</b>	<b>025</b>	<b>020</b>	<b>A</b>
Series	Size	Tip	Tip Plating	Outer	Spring Force	Tube Plating
			A:Gold ★R:Rh			A:Gold ★N:Nickel Silver

### Material Data

針軸 Plunger  
高碳鋼鍍金 SK4 with Gold Plated  
內管 Barrel  
磷青銅鍍金 Phosphor Bronze with Gold Plated  
彈簧 Spring  
琴鋼線鍍金 Music Wire with Gold Plated  
外管 Receptacle  
黃銅鍍金 Brass with Gold Plated

### Electrical Data

最小中心距 Min. Center  
0.65mm (0.0256")  
建議鑽孔尺寸 Recommended Hole Size  
0.47mm(0.0185")  
額定電流 Current Rating  
0.5A(安培)  
接觸電阻 Contact Resistance  
180mΩ(毫歐姆)

### Mechanical Data

工作行程 Working Stroke  
1mm (0.0393")  
最大行程 Maximum Stroke  
1.5mm (0.0590")  
工作行程彈力 Spring Force at Working Stroke  
20g

### How to Order (★ Customized)

<b>TR</b>	<b>-035</b>	<b>UC</b>	<b>C</b>	<b>70</b>
Series	Size	Style	Terminal	Wire-Length
		★UC:V type No Rings by CNC	C:Crimp W:Wire Wrap	70:700mm

# TJ-038A&B

size:0.38

unit:mm(inch)

# TJ serise PCB Probe

TJ-038A



TJ-038B

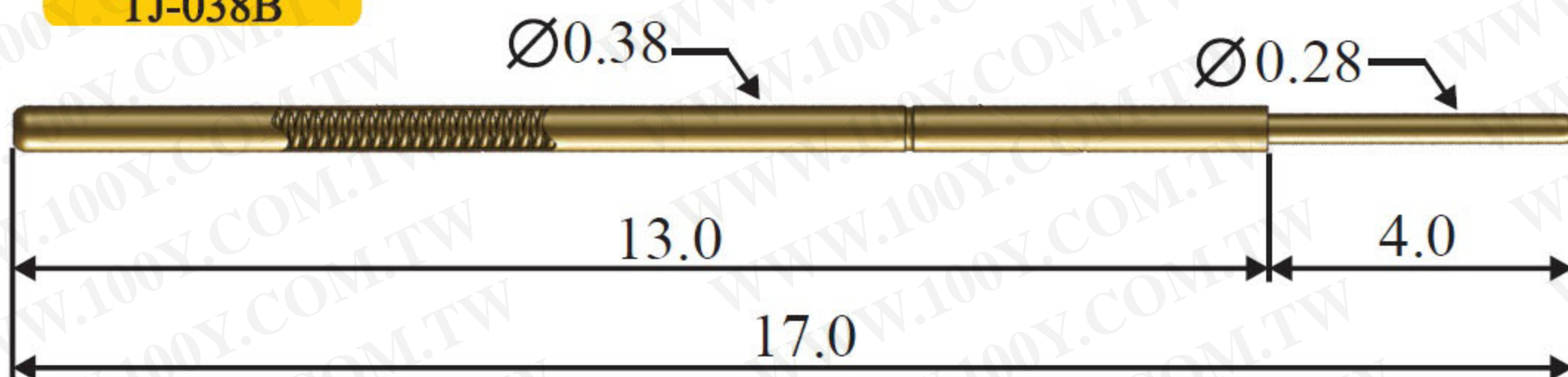

## Plunger Tips

02			04		
05			06		
12			14		
15					

## How to Order (★ Customized)

<b>TJ</b>	<b>-038</b>	<b>A</b>	<b>02</b>	<b>A</b>	<b>028</b>	<b>033</b>	<b>A</b>
Series	Size	Length	Tip	Tip Plating	Outer	Spring Force	Tube Plating
		A		A:Gold			A:Gold
		B	★ R:Rh				★ N:Nickel Silver

# Timejet TR-038A&B

size:0.52  
unit:mm(inch)

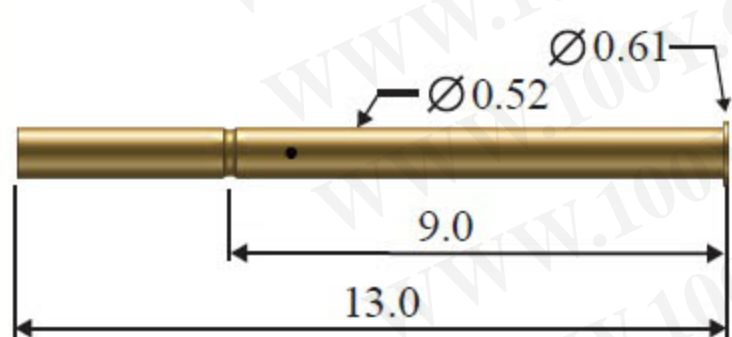

★ TR-038AUCC

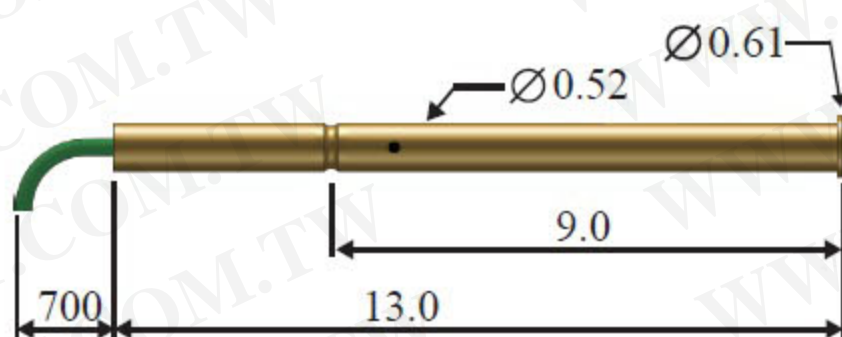

★ TR-038AUCW700

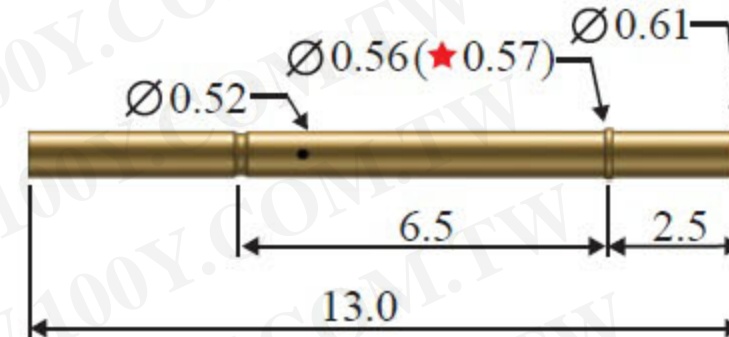

★ TR-038AVC25C

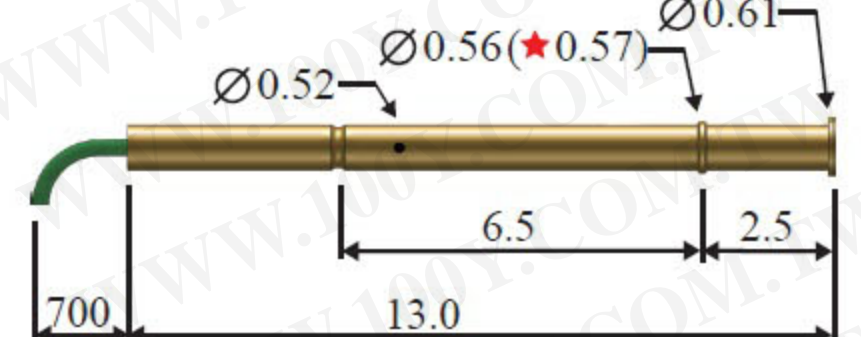

★ TR-038AVC25W700

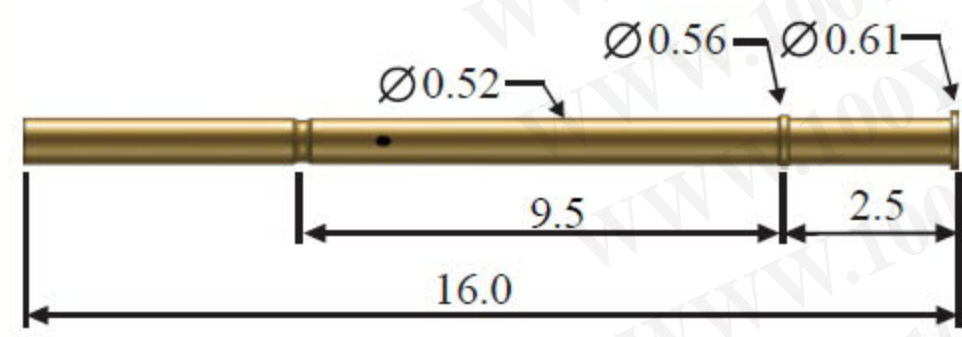

★ TR-038BVC25C



★ TR-038BVC25W700

## How to Order (★ Customized)

<b>TR</b>	<b>-038</b>	<b>A</b>	<b>VC</b>	<b>25</b>	<b>C</b>	<b>70</b>
Series	Size	Length	Style	Distance of Press-Ring	Terminal	Wire-Length
		A	★ UC:V type No Rings by CNC	25:2.5	C:Crimp	70:700mm
		B	★ VC:V type 1 Ring by CNC		W:Wire Wrap	

### Material Data

針軸 Plunger  
高碳鋼鍍金 SK4 with Gold Plated  
內管 Barrel  
磷青銅鍍金 Phosphor Bronze with Gold Plated  
彈簧 Spring  
琴鋼線鍍金 Music Wire with Gold Plated  
外管 Receptacle  
黃銅鍍金 Brass with Gold Plated

### Electrical Data

最小中心距 Min. Center  
0.75mm ( 0.0295" )  
建議鑽孔尺寸 Recommended Hole Size  
0.57mm ( 0.0225" )  
額定電流 Current Rating  
0.5A( 安培 )  
接觸電阻 Contact Resistance  
180mΩ( 毫歐姆)

### Mechanical Data

工作行程 Working Stroke  
A:1mm ( 0.0393" ) , B:2.7mm ( 0.0106" )  
最大行程 Maximum Stroke  
A:1.5mm ( 0.0590" ) , B:4mm ( 0.1574" )  
工作行程彈力 Spring Force at Working Stroke  
33g

# TJ-039L

size:0.61

unit:mm(inch)

# TC serie ICT Probe

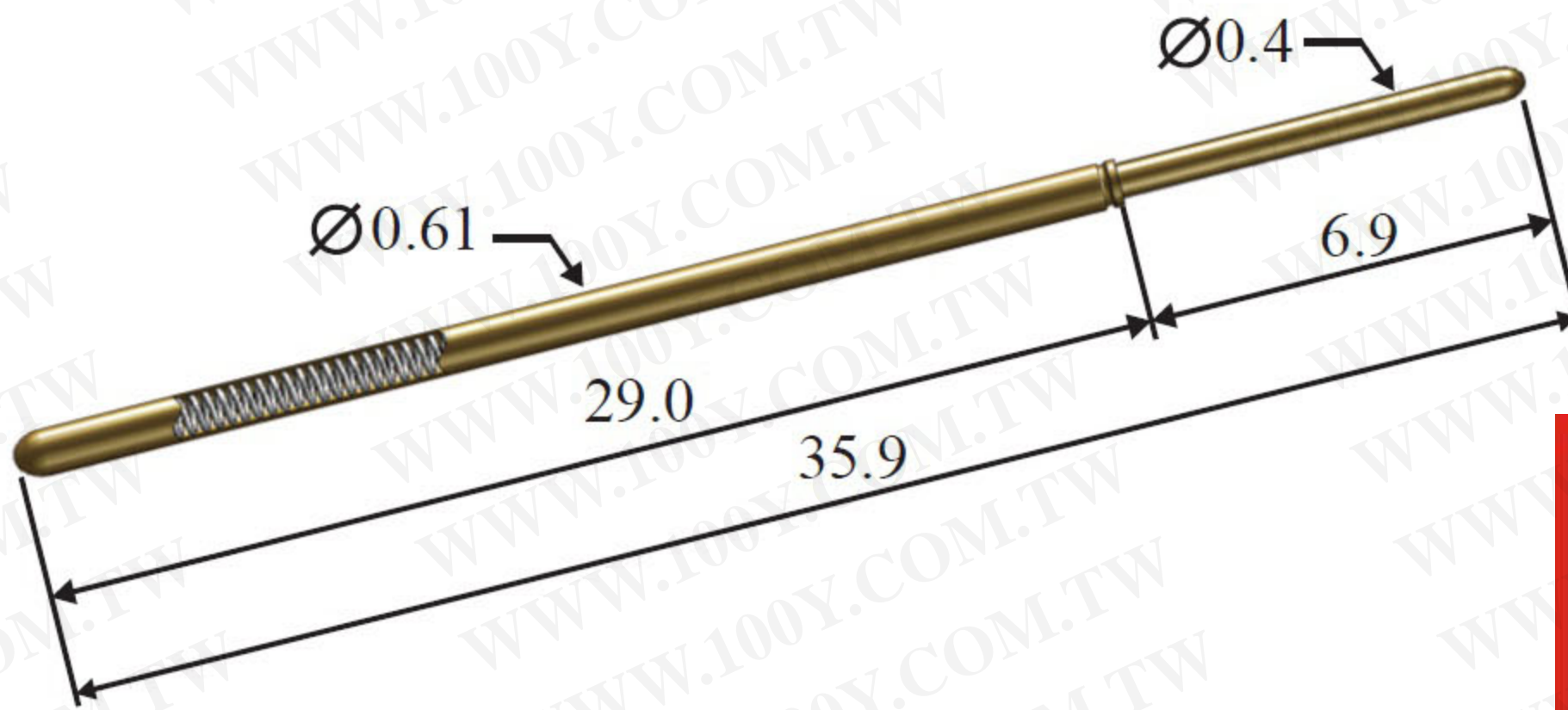

### Plunger Tips

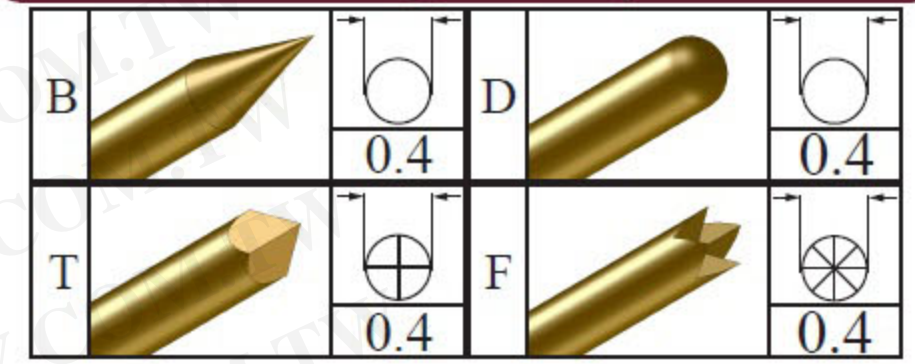

勝特力材料 886-3-5753170  
 勝特力电子(上海) 86-21-54151736  
 勝特力电子(深圳) 86-755-83298787  
[Http://www.100y.com.tw](http://www.100y.com.tw)

# Timejet TK-040

size:0.77  
unit:mm(inch)

### How to Order

<b>TJ-039L</b>	<b>T</b>	<b>A</b>	<b>040</b>	<b>080</b>	<b>A</b>
Series	Size	Tip	Tip Plating	Outer Spring Force	Tube Plating
			A:Gold R:Rh		A:Gold N:Nickel Silver

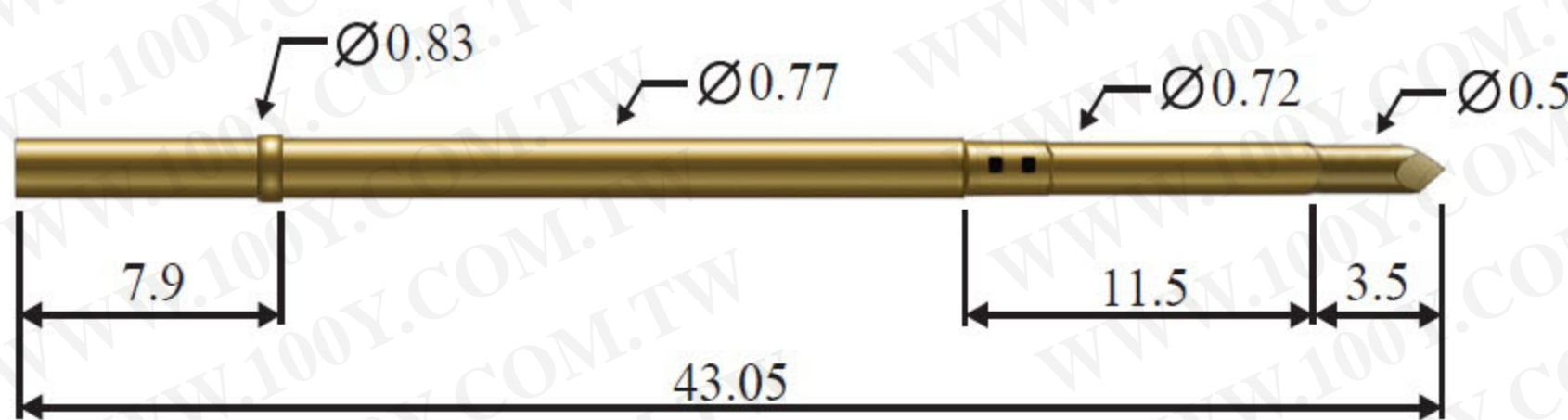

TK-040WL

### How to Order

<b>TK-040</b>	<b>W</b>	<b>79</b>	<b>C</b>	<b>70</b>	<b>28</b>
Series	Size	Style	Terminal	Wire-Length	Wire-Size
		W: Straight type 1 Rings	C: Crimp W: Wire Wrap I: Insertion Wire	60: 600mm 70: 700mm	28 30

### Material Data

針軸 Plunger  
 高碳鋼鍍金 SK4 with Gold Plated  
 內管 Barrel  
 磷銅鍍金 Phosphor Bronze with Gold Plated  
 彈簧 Spring  
 琴鋼線鍍金 Music Wire with Gold Plated  
 外管 Receptacle  
 磷銅鍍金 Phosphor Bronze with Gold Plated

### Electrical Data

最小中心距 Min. Center  
 1.0mm (0.039")  
 建議鑽孔尺寸 Recommended Hole Size  
 0.79mm~0.80mm(0.0311"~0.0315")  
 額定電流 Current Rating  
 2A(安培)  
 接觸電阻 Contact Resistance  
 20mΩ(毫歐姆)

### Mechanical Data

2/3 工作行程 2/3 Working Stroke  
 4.3mm (0.169")  
 2/3 行程彈力 2/3 Spring Force at Stroke  
 80g