

Vinyl Insulated Hook Terminals (V Series)

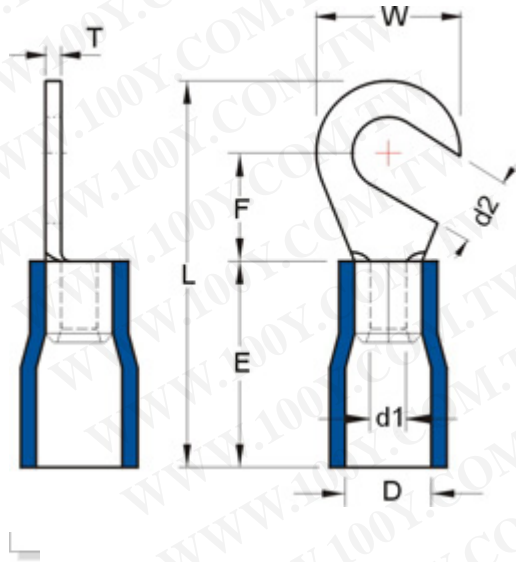

勝特力材料 886-3-5753170
 勝特力电子(上海) 86-21-34970699
 勝特力电子(深圳) 86-755-83298787
[Http://www.100y.com.tw](http://www.100y.com.tw)

MAXIMUM ELECTRIC CURRENT:

A. W. G.	22	20	18	16	14	12	10
AMP.	9	12	17	18	30	35	50

MAXIMUM ELECTRICAL RATING: 105° C 600 VOLTS MAX.

INSULATION MATERIAL: VINYL

INSULATION COLOR:

22-16A. W. G. : RED 16-14A. W. G. : BLUE

12-10A. W. G. : YELLOW

TERMINAL MATERIAL: COPPER

WIRE RANGE A. W. G. mm ²	ITEM NO.		STUD SIZE	DIMENSION inch (mm)							Q' TY BOX	
	BRAZED SEAM	BUTTED SEAM		d2	W	F	L	E	D	d1		T
22-16 A. W. G.	<input type="checkbox"/> HVB1-3.7	<input type="checkbox"/> HV1-3.7	#6	0.146 3.7	0.315 8	0.276 7	0.819 20.8	0.394 10	0.157 4.000	0.067 1.7	0.03 0.75	1000
0.5-1.5	<input type="checkbox"/> HVB1-4	<input type="checkbox"/> HV1-4	#8	0.169 4.3	0.315 8	0.276 7	0.819 20.8	0.394 10	0.157 4.000	0.067 1.7	0.03 0.75	1000

mm ²	<input type="checkbox"/> HVB1-5	<input type="checkbox"/> HV1-5	#10	0.209 5.3	0.315 8	0.276 7	0.819 20.8	0.394 10	0.157 4.000	0.067 1.7	0.03 0.75	1000
	<input type="checkbox"/> HVB1-6	<input type="checkbox"/> HV1-6	1/4	0.252 6.4	0.457 11.6	0.433 11	1.055 26.8	0.394 10	0.157 4.000	0.067 1.7	0.03 0.75	1000
16-14 A. W. G.	<input type="checkbox"/> HVB2-3.7	<input type="checkbox"/> HV2-3.7	#6	0.146 3.7	0.335 8.5	0.291 7.4	0.858 21.8	0.394 10	0.177 4.500	0.091 2.3	0.31 0.8	1000
	<input type="checkbox"/> HVB2-4	<input type="checkbox"/> HV2-4	#8	0.169 4.3	0.335 8.5	0.291 7.4	0.858 21.8	0.394 10	0.177 4.500	0.091 2.3	0.31 0.8	1000
1.5-2.5 mm ²	<input type="checkbox"/> HVB2-5	<input type="checkbox"/> HV2-5	#10	0.209 5.3	0.374 9.5	0.287 7.3	0.858 21.8	0.394 10	0.177 4.500	0.091 2.3	0.31 0.8	1000
	<input type="checkbox"/> HVB2-6	<input type="checkbox"/> HV2-6	1/4	0.252 6.4	0.472 12	0.433 11	1.055 26.8	0.394 10	0.177 4.500	0.091 2.3	0.31 0.8	1000
12-10 A. W. G.	<input type="checkbox"/> HVB5-3.7	<input type="checkbox"/> HV5-3.7	#6	0.146 3.7	0.283 7.2	0.24 6.1	0.894 22.7	0.512 13	0.252 6.400	0.134 3.4	0.039 1	500
	<input type="checkbox"/> HVB5-4	<input type="checkbox"/> HV5-4	#8	0.169 4.3	0.374 9.5	0.374 9.5	1.055 26.8	0.512 13	0.252 6.400	0.134 3.4	0.039 1	500
4-6 mm ²	<input type="checkbox"/> HVB5-5	<input type="checkbox"/> HV5-5	#10	0.209 5.3	0.374 9.5	0.374 9.5	1.005 26.8	0.512 13	0.252 6.400	0.134 3.4	0.039 1	500
	<input type="checkbox"/> HVB5-6	<input type="checkbox"/> HV5-6	1/4	0.252 6.4	0.472 12	0.406 10.3	1.161 29.5	0.512 13	0.252 6.400	0.134 3.4	0.039 1	500
	<input type="checkbox"/> HVB5-8	<input type="checkbox"/> HV5-8	5/16	0.331 8.4	0.591 15	0.531 13.5	1.339 34	0.512 13	0.252 6.400	0.134 3.4	0.039 1	500