

P/N C012-OXX

REV.	DESCRIPTION	ECN.(DO)	APPD.
K	CHANGE	E031110H205	Robbie
L	Change the plated thickness	H0101	Robbie
M	CHANGE THE DRAWING FRAME	H1009	Robbie
N	ADD "ROHS" winnie 09/10/07'	H2469	Ray
O	ADD NEW P/N Colin 07/04/11'	H4685	Ray

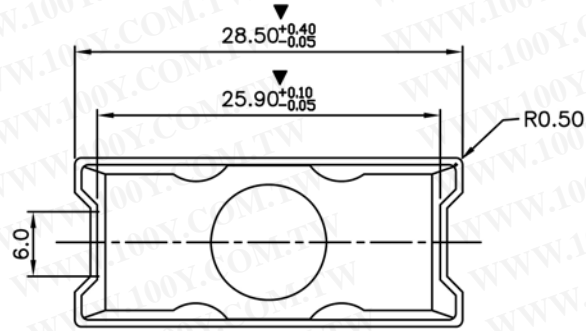

勝特力材料 886-3-5753170  
 勝特力电子(上海) 86-21-34970699  
 勝特力电子(深圳) 86-755-83298787  
[Http://www.100y.com.tw](http://www.100y.com.tw)

NOTE :

1. MATERIAL : SPCC (Fe)
2. THICKNESS : 0.50±0.05m/m
3. FINISH : Cu : 80u"~100u" ,  
PURE Tin : 100u"~120u"
4. ▼ DENOTES INSPECTION CRITERIA LINE NO.

PART NUMBER:

P\N	(A)DIM	(B)DIM
C012-010	∅6.0	∅11.75
C012-001	∅6.5	∅11.75
C012-002	∅7.0	∅11.75
C012-003	∅7.5	∅11.75
C012-004	∅8.0	∅11.75
C012-005	∅8.5	∅11.75
C012-006	∅9.0	∅11.75
C012-007	∅9.5	∅11.75
C012-008	∅10.0	∅11.75
C012-009	∅11.0	∅12.1
C012-011	∅12.0	∅13.1

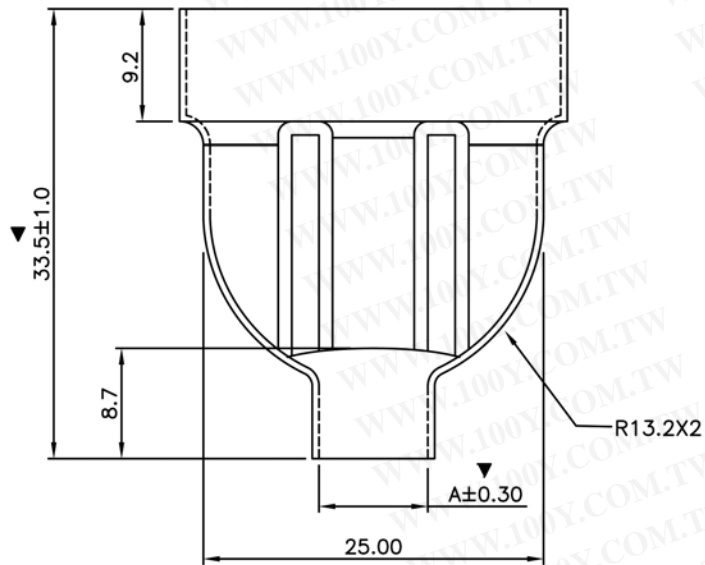

A-A

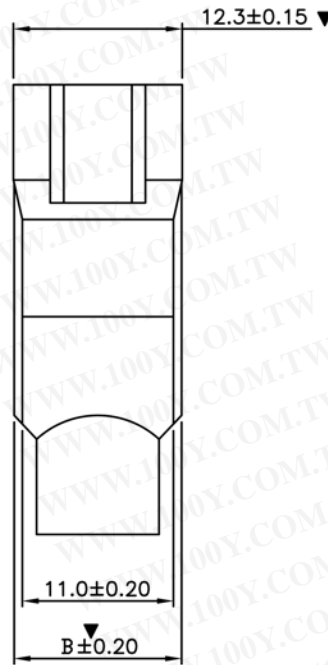

MILLIMETERS	INCH	UNITS	MM	NAME(INTENDED USE)					
X.± 2'	X.± 2'	MAT'L		DVI					
.X± 0.25	.X± .010				PART NO.(INTENDED USE)	TITLE			
.XX± 0.13	.XX± .005	FINISH		C012-OXX	DVI UNITY TYPE TIN (ROHS)				
.XXX± ----	.XXX± ----				APPD: Robbie lou06/01/05'	DWG NO.			
THESE DRAWINGS AND SPECIFICATIONS ARE THE PROPERTY OF CIRCUIT ASSEMBLY SHEN ZHEN AND SHALL NOT BE REPRODUCED, COPIED OR USED IN ANY MANNER WITHOUT THE PRIOR WRITTEN CONSENT OF CIRCUIT ASSEMBLY SHEN ZHEN				Q'TY	CHKD Eric Yan05/31/05'	H012102			
				DR: Colin Liu 05/30/05'			SCALE	SHEET	REV.
							1/1	1/1	0

A  
B  
C  
D  
E

A  
B  
C  
D  
E