

Type III+
Contacts

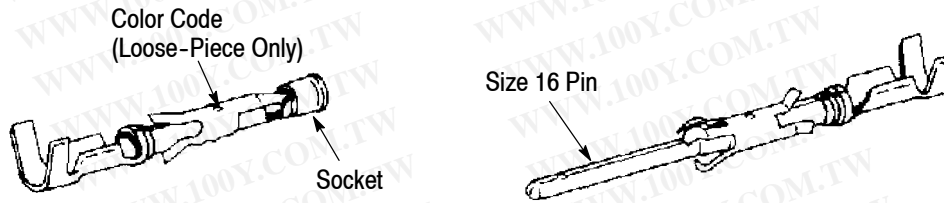

WIRE		TYPE III+ CONTACTS					COLOR DOT	HAND CRIMPING TOOL (Instruction Sheet Reference for Crimping Procedures)
SIZE (AWG)	INSUL DIA	CONT SIZE	LOOSE PIECE		STRIP			
			PIN	SOCKET	PIN	SOCKET		
30 to 26	0.36-0.76 [.014-.030]	16	66406	66405	66393	66394	Brown	90225-2 (408-7414)
	1.02-1.52 [.040-.060]		66429	66428	66425	66424		—
26 to 24	0.89-1.40 [.035-.055]		66107	66109	66106	66108		58495-1 (408-9819) ■ 90066-7 (408-6610)
24 to 20	1.02-2.03 [.040-.080]		66103	66105	66102	66104	58495-1 (408-9819) ■ 90067-4 (408-6613)	
24 to 20	2.03-2.54 [.080-.100]		66400	66399	66332	66331	Yellow	90225-2 (408-7414) 90067-5 (408-6614)
	1.52-3.05 [.060-.120]†		66566	66565	66564	66563		90331-1 (408-7773)
18 to 16	2.03-2.54 [.080-.100]		66099	66101	66098	66100	Blue	90067-4 (408-6613) 90067-5 (408-6614) 90310-3 (408-9387) 58495-1 (408-9819) ■
18 to 14	2.03-3.81 [.080-.150]†		66602	66601	66597	66598	—	90310-2 (408-7942)
	2.03-2.54 [.080-.100]		66361	66360	66359	66358	Violet	90067-4 (408-6613) 90310-3 (408-9387)

■ Economy hand tool for field repair only.

† Restricted housing use. Consult your local Tyco Electronics Representative for details.

NOTE: Consult your local Tyco Electronics Representative for assistance in selection of machines and applicators that best suits your needs.

Figure 1

1. INTRODUCTION

This instruction sheet provides the recommended procedures for selecting the proper Type III+, Type II, Type VI, and Subminiature COAXICON* Contacts for use in "G" and "M" Series Connectors; Circular Plastic Connectors (CPC); Metrimate Connectors; and Econoseal Connectors.

Read these instructions thoroughly to make certain the selected contacts are compatible with the specified connector type, and the selected wire and application tooling are compatible with the contacts.

Reasons for reissue of this instruction sheet are provided in Section 7, REVISION SUMMARY.

2. CONTACT DESCRIPTION

2.1. Type III+ (Figure 1)

Pin and socket contacts are available in size 16 (.062-in. pin diameter). On loose-piece contacts, a color dot appears on the contact spring which designates the applicable wire size and matches the color dot above the hand tool crimping section.

Loose-piece contacts are designed for hand tool applications. Continuous strip-form contacts are designed for automatic or semi-automatic machine applications.

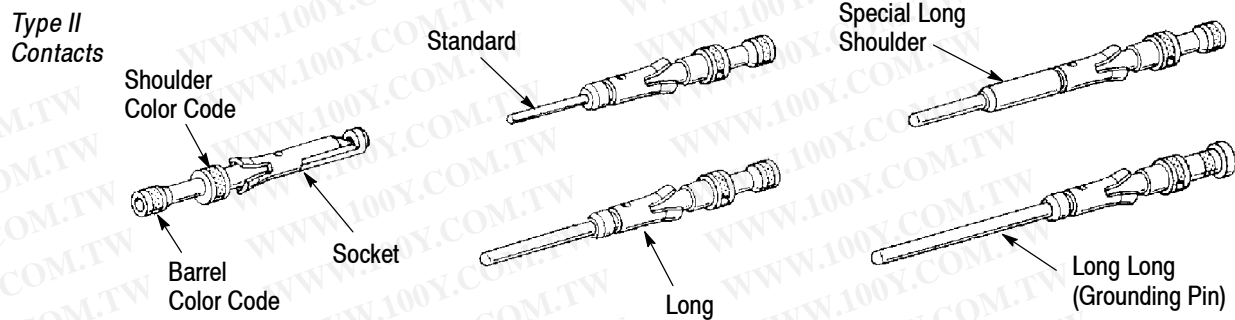

WIRE		TYPE II CONTACTS				COLOR BAND		HAND CRIMPING TOOL	CRIMPING DIES FOR	
SIZE (AWG)	INSUL DIA	SIZE	PIN LENGTH	PIN	SOCKET	BARREL	SHD		PNEU TOOLS (408-7420)	AMP-TAPETRONIC* MACH 69875 (409-1993)
28 to 24	0.89-1.40 [.035-.055]	20	Standard	201607	201609	Red	Red	58305-1 601967-1	90230-1	90249-2
24 to 20	1.02-1.57 [.040-.062]			201582	201584	Yellow		58305-1 58541-1 601967-1		
	1.40-1.91 [.055-.075]			200334	200331		45098 58541-1 601967-1			
18 to 16	No Insul Barrel	—	201589	Blue	Blue	90231-2	90250-1			
32 to 30	0.76-1.22 [.030-.048]	16	Long	201555	201554	White	Red	58305-1	90230-1	—
28 to 24	0.89-1.40 [.035-.055]		Long	201611	201613	Red		58305-1 601967-1		
	1.22-1.65 [.048-.065]		201334	201332						
24 to 20	1.02-1.57 [.040-.062]	Long	201578	201580	Yellow	Red	58305-1 58541-1	90230-1	90249-2	
	1.40-2.16 [.055-.085]	Standard	200679	201328			58305-1 58541-1 601967-1			
		Long	201330				58305-1 58541-1			
		Sp Long	204188				58305-1 58541-1			
(2) 18	No Insul Barrel	Long	202725	202726	—	Blue	45098 58541-1	90231-2	90250-1	
18 to 16		Standard	—	200333	Blue		45098 58541-1 601967-1			
		200681	45098 58541-1							
		Long	200336				45098 58541-1 601967-1			
		Sp Long	204274				45098 58541-1			
14		No Insul Barrel	L Long	204219	—		—			45098
	Long		202507	202508	—	—	90136-1	—		
	Long		201570	201568	Violet	Blue	45098 58541-1	90231-2	90250-1	
Standard	201645	201568								
Long Long	212618-1	—	—	—	—	—	—			

■ Refer to the following instruction sheet numbers for specific crimping procedures - for Hand Tools 58305-1 and 45098 (408-1786), 58541-1 (408-4051), 601967-1 (408-7516), and 90136-1 (408-7267).

■ Use Turret 1-601967-5 on 601967-1 for pins. Use Turret 1-601967-6 on 601967-1 for sockets.

NOTE: Hand Tool 58541-1 is for field use only.

Figure 2

2.2. Type II (Figure 2)

Pin and socket contacts are available in size 20 (.040-in. pin diameter), and size 16 (.062-in. pin diameter). There are four pin lengths – standard, long, long-long (grounding pin), and special long shoulder. Mating socket contacts accept all pin lengths. Two color bands appear on each contact.

The shoulder color band identifies the applicable tooling by matching the colored handles of the hand tool or colored holding screws of the die assembly. The insulation barrel or wire barrel color band designates the applicable wire size and matches the color dot above the crimping section on the hand tool or die assembly.

Loose-piece contacts are designed for hand tool or pneumatic tool applications. Tape-mounted contacts are designed for pneumatic tool or semi-automatic machine applications.

2.3. Type VI (Figure 3)

Pin and socket contacts are available in a size 16 (.062-in. pin diameter) only. A wire size marking appears on the underside of each contact insulation barrel. This marking designates the applicable wire size and matches the wire size marking above the hand tool crimping section.

Loose-piece contacts are designed for hand tool applications. Continuous strip-form contacts are designed for automatic or semi-automatic machine applications.

2.4. Subminiature COAXICON Contacts (Figure 4)

Pin contacts are available in a short length, a long length, and a medium length (Multimate pin). Mating socket contacts accept all pin lengths.

Loose-piece contacts are designed for hand tool and pneumatic tool applications. Consult your local Tyco Electronics Representative concerning tooling for continuous strip-form contacts.

3. CONNECTORS

Determine the connector type to be assembled. Refer to the listing of compatible contacts under the appropriate connector heading and select the desired contact type and recommended size.

3.1. “M” Series Shallow Mating (M-SM) Connectors

These connectors accept the following pin contacts only:

Type II – Sizes 20 and 16 (standard length) from Figure 2.

Subminiature COAXICON Contacts – Short pins from Figure 4.

Type VI Contacts

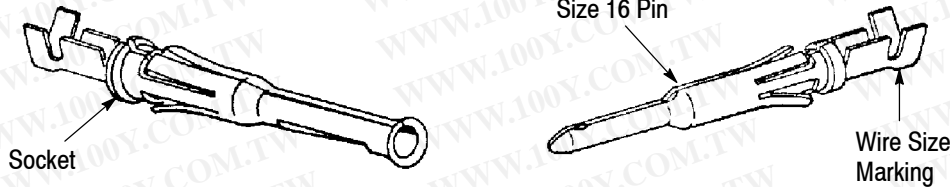

WIRE		CONT SIZE	TYPE VI CONTACTS				HAND CRIMPING TOOL (Instruction Sheet Reference for Crimping Procedures)
SIZE (AWG)	INSUL DIA		LOOSE PIECE		STRIP		
			PIN	SOCKET	PIN	SOCKET	
28 to 24	0.89-1.40 [.035-.055]	16	—	—	66585	66586	90066-7 (408-6610) 58495-1 (408-9819) ■
24 to 20	1.02-2.03 [.040-.080]		66593	66594	66583	66584	90067-4 (408-6613) 90067-7 (408-6610) 58495-1 (408-9819) ■
22 to 18	1.27-2.79 [.050-.110]		66591	66592	66581	66582	90327-1 (408-7716)
18 to 16	2.03-2.54 [.080-.100]		66589	66590	66579	66580	90067-4 (408-6613) 90310-3 (408-9387) 58495-1 (408-9819) ■
18 to 14	2.03-3.43 [.080-.135]		66587	66588	66577	66578	90310-1 (408-7680)

■ Economy hand tool for field repair only.

NOTE: Consult your local Tyco Electronics Representative for assistance in selection of machines and applicators that best suits your needs.

Figure 3

Subminiature
COAXICON
Contacts

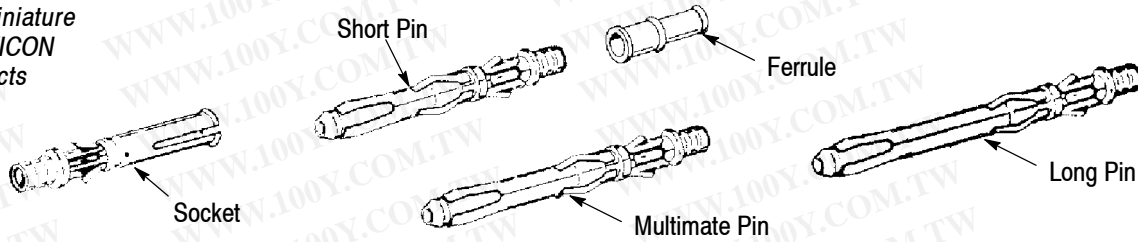

CABLE SIZE	SUBMINIATURE COAXICON CONTACTS				FERRULE	HAND CRIMPING TOOL (408-2024-2)	CRIMPING DIES** (408-2024-3)
	MULTIMATE PIN (Loose Piece)	LONG PIN (Loose Piece)	SHORT PIN (Loose Piece)	SOCKET (Loose Piece)			
RG-174, 188, 316	226537-1	226537-1 226537-4	51563-1	51565-1 51565-4	1-332056-0	69656	69690
RG-174 Double Braid					225088-3	69656-7	—
RG-179, 187					1-322056-0	69656-1	69690-1
RG-187 Double Braid					225088-1	69656-8	—
RG-161					1-332056-0	—	—
26 AWG Shielded .075 Max OD	226537-2	226537-2	51563-2	51565-2 51565-5	1-332057-0	69656-3	69690-3
RG-178, 196					1-332057-0	69656-2	69690-2
RG-196 Double Braid	226537-3	226537-3	51563-3	51565-3	225088-1	69656-9	—
26 AWG Tw Pr Solid or 7 Str .0063 Dia					1-332057-0	69656	69690
28 AWG Tw Pr Solid						69656-1 or 69656-2	69690-1 or 69690-2
28 AWG Tw Pr 7 Str .005 Dia							
30 AWG Tw Pr Solid	69656-2	69690-2					

** Used with Hand Crimping Tool 69710-1 (408-2095).

Figure 4

3.2. “M” Series Deep Mating (M-DM), “G” Series, CPC, Metrimate, and Econoseal Connectors

These connectors accept the following pin and mating socket contacts:

Type II – Size 16 (long, grounding pin, and special long shoulder length) from Figure 2.

Type III+ – size 16 from Figure 1.

Type VI – Size 16 from Figure 3.

Subminiature COAXICON Contacts – Multimater and long pins from Figure 4.

4. CONTACT SELECTION

4.1. Type III+ (Figure 1)

1. Locate appropriate contact size in column 3 as determined by Section 3, CONNECTORS.

2. Determine wire size to be used (column 1). Make certain wire insulation diameter is within range specified in column 2.

3. Columns 4, 5, 6, and 7 indicate appropriate loose-piece and strip-form pin and socket contacts for selected wire size. Check that these contact base part numbers correspond with those on package or reel.

4. A color dot which appears on contact spring is referenced in column 8.

4.2. Type II (Figure 2)

1. Locate appropriate contact size and pin length in columns 3 and 4, as determined by Section 3, CONNECTORS.
2. Determine wire size to be used (column 1). Make certain wire insulation diameter is within range specified in column 2.
3. Columns 5 and 6 indicate appropriate pin and socket contact for selected wire size. Check that these base part numbers correspond with those on package or reel.
4. Color bands which appear on contact shoulder and barrel are referenced in columns 7 and 8.

4.3. Type VI (Figure 3)

1. Determine wire size to be used (column 1). Make certain wire insulation diameter is within range specified in column 2.
2. Columns 4, 5, 6, and 7 indicate appropriate loose-piece and strip-form pin and socket contacts for selected wire size. Check that these contact base part numbers correspond with those on package or reel.

4.4. Subminiature COAXICON Contacts (Figure 4)

1. Determine cable size to be used (column 1).
2. Locate appropriate pin length (multimate, long, or short) in chart heading, as determined by Section 3, CONNECTORS.
3. Columns 2 through 9 indicate appropriate strip-form and loose-piece (LP) pin and socket

contacts for selected cable size. Check that these contact part numbers correspond with those on package or reel.

5. CONTACT INSERTION

Insertion Tools 91002 and 200893 are recommended for inserting Type II, Type III+, and Type VI contacts if wire bundle is large or if wire is fragile.

Refer to Instruction Sheet 408-1817 (packaged with tool 200893) or 408-7347 (packaged with tool 91002), for proper insertion procedures.

To insert a contact, grip wire insulation directly behind contact insulation barrel. Align contact with BACK of desired cavity. Insert contact straight into cavity until it bottoms. Pull back lightly on wire to be sure contact is locked in place.

6. CONTACT EXTRACTION

Extraction Tool 305183 is recommended for extracting Type II, Type III+, Type VI, and Subminiature COAXICON pin and socket contacts from their connectors.

Refer to Instruction Sheet 408-1216 (packaged with tool 305183), for proper extraction procedures.

7. REVISION SUMMARY

Since the previous release of this sheet, the following changes were made:

- Updated document to incorporate requirements

勝特力材料 886-3-5753170
 勝特力电子(上海) 86-21-34970699
 勝特力电子(深圳) 86-755-83298787
[Http://www.100y.com.tw](http://www.100y.com.tw)

THIS DRAWING IS UNPUBLISHED. RELEASED FOR PUBLICATION
 © COPYRIGHT - By - ALL RIGHTS RESERVED.

LOC		DIST		REVISIONS			
P	LTR	DESCRIPTION		DATE	DWN	APVD	
FT	47	F1	REVISED PER ECO-11-004820		11MAR11	RK	HMR

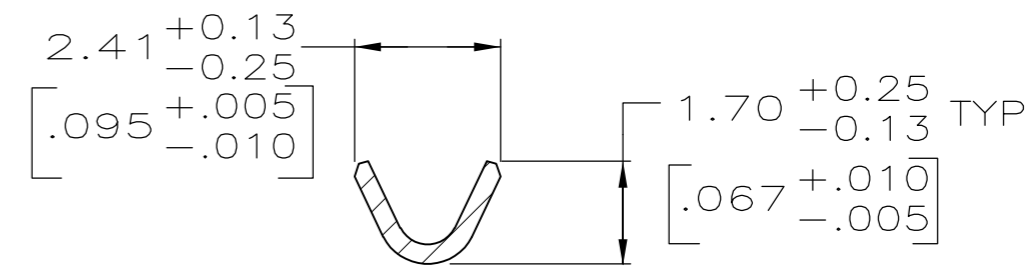
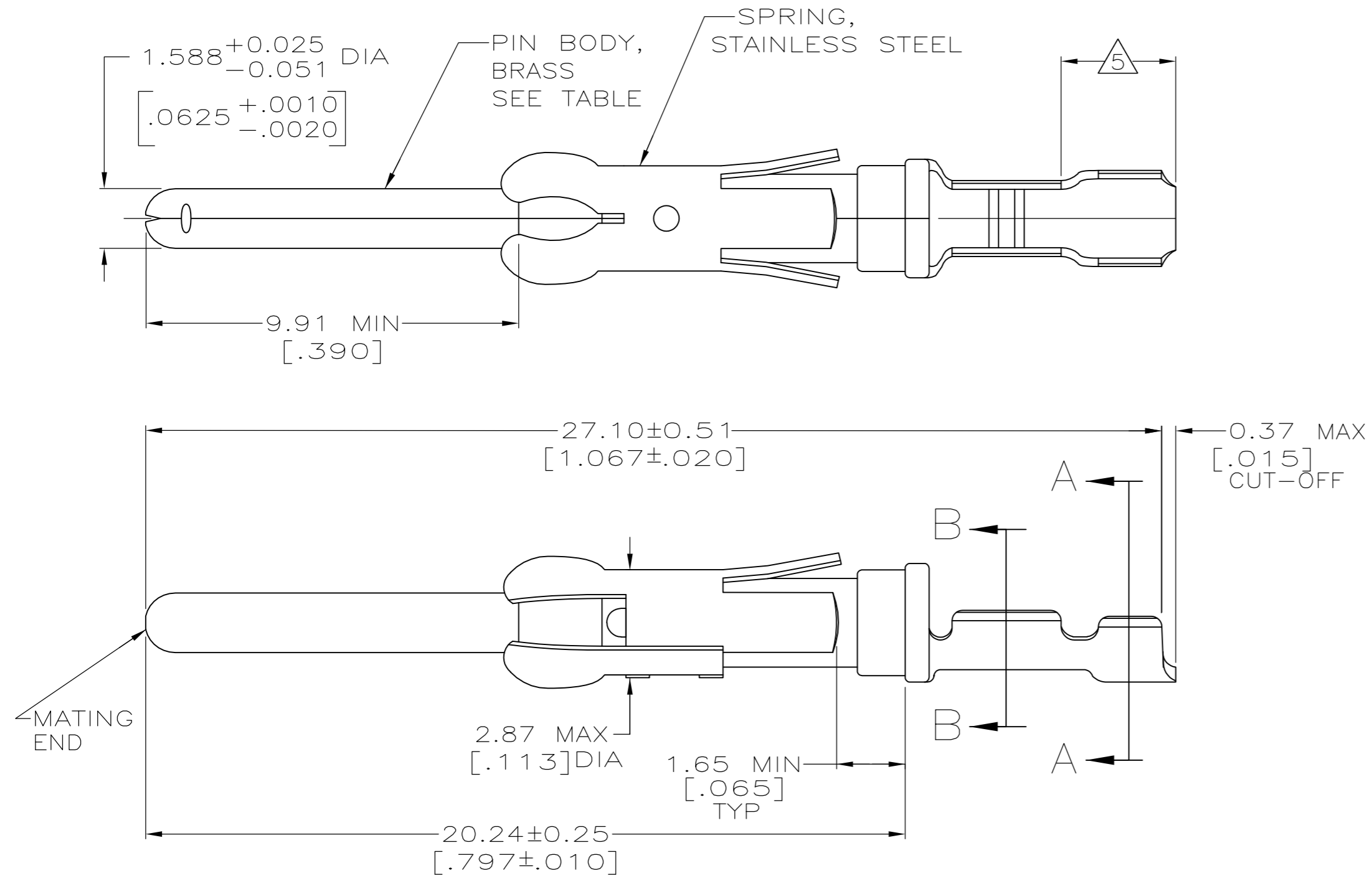

SECTION A-A

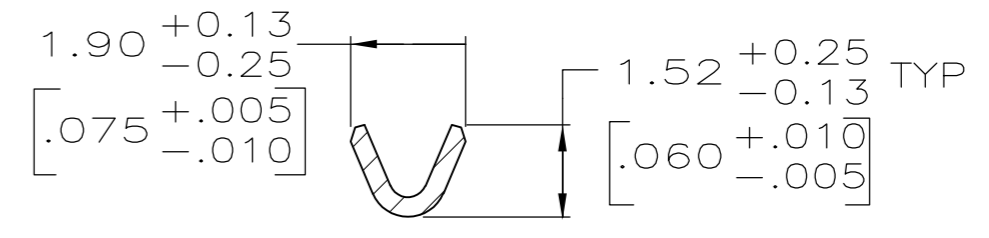

SECTION B-B

- ① 0.76 μm [.000030] MIN PRECIOUS METAL PLATE ON MATING END FOR A LENGTH OF 5.08 [.200] MIN OVER 1.27 μm [.000050] MIN NICKEL PLATE. GOLD FLASH ALL OVER. CONFORMS TO THE REQUIREMENTS OF TE CONNECTIVITY PRODUCT SPEC 108-10042, BASED ON EIA/ECA-364-1000.01A (CONTROLLED ENVIRONMENT APPLICATIONS).
- ② 0.76 μm [.000030] MIN PRECIOUS METAL PLATE ON MATING END FOR A LENGTH OF 5.08 [.200] MIN WITH A UNIFORM GRADIENT TO 0.25 μm [.000010] ON REMAINDER, OVER 1.27 μm [.000050] MIN NICKEL PLATE. GOLD FLASH ALL OVER. CONFORMS TO THE REQUIREMENTS OF TE CONNECTIVITY PRODUCT SPEC 108-10042, BASED ON EIA/ECA-364-1000.01A (CONTROLLED ENVIRONMENT APPLICATIONS).
- ③ 0.38 μm [.000015] MIN GOLD PER MIL-G-45204 ON MATING END FOR A LENGTH OF 5.08 [.200] MIN WITH GOLD FLASH ON THE REMAINDER OVER 1.27 μm [.000050] MIN NICKEL PER QQ-N-290.
- ④ 1.27 μm [.000050] MIN GOLD PER MIL-G-45204 ON MATING END FOR A LENGTH OF 5.08 [.200] MIN WITH GOLD FLASH ON THE REMAINDER OVER 1.90 μm [.000075] MIN NICKEL PER QQ-N-290.
- ⑤ GOLD PLATING NOT REQUIRED IN THIS AREA.
- ⑥ 1.27 μm [.000050] MIN TIN-LEAD PER MIL-T-10727 OVER 1.27 μm [.000050] MIN NICKEL PER QQ-N-290.
- 7. WIRE RANGE 26-24 AWG.
- 8. INSULATION RANGE 0.89 [.035]-1.40 [.055] DIA.
- ⑨ 0.38 μm [.000015] MIN GOLD PER MIL-G-45204 ON MATING END FOR A LENGTH OF 5.08 [.200] MIN, 1.27 μm [.000050] MIN TIN-LEAD PER MIL-T-10727 FOR A LENGTH OF 5.69 [.224] MIN ON OPPOSITE END, BOTH OVER 1.27 μm [.000050] MIN NICKEL PER QQ-N-290 ON ENTIRE CONTACT.
- ⑩ 1.27 μm [.000050] MIN TIN PER MIL-T-10727 OVER 1.27 μm [.000050] MIN NICKEL PER QQ-N-290.

	SMALL PACK	⑩	1-66107-1	1-66107-2
	STANDARD	⑩	1-66106-5	1-66107-1
	SMALL PACK	①	66106-4	1-66107-0
	SMALL PACK	⑥	66106-2	66107-9
OBSOLETE	STANDARD	⑨	1-66106-4	66107-8
OBSOLETE	STANDARD	④	1-66106-2	66107-7
	STANDARD	①	66106-4	66107-4
	STANDARD	③	66106-3	66107-3
	STANDARD	⑥	66106-2	66107-2
	STANDARD	②	66106-1	66107-1
	PACKAGING TYPE	PIN BODY FINISH	STRIP P/N REF	PART NO

THIS DRAWING IS A CONTROLLED DOCUMENT.		DWN	06/02/92		
DIMENSIONS: mm [INCHES]		L.SIPE	6-11-92		
TOLERANCES UNLESS OTHERWISE SPECIFIED:		CHK	W.LENKER		
0 PLC ± -		APVD	G.STEINHAUER		
1 PLC ± -		PRODUCT SPEC		NAME	
2 PLC ± 0.13 [.005]		APPLICATION SPEC		PIN ASSEMBLY, LOOSE PIECE, TYPE III+	
3 PLC ± -				SIZE	CAGE CODE
4 PLC ± -				A2	00779
ANGLES ± -				DRAWING NO	RESTRICTED TO
FINISH		WEIGHT	-	C=66107	-
SEE CALLOUTS		CUSTOMER DRAWING		SCALE	SHEET
				8:1	1 of 1
				REV	F1