

THIS DRAWING IS UNPUBLISHED. RELEASED FOR PUBLICATION
 © COPYRIGHT - By - ALL RIGHTS RESERVED.

LOC	DIST	REVISIONS			
P	LTR	DESCRIPTION	DATE	DWN	APVD
BD	35	H1	REVISED PER ECO-11-004917	11MAR11	RK HMR

勝特力電材超市-龍山店 886-3-5773766
 勝特力電材超市-光復店 886-3-5729570
 勝特力电子(上海) 86-21-34970699
 勝特力电子(深圳) 86-755-83298787
<http://www.100y.com.tw>

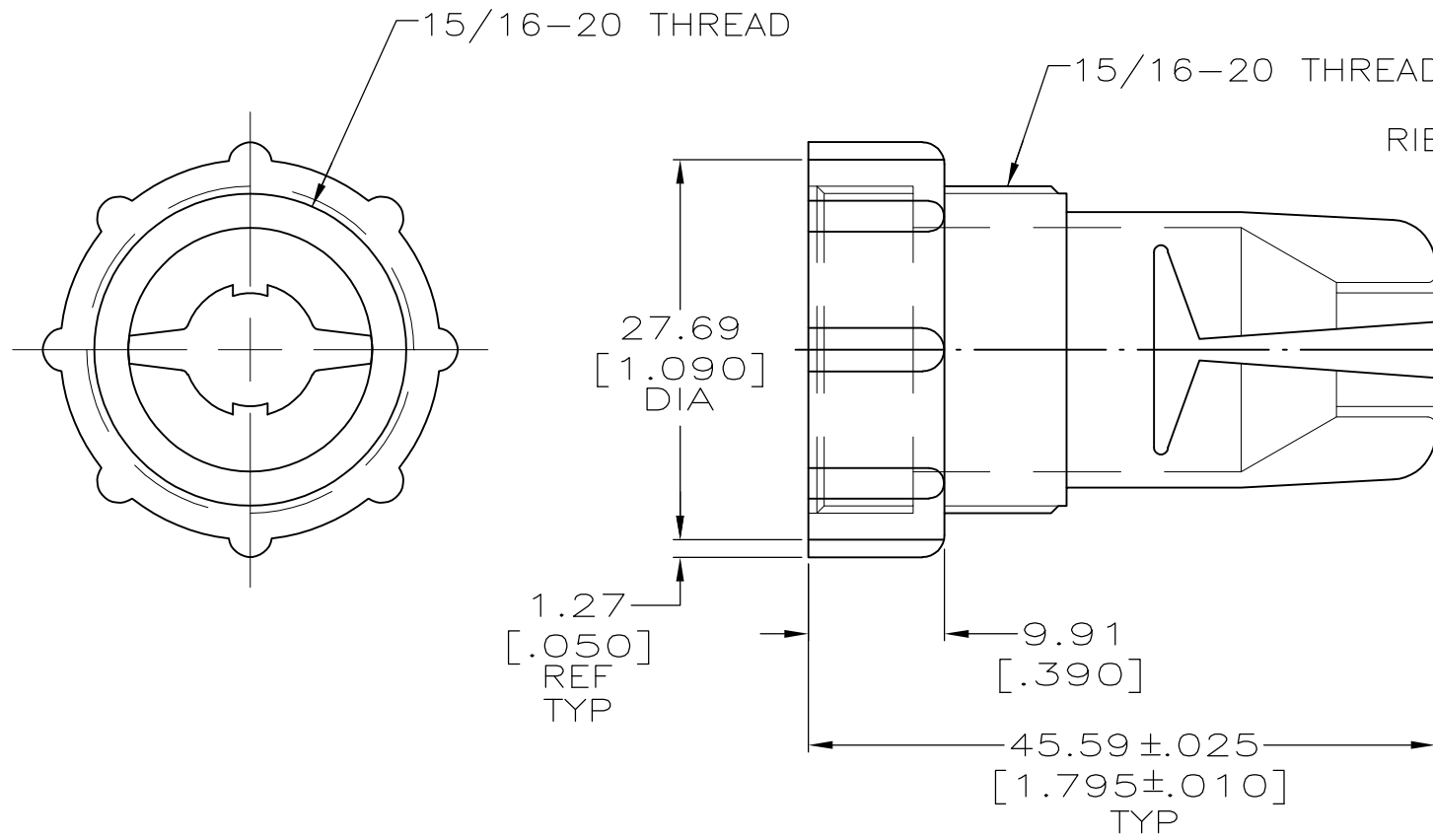

RIBS 207387-4 ONLY

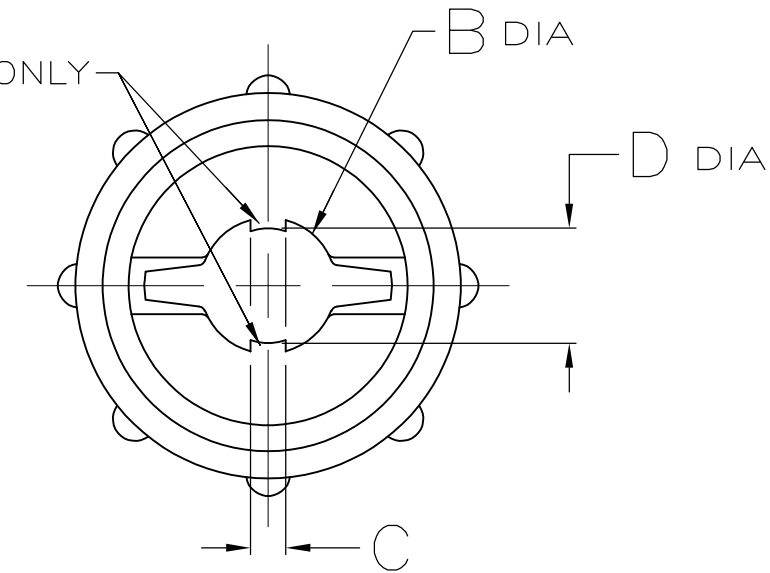

- ① CABLE RANGE OF 207387-1 WHEN USED WITH FLEXIBLE BOOT (P/N 207241-1) = 5.08-6.35[.200-.250] DIA.
- ② CABLE RANGE OF 207387-2, & 207387-4 WHEN USED WITH FLEXIBLE BOOT (P/N 207241-1) = 6.35-8.89[.250-.350] DIA.
- ③ OBSOLETE PART NUMBER.

8.26 [.325]	2.54 [.100]	9.78 [.385]	② 207387-4 ③
-	-	9.78 [.385]	② 207387-2
-	-	8.26 [.325]	① 207387-1
D	C	B	PART NUMBER

THIS DRAWING IS A CONTROLLED DOCUMENT.		DWN K.FOLTZ 06/20/94	STE TE Connectivity	
DIMENSIONS: MM[INCHES]		CHK R.STONE 06/24/94		
TOLERANCES UNLESS OTHERWISE SPECIFIED:		APVD A.FRANTUM 08/09/94	NAME CABLE GRIP, INTERNAL, SIZE 17, CPC	
0 PLC ± - 1 PLC ± - 2 PLC ± 0.13 [.005] 3 PLC ± - 4 PLC ± - ANGLES ± -		PRODUCT SPEC -	RESTRICTED TO -	
MATERIAL THERMOPLASTIC COLOR: BLACK	FINISH -	APPLICATION SPEC -	SIZE A3	CAGE CODE 00779
THIS DRAWING IS A CONTROLLED DOCUMENT FOR AMP INCORPORATED. IT IS SUBJECT TO CHANGE AND THE CONTROLLING ENGINEERING ORGANIZATION SHOULD BE CONTACTED FOR THE LATEST REVISION.		WEIGHT -	DRAWING NO C-207387	REV H1
CUSTOMER DRAWING			SCALE 2:1	SHEET 1 OF 1

Shield and Strain Relief Kit -- Straight Cable Clamp

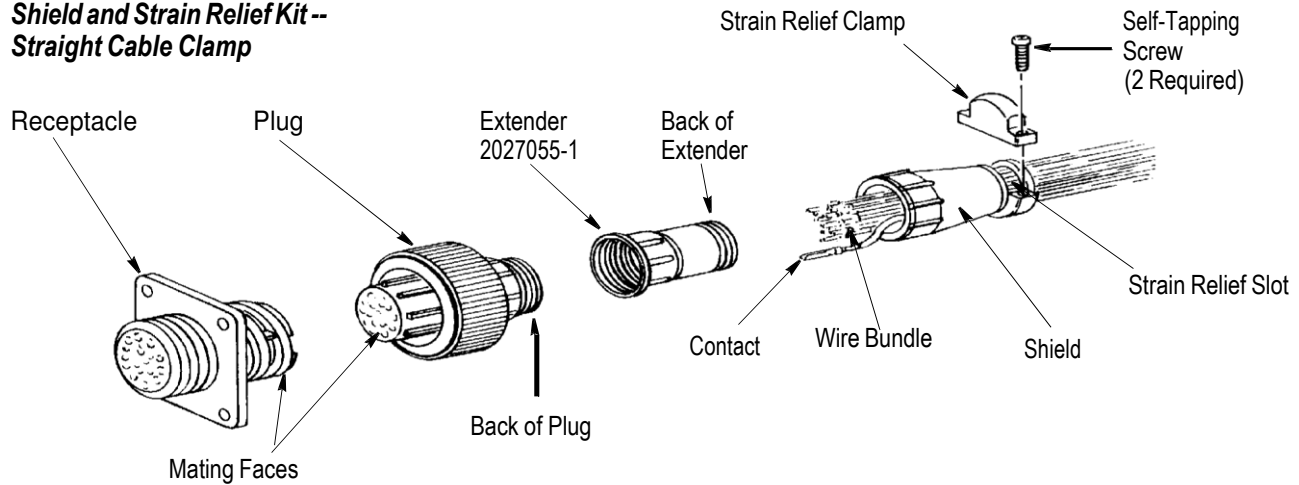

CONNECTOR SIZE	SHIELD AND STRAIN RELIEF KIT		CLAMP	
	SIZE	PART NUMBER	TYPE	QTY
11	Standard	1-206062-6	Reversible	1
	Standard	1-206062-4	Reversible	1
	Large	206358-5	Reversible	2
13	Standard	206966-7	Reversible	2
	Large	207008-5	Reversible	2
17	Standard	206070-8	Reversible	2
	Large	206322-9	Reversible	2
23	Standard	206138-8	Reversible	2
	Large	206512-5	Nonreversible	4
	Large	207774-3	Reversible	2

Figure 1

1. INTRODUCTION

This instruction sheet covers the installation of CPC shield and strain relief kits, extenders, flexible strain relief boots and grippers, jacketed cable sealing kits, sealing boots, peripheral seals, heat shrink sealing boots, sealing caps, keying plugs, coupling rings, and plug flanges.

Accessories are selected according to the connector size. The connector size is determined by measuring the distance across the coupling threads - plug or receptacle - and converting the dimension to 16ths of an inch. For example, Size 11 would measure 11/16ths of an inch across the coupling threads.

Read these instructions, and the material packaged with the connectors and crimp tooling, before installing any of the accessories.

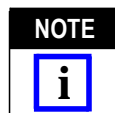

References to contacts, tooling, and instructional material are included in Instruction Sheet 408-7593, packaged with the connector.

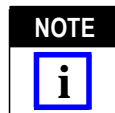

Dimensions are in metric units [with U.S. customary units in brackets], unless otherwise specified.

Reasons for reissue can be found in Section 14, REVISION SUMMARY.

2. DESCRIPTION

Shield and strain relief kits, available in straight or right-angle cable clamps, include a shield, strain relief clamps/saddle inserts, and two self-tapping screws. These kits can be attached to the plug and/or

receptacle of free-hanging or panel-mounted connectors.

Extenders are used with shield and strain relief (connector Size 23 only) to put the clamping area farther away from the rear of the connector.

Flexible strain relief boots and grippers are used with jacketed cable (or firmly taped discrete wires) to provide wire protection and to prevent contact pullout when severe cable-angle applications are encountered.

Jacketed cable sealing kits include a peripheral seal, boot-type cable seal, collar extender, and special strain relief clamp. These kits are used with the large-size shield and strain relief kits Size 23 only) on the plug and/or receptacle.

Sealing boots are used to provide splashproof protection at cable jacket and rear of plug and/or receptacle. They are NOT designed to be used with a shield and strain relief kit.

Peripheral seals provide splashproof protection, serve as a buffer at the connector mating face, and can be used for high vibration applications. The seal is recommended for use with applications of other sealing accessories.

Heat shrink sealing boots are used to provide a splashproof strain relief for jacketed cable. The sealing boot contains an inner plastic shell that threads onto the rear of a plug or receptacle and an outer tubing (with sealant) that shrinks around the cable jacket when heat is applied.

Sealing caps are installed on the receptacle mating face to protect the receptacle from moisture and dirt contamination when the plug is removed.

Keying plugs provide additional polarization for the connectors. The plugs are recommended for socket cavities only.

Plug flanges are used in applications that require the plug half of a connector to be panel-mounted.

The coupling ring, an integral part of the plug housing, is used to lock the connectors together. If the coupling ring should ever be damaged, it can be replaced. A special four-lobe coupling ring is available (for plugs only, Size 23) for use in applications where space is not critical, and when a more positive grip on the coupling is desired.

3. INSTALLING SHIELD AND STRAIN RELIEF KITS

3.1. Straight Cable Clamp Strain Relief Kits

Refer to the table in Figure 1 and select the appropriate shield and strain relief kit (standard or large) according to the connector size and the cable (wire bundle) diameter.

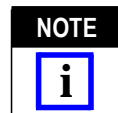

If the extender is to be used (connector Size 23 only), refer to Section 4, INSTALLING EXTENDER, and read that material before continuing with the following procedures.

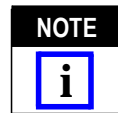

If sealing kit is to be used, refer to Section 6, INSTALLING JACKETED CABLE SEALING KITS, and install shield and strain relief kit according to those procedures.

For shield and strain relief installation (without sealing kit), proceed as follows:

1. Crimp contacts to wires according to instructional material packaged with crimp tooling.
2. Insert crimped contacts through BACK of shield. Then, insert contacts into housing according to instructions (408-7593) packaged with connector.
3. Slide shield forward and thread onto connector until it bottoms. DO NOT overtighten.

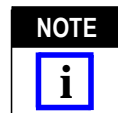

Mating the connectors before threading shield onto plug will prevent rotation of plug insert.

4. Select an appropriate size of strain relief clamp (eg, large clamp for small bundle) from the carrier strip that holds the clamps.

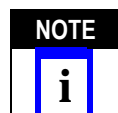

Clamping area is adjustable by inverting or changing the strain relief clamps. The quantity and type of clamps supplied with the kit are listed in Figure 1.

Insert strain relief clamp into strain relief slot until it bottoms. Clamp should bottom on wire bundle and NOT on shoulder of shield. Secure strain relief clamp with two self-tapping screws.

5. Make sure the wire bundle is properly secured. If strain relief clamp has bottomed on shoulder, or if clamp has NOT entered slot far enough, remove it and select another clamp (See Figure 3). After proper clamp has been installed, discard remaining strain relief clamp(s).

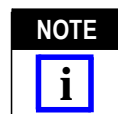

Strain Relief Kit 207774-3 for Size 23 comes with two clamps which can be configured as shown in Figure 4. The clamps are self-centering.

3.2. Right-Angle Cable Clamp Strain Relief Kits

Right-angle cable clamp strain relief kits are used in tight areas where typical straight cable clamp strain relief kits will not fit.

Refer to the table in Figure 2 and select the appropriate right-angle shield and strain relief kit according to the connector size and the cable (wire bundle) diameter.

NOTE When working with right-angle cable clamps, the strain relief clamps are referred to as saddle inserts.

NOTE If the extender is to be used (connector Size 23 only), refer to Section 4, INSTALLING EXTENDER, and read that material before continuing with the following procedures.

**Shield and Strain Relief Kit--
Right-Angle Cable Clamp**

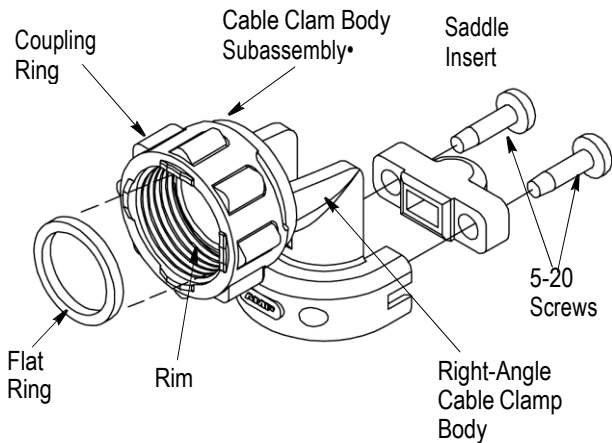

• The cable clamp body subassembly consists of the coupling ring and the right-angle cable clamp body.

CONNECTOR SIZE	PART NO.	FLAT RING USED	SADDLE INSERT QTY
11	796379-2	Yes	1
13	796380-2	No	2
17	796381-2	Yes	2
23	796382-2	Yes	2

Figure 2

For shield and strain relief installation (without sealing kit), proceed as follows:

1. Crimp contacts to wires according to instructional material packaged with crimp tooling.
2. Insert flat ring into clamp subassembly, making sure flat ring is not twisted and fully seated on rim.
3. Insert crimped contacts through BACK of shield. Then, insert contacts into housing according to instructions (408-7593) packaged with connector.
4. Slide cable clamp body subassembly forward and rotate body into position cables are to be run. Hold in position and thread coupling ring until tight. DO NOT overtighten.

NOTE Mating the connectors before threading shield onto plug will prevent rotation of plug insert.

5. Select an appropriate size saddle insert (eg, large insert for small bundle) from the carrier strip that holds the inserts.

NOTE Clamping area is adjustable by inverting or changing the saddle inserts. The quantity and of inserts supplied with the kit are listed in Figure 2.

Insert saddle insert into strain relief slot until it bottoms. Insert should bottom on wire bundle and NOT on shoulder of shield. Secure saddle insert with two self-tapping screws.

6. Make sure the wire bundle is properly secured. If saddle insert has bottomed on shoulder, or if insert has NOT entered slot far enough, remove it and select another insert (See Figure 3). After proper clamp has been installed, discard remaining strain relief clamp(s).

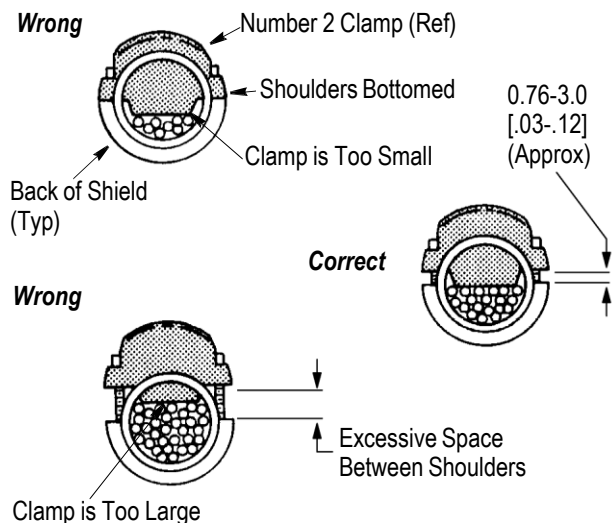

NOTE: These Views Represent Clamps with Fully Tightened Screws.

Figure 3

4. INSTALLING EXTENDER (Figure 1)

Extender 207055-1 is used in conjunction with the shield relief on connector Size 23 only.

After crimped contacts are passed through shield, they are inserted through the BACK of the extender (external threaded end) and then into the housing. The extender threads onto the BACK of the housing and the shield threads onto the BACK of the extender. This moves the strain relief area farther back on the cable so that pulling on the contacts is avoided. The use of more than one extender is not recommended.

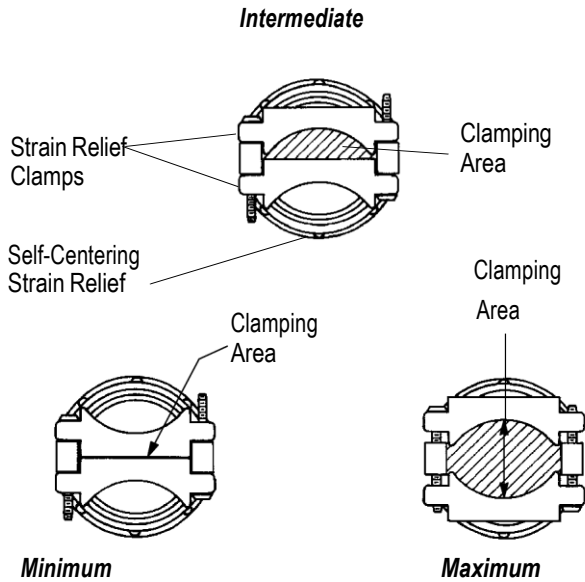
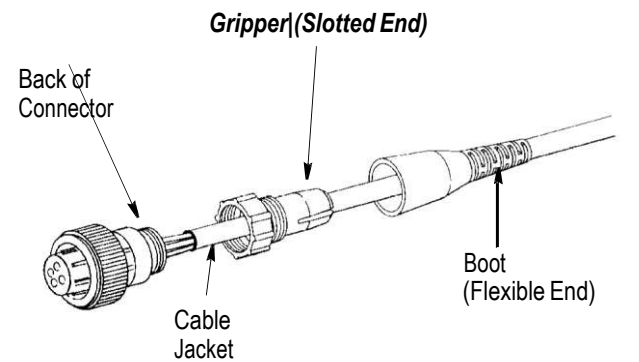

Figure 4

5. INSTALLING FLEXIBLE STRAIN RELIEF BOOTS AND GRIPPERS (Figure 5)

Refer to Figure 5 and select the appropriate boot and gripper according to the connector size and the cable jacket diameter.



CONNECTOR SIZE	CABLE JACKET OUTSIDE DIE	GRIPPER PART NO.	BOOT PART NO.
11	6.35 Max. [.250 Max.]	207490-1	207489-1
17	5.08-6.35 [.200-.250]	207387-1	207241-1
	6.35-8.89 [.250-.350]	207387-2	

Figure 5

Proceed as follows:

1. Install boot and gripper on cable before removing cable jacket. Slide boot onto cable - flexible end first. Slide gripper onto cable - slotted end first.
2. Crimp contacts to wires according to instructional material packaged with crimp tooling.
3. Insert contacts into housing according to instructions (408-7593) packaged with connector.
4. Thread gripper onto connector. Thread boot onto gripper until wire is tight. Do NOT overtighten.



CAUTION Overtightening of gripper on flexible boot can fracture boot.

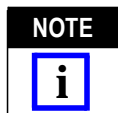

NOTE Some threads on gripper may be exposed on larger diameter wire.

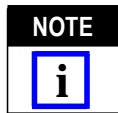

NOTE Mating the connectors before threading gripper and boot onto plug will prevent rotation of plug insert.

6. INSTALLING JACKETED CABLE SEALING KITS

The jacketed cable sealing kit is used with the large, Size 23 shield and strain relief kit only. Refer to Figure 6 and select the appropriate jacketed cable sealing kit according to the cable size and the cable jacket diameter.

Install sealing kit - with shield and strain relief kit - as follows:

1. Install following items before removing cable jacket. Thread shield onto extender and slide unit onto cable, shield portion first. Assemble collar on seal, just behind flange. Slide seal onto cable with flange toward cable end.
2. Crimp contacts to wires according to instructional material packaged with crimp tooling.
3. Insert contacts into housing according to instructions (408-7593) packaged with connector.
4. Position seal (flange portion) against BACK of housing. Slide extender/shield over seal and thread unit onto housing until it is finger tight. Then tighten unit an additional half-turn.

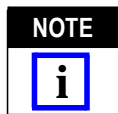

NOTE Mating the connectors before threading adapter/shield unit onto plug will prevent rotation of plug insert.

5. Insert strain relief clamp - the one included with the sealing kit - into strain relief slot until it bottoms on cable. Secure clamp with two self-tapping screws. Discard clamps included with strain relief kit.

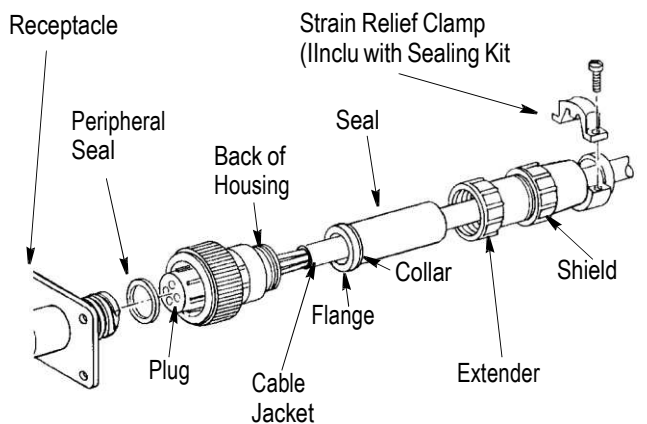

CONNECTOR SIZE	CABLE JACKET OUTSIDE DIA.	JACKED CABLE SEALING KIT
	7.62-11.43 [.300-.450]	207052-1
	11.43-15.24 [.450-.600]	207052-2
	15.24-22.23 [.600-.875]	207052-3

Figure 6

6. Insert peripheral seal into receptacle mating face until seal bottoms.

7. INSTALLING SEALING BOOTS

A sealing boot is used on jacketed cable only. Refer to Figure 7 and select the appropriate sealing boot according to the connector size.

NOTE Do NOT use sealing boot when using shield and strain relief kit.



Proceed as follows:

1. Slide sealing boot onto cable before removing cable jacket. Make sure boot collar is toward cable end.
2. Strip jacket (outer insulation) to approximately two-thirds the length of the sealing boot - a sufficient length of outer insulation must remain on the cable to ensure sealing when boot is installed.
3. Crimp contacts to wires according to instructional material packaged with crimp tooling.
4. Insert crimped contacts into housing according to 408-7593, packaged with connector.
5. Roll boot collar back over itself - turning collar inside out, and slide boot over cable until it butts against BACK of connector.
6. Roll collar forward and onto threaded portion of connector. Seat sealing ring edge on shoulder of connector.

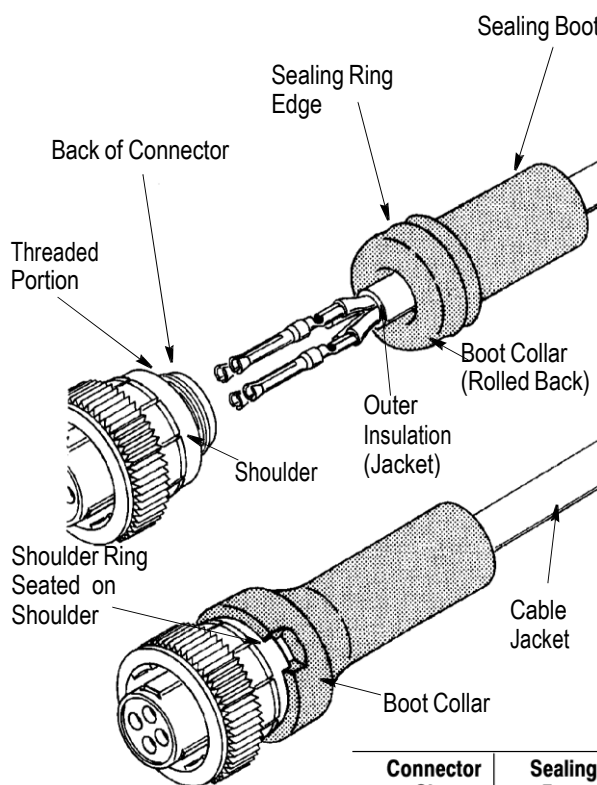

Connector Size	Sealing Boot
11	206304-1
17	--

Figure 7

7. A peripheral seal is recommended for splashproof protection at the connector mating face. Refer to Section 8, SELECTING AND INSTALLING PERIPHERAL SEAL.

8. SELECTING AND INSTALLING PERIPHERAL SEAL

The peripheral seal is recommended for sealing for boot and heat shrink sealing boot applications. The seal also serves as a buffer between mated connectors (sealed and unsealed applications).

Proceed as follows:

1. Refer to Figure 8 and select the appropriate peripheral seal according to the connector size.
2. Apply a bonding material, such as Loctite† Super Bonder 416, to seal to avoid loss of the seal during unmating; then insert seal into receptacle mating face until seal bottoms.

9. INSTALLING HEAT SHRINK SEALING BOOTS

Refer to Figure 9 the and select the appropriate heat shrink sealing boot according to the connector size.

† Loctite is a trademark.

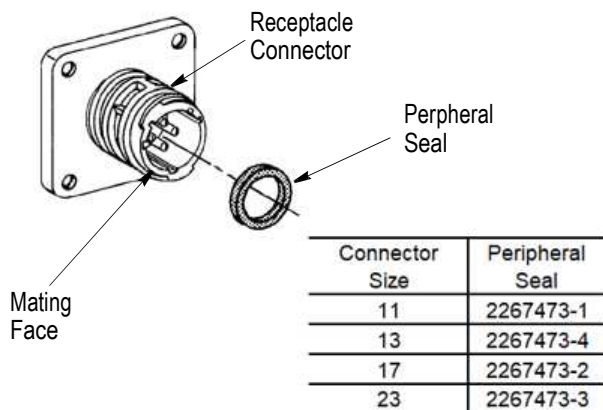
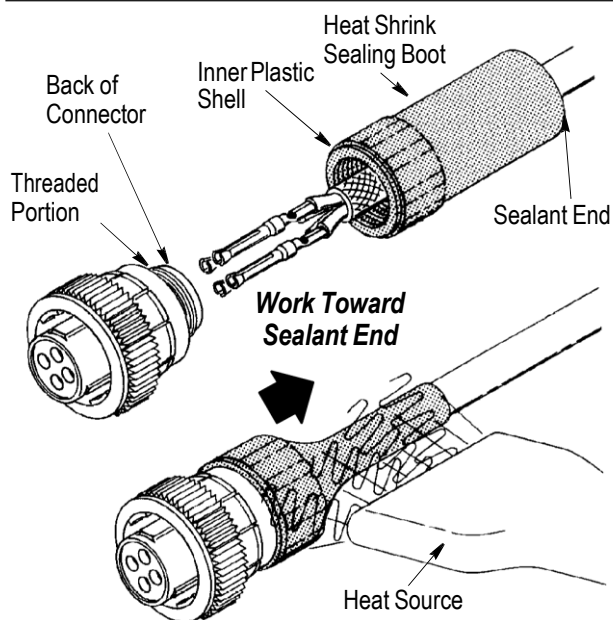

Figure 8

Proceed as follows:

1. Before removing cable jacket, slide heat shrink sealing boot onto cable, sealant end first.
2. Crimp contacts to wires according to instructional material packaged with crimp tooling.



CONNECTOR SIZE	HEAT SHRINK BOOT	CONNECTOR SIZE	HEAT SHRINK BOOT
11	54010-1	17	54011-1
13	54123-1	23	54012-1

Figure 9

3. Insert contacts into housing according to instructions (408-7593) packaged with connector.

NOTE Cable jacket should be roughened with sandpaper in area where sealing boot will be applied.

4. Thread sealing boot onto BACK of connector.

NOTE Mating the connectors before threading boot onto plug will prevent rotation of plug insert.

5. Use a heat source capable of delivering at least 121° C [250° F] - electrical heat gun, propane or butane torch, oven, or heat lamp.

6. Start close to BACK of connector and work toward sealant end of boot. Apply heat evenly around circumference of boot.

CAUTION Keep heat source in motion to avoid over-heating and possibly damaging cable jacket and plastic parts.

7. Shrink process is complete when sealant extrudes from end of boot.

8. A peripheral seal is recommended for splashproof protection at the connector mating face. Refer to Section 8, SELECTING AND INSTALLING PERIPHERAL SEAL.

10. INSTALLING SEALING CAPS

Refer to Figure 10 and select the appropriate sealing cap according to the connector size and series.

The sealing cap is threaded onto the receptacle mating face until the positive lock snaps into position. The free end of the strap can be secured to one of the mounting screws under the receptacle flange.

11. INSTALLING KEYING PLUGS

Keying plugs vary in configuration, and the installation procedures for each connector series are different. Identify the connector series to be keyed and proceed with A, B, or C as follows:

NOTE All keying plugs are inserted into connectors that are recommended for socket contacts (connectors with flush mating face).

11.1. Keying Series 1 Connectors (Figure 11)

Select Keying Plug 200821-1 and proceed as follows:

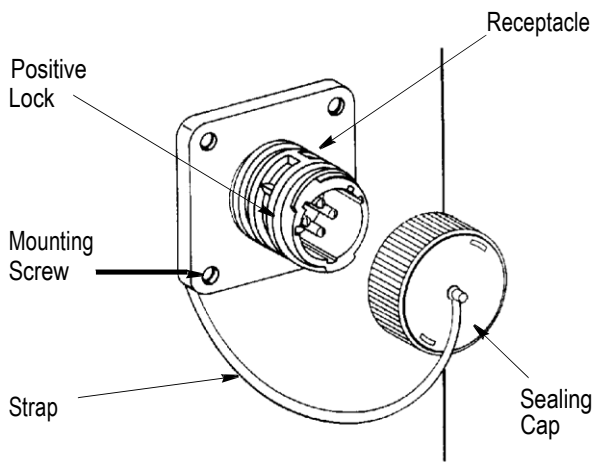

CONNECTOR		SEALING CAP	
SIZE	SERIES	PLASTIC STRAP	METAL CHAIN
11	1 & 2	206903-2	208800-1
13	1	211870-2	213485-1
17	1, 2, & 3	207445-3	208652-1
17	5&6	2423641-1	2423641-2
23	1 & 3	207446-3	208680-1
23	2	207446-4	208680-2

Figure 10

9. Align tapered end of plug with contact cavity. Insert plug straight into cavity until it snaps into position. When properly installed, plug should protrude from connector mating face approximately 0.79 [.031]

10. To remove keying plug, insert a suitable tool (3.18 [.125]-dia max drill rod) into BACK of keyed cavity and push plug out FRONT of connector.

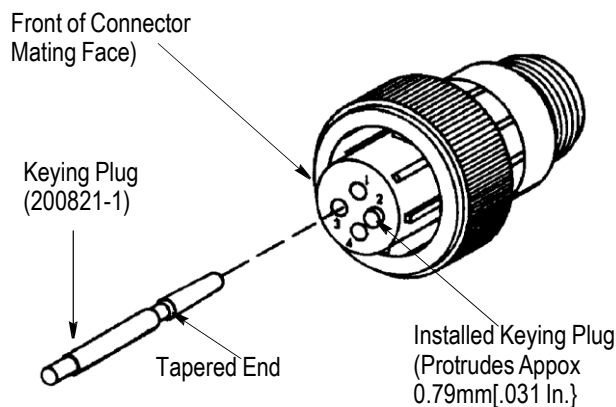

Figure 11

11.2. Keying Series 2 Connectors (Figure 12)

Select Keying Plug 206509-1 and proceed as follows:

1. Locate contact cavity to be keyed on FRONT (mating face) of connector.
2. Align pointed end of plug with contact cavity. Insert plug straight into cavity until head of plug bottoms on connector mating face.
3. To remove keying plug, insert a flat-bladed tool under head of plug and pry outward.

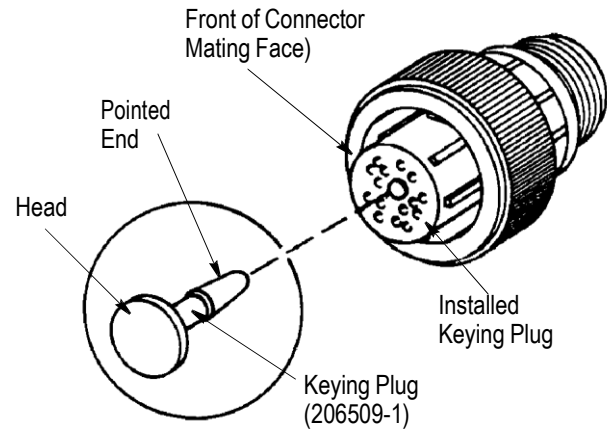



Figure 12

11.3. Keying Series 3 Connectors (Figure 13)

1. Locate contact cavity to be keyed on BACK (wire side) of connector.
2. Align cross-tip end of plug with contact cavity. Align locking lances with wider portion of cavity. Insert plug straight into cavity until it bottoms. Pull back lightly to be sure plug is locked in place.

NOTE  It is possible to install plug in wrong direction. This will NOT damage connector or keying plug. However, plug will NOT lock in position ... and will pull back out easily.

3. When properly installed, front of plug should be flush with connector mating face, and back of plug should protrude out BACK of connector approximately 3.2 [.125].

4. To remove keying plug, depress locking lances (through FRONT of connector) and push plug out BACK of cavity.

NOTE  Extraction Tool 91019-3 can be used to extract these keying plugs. Instructions 408-7276 for extraction tool use are packaged with the tool.

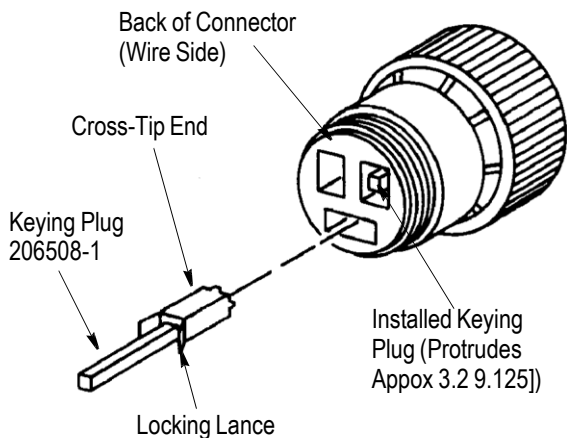

Figure 13

11.4. Keying Series 4 Connectors (Figures 13 and 11)

Follow procedures for Type XII Contacts (Paragraph 11.3) and Multimate Contacts (Paragraph 11.1.)

12. REPLACING COUPLING RING

The coupling ring is an integral part of the plug housing. In the event that it becomes damaged, or if the special coupling ring is to be installed (plug only Size 23), it can be replaced in the following manner.

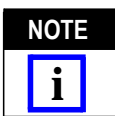

It is NOT necessary to extract contacts from the plug when replacing the coupling ring.

12.1. Removing Coupling Ring (Figure 14)

The coupling ring can be removed either by cutting the ring collar or by removing 3 or 4 splines and then sliding the ring off the FRONT of the connector. The latter method is accomplished by inserting a thin-bladed screwdriver between splines and prying outward.



Use care not to damage connector threads and keys.

12.2. Installing Coupling Ring (Figure 15)

A coupling ring is installed by applying even force to the outer perimeter of both the connector and the coupling ring. A small wheel puller with a recessed or open spindle is ideal for this application.

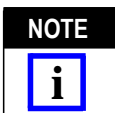

A properly installed coupling ring will recede approximately 3.2 [.125] beyond the mating face of the connector. Therefore, it is necessary for the spindle to be recessed or open.

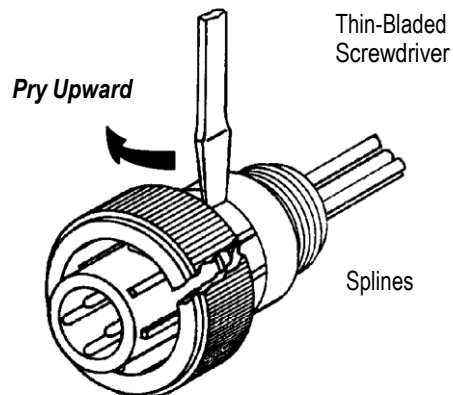

Removing Damaged Coupling Ring

Figure 14

Refer to Figure 15 and select the appropriate coupling ring according to the connector size.

Proceed as follows:

1. Orient coupling ring so splines are facing connector. Slide ring over FRONT of connector as far as it will go without using force.
2. Position tool grippers on BACK (wire side) of connector, being careful NOT to damage wires or threads. Position spindle on coupling ring.
3. Take up on spindle until components are snug, and check alignment of connector to spindle. Clearance must be available for connector mating face to enter spindle.
4. Tighten spindle until coupling ring splines spread and enter spline groove in connector. Remove tool and check that coupling ring is secure and that it rotates freely.

13. INSTALLING PLUG FLANGES (Figure 16)

Refer to Figure 16 and select the appropriate plug flange according to the connector size.

Proceed as follows:

1. Make cutout in panel according to the dimensions provided in Figure 16.
2. Install the flange and plug as shown in either View A or B, depending on your application. Secure flange with four commercially available screws and nuts.

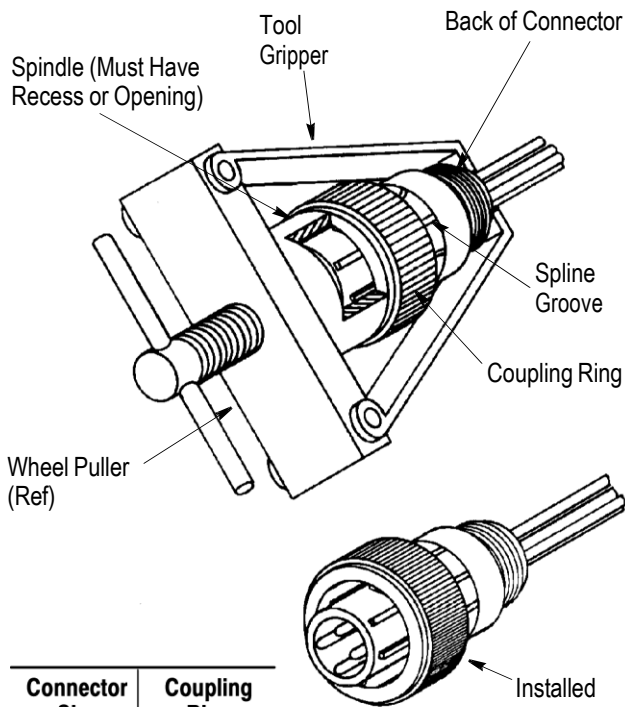

Connector Size	Coupling Ring
11	213811-1
13	213813-1
17	213810-1
23	213812-1
23	207659-1●

Installing Coupling Ring

● Special Four-Lobe Ring for Extra Grip

Figure 15

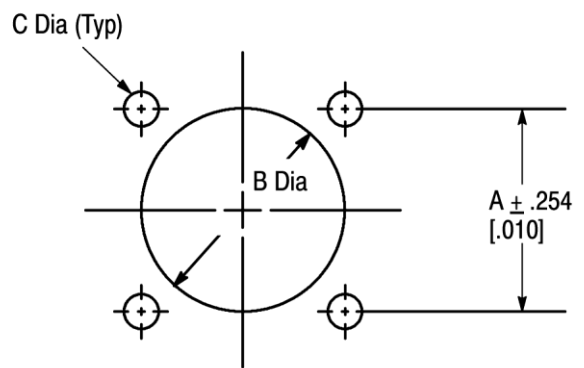
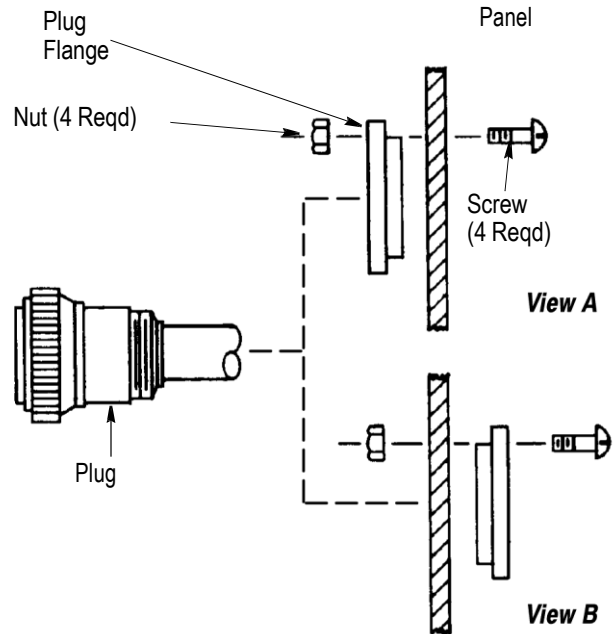

Panel Cutout 3.05 [.12] Panel Thickness

CONNECTOR SIZE	PLUG FLANGE	PANEL CUTOUT DIMENSION		
		A	B	C
11	207299-1	21.44 [.844]	21.34 [.840]	3.16 [.125]
13	207299-2	24.61 [.969]	24.87 [.979]	3.18 [.125]
17	207299-3	28.58 [1.125]	30.73 [1.210]	3.81 [.150]
23	207299-4	36.53 [1.438]	40.9 [1.610]	3.81 [.150]

Figure 16

14. PROTECTIVE CAPS

Protective caps are disposable and meant to protect the mating area of plugs and receptacles from dust and dirt during storage and handling. Use Figure 17 to select the appropriate protective cap based on the plug or receptacle shell size. Color choice does not impact function. Push the protective cap by hand onto the mating side of the plug or receptacle. Figure 18 shows protective caps being installed onto plugs and receptacles.

Cap Type	Shell Size	Color	Part Number	Description
Plug	11	Orange	2407269-1	CAP, CPC, SIZE 11 PLUG, ORANGE
		Black	2407269-2	CAP, CPC, SIZE 11 PLUG, BLACK
		Red	2407269-3	CAP, CPC, SIZE 11 PLUG, RED
		Yellow	2407269-4	CAP, CPC, SIZE 11 PLUG, YELLOW
Recp/Plug	11/13	Orange	1-2407269-1	CAP, CPC, SIZE 11 RECP & 13 PLUG, ORANGE
		Black	1-2407269-2	CAP, CPC, SIZE 11 RECP & 13 PLUG, BLACK
		Red	1-2407269-3	CAP, CPC, SIZE 11 RECP & 13 PLUG, RED
		Yellow	1-2407269-4	CAP, CPC, SIZE 11 RECP & 13 PLUG, YELLOW
Recp	13	Orange	2-2407269-1	CAP, CPC, SIZE 13 RECP, ORANGE
		Black	2-2407269-2	CAP, CPC, SIZE 13 RECP, BLACK
		Red	2-2407269-3	CAP, CPC, SIZE 13 RECP, RED
		Yellow	2-2407269-4	CAP, CPC, SIZE 13 RECP, YELLOW
Plug	17	Orange	3-2407269-1	CAP, CPC, SIZE 17 PLUG, ORANGE
		Black	3-2407269-2	CAP, CPC, SIZE 17 PLUG, BLACK
		Red	3-2407269-3	CAP, CPC, SIZE 17 PLUG, RED
		Yellow	3-2407269-4	CAP, CPC, SIZE 17 PLUG, YELLOW
Recp	17	Orange	4-2407269-1	CAP, CPC, SIZE 17 RECP, ORANGE
		Black	4-2407269-2	CAP, CPC, SIZE 17 RECP, BLACK
		Red	4-2407269-3	CAP, CPC, SIZE 17 RECP, RED
		Yellow	4-2407269-4	CAP, CPC, SIZE 17 RECP, YELLOW
Plug	23	Orange	5-2407269-1	CAP, CPC, SIZE 23 PLUG, ORANGE
		Black	5-2407269-2	CAP, CPC, SIZE 23 PLUG, BLACK
		Red	5-2407269-3	CAP, CPC, SIZE 23 PLUG, RED
		Yellow	5-2407269-4	CAP, CPC, SIZE 23 PLUG, YELLOW
Recp	23	Orange	6-2407269-1	CAP, CPC, SIZE 23 RECP, ORANGE
		Black	6-2407269-2	CAP, CPC, SIZE 23 RECP, BLACK
		Red	6-2407269-3	CAP, CPC, SIZE 23 RECP, RED
		Yellow	6-2407269-4	CAP, CPC, SIZE 23 RECP, YELLOW

Figure 17



Figure 18

15. REVISION SUMMARY

Added section 14 protective caps

Replaced superseded parts with active parts throughout the document.

Added series 5 & 6 sealing cap part numbers to Figure 10