

RA CONNECTOR

Disconnectable Crimp style connectors

勝特力材料 886-3-5753170
勝特力电子(上海) 86-21-34970699
勝特力电子(深圳) 86-755-83298787
Http://www.100y.com.tw



Crimp style receptacles that are designed to mate with headers conforming to MIL-C-83503. The low insertion force contacts reduce surface finish wear and resist stress relaxation very well.

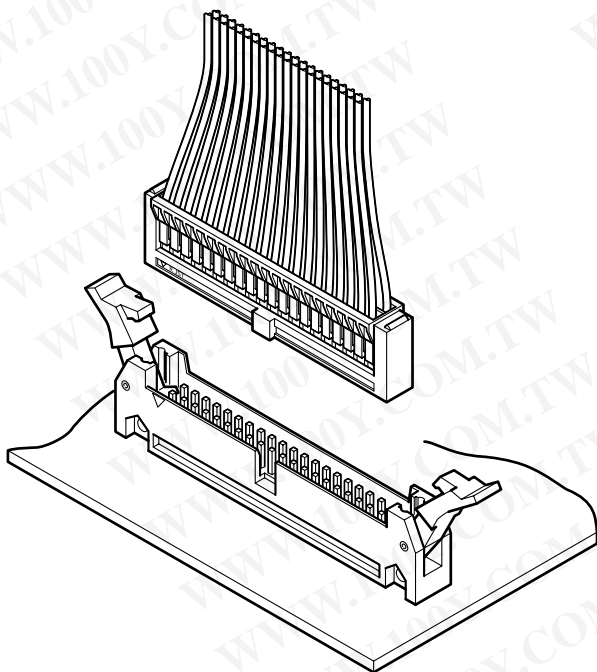

Features

• **Secure locking mechanism (RA, RX headers)**

The locking levers are engaged by inserting the receptacle into the header. This ensures a firm connection that's highly resistant to impact and vibration.

• **Housing lances**

The contact retention lances on the resilient housing allow visual confirmation of contact lock-in for easy and secure insertion.

• **Low insertion force contact**

The low insertion force contacts reduce surface finish wear and reduce the effects of stress relaxation.

• **Anti-misinsertion feature**

The guide devices of both housing and header prevent reverse connector insertion.

Specifications

- Current rating: 1.0A AC, DC (AWG #22)
- Voltage rating: 300V AC, DC
- Temperature range: -55°C to +85°C
(including temperature rise in applying electrical current)
- Contact resistance: Initial value/15m Ω max.
After environmental testing/30m Ω max.
- Insulation resistance: 1,000M Ω min.
- Withstanding voltage: 1,000V AC/minute
- Applicable wire: AWG #26 to #22
- Applicable PC board thickness: 1.6mm
- * Compliant with RoHS.
- * Refer to "General Instruction and Notice when using Terminals and Connectors" at the end of this catalog.
- * Contact JST for details.

Standards

Recognized E60389

RA CONNECTOR

Contact

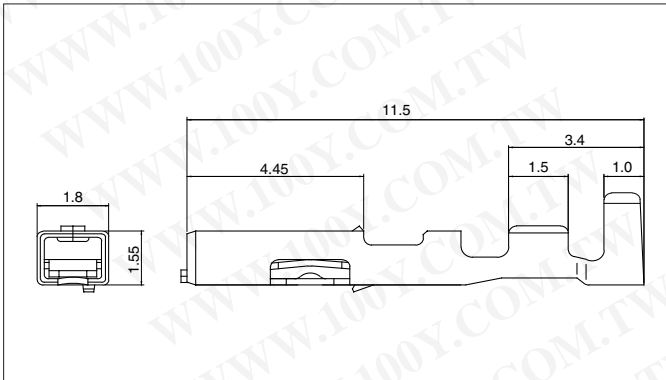

Model No.	Applicable wire			Q'ty / reel
	mm ²	AWG #	Insulation O.D. (mm)	
RA-SC1290	0.13 to 0.33	26 to 22	1.3 to 1.7	8,000

Material and Finish

Phosphor bronze, tin-plated (reflow treatment)

RoHS compliance

Note: Contact JST for gold-plated contacts.

Housing

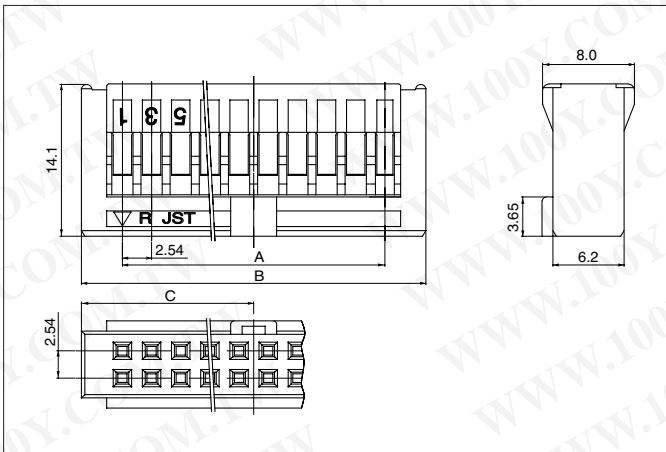

Circuits	Model No.	Dimensions (mm)			Q'ty / box
		A	B	C	
10	RA-1011	10.16	17.50	8.75	500
16	RA-1611	17.78	25.12	12.56	500
20	RA-2011	22.86	30.20	15.10	500
26	RA-2611	30.48	37.82	18.91	250
30	RA-3011	35.56	42.90	21.45	200
34	RA-3411	40.64	47.98	23.99	250
40	RA-4011	48.26	55.60	27.80	200
50	RA-5011	60.96	68.30	34.15	200
60	RA-6011	73.66	81.00	40.50	250

Material

Glass-filled PBT, UL94V-0, black

RoHS compliance

Header

The following headers are applicable to the above Housing.

Circuits	RA header		RX header		RK header	
	Top entry type	Side entry type	Top entry type	Side entry type	Top entry type	Side entry type
10	RA-H101TD-1190	RA-H101SD-1190	—	—	—	—
16	RA-H161TD-1190	RA-H161SD-1190	—	—	—	—
20	RA-H201TD-1190	RA-H201SD-1190	RX-H201TD-1190	RX-H201SD-1190	—	—
26	RA-H261TD-1190	RA-H261SD-1190	—	—	—	—
30	RA-H301TD-1190	—	—	—	—	—
34	RA-H341TD-1190	RA-H341SD-1190	RX-H341TD-1190	RX-H341SD-1190	RK-H341TD-0190	RK-H341SD-0190
40	RA-H401TD-1190	RA-H401SD-1190	RX-H401TD-1190	RX-H401SD-1190	RK-H401TD-0190	RK-H401SD-0190
50	RA-H501TD-1190	RA-H501SD-1190	RX-H501TD-1190	RX-H501SD-1190	—	—
60	RA-H601TD-1190	RA-H601SD-1190	RX-H601TD-1190	RX-H601SD-1190	—	—

RoHS compliance This product displays (LF)(SN) on a label.

Note: Contact JST for gold-plated headers.

Crimping machine, Applicator

Contact	Crimping machine	Crimp applicator	Dies	Crimp applicator with dies
RA-SC1290	AP-K2N	MKS-L	MK/RA-SC12	APLMK RA-SC12
		*MKS-SC	*SC/RA-SC12	APLSC RA-SC12

Note: *Strip-crimp applicator