

# 2.5mm Pitch Connector for Full Lock and Discrete Wire Connection

DF1E Series

UL, C-CL Listed

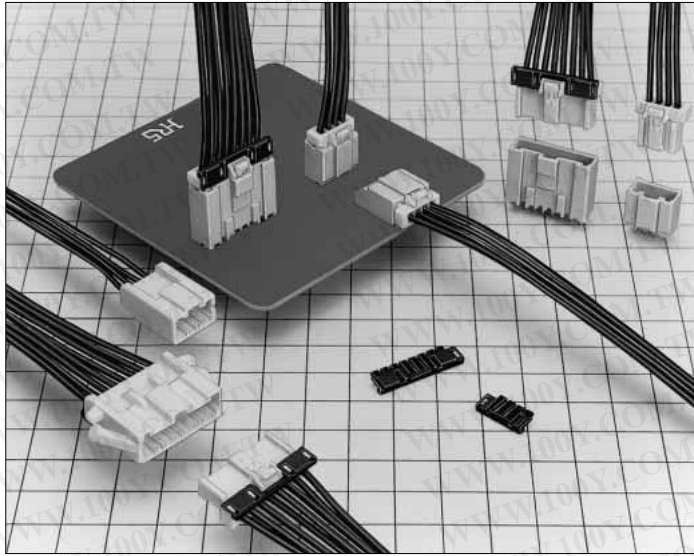

Full lock function added

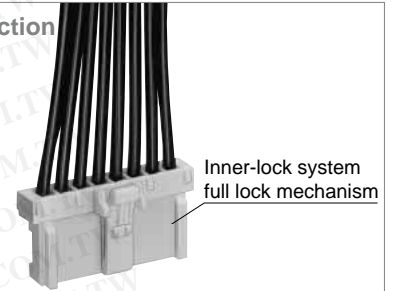

Mis-insertion prevention

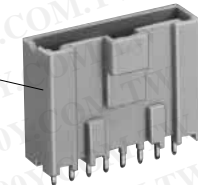

Photo 1

## ■ Features

### 1. Full Lock Function Added

The inner lock system adopts a full lock mechanism. This mechanism prevents disengagement to occur due to an unexpected external shock. (Refer to photo 1)

### 2. Increase in Crimping Contact Fixation Force and Semi-insertion Prevention

The double lock is activated for the use method to give a stress to the cable, to increase crimping contact fixation force, and to prevent the semi-insertion of the crimping contact. (Refer to photo 2)

### 3. Mold Lance Adopted

Since the contact lance may be deformed involving in the contact after the crimping process, the mold lance has been adopted.

### 4. Mis-insertion Prevention

Equipped with the mechanism to completely prevent reverse insertion and insertion between dissimilar contacts.

### 5. Means to Prevent Solder Crack

The glass enforcement resin is adopted for the pin header to prevent a solder crack to occur due to heat compression.

### 6. Correspond to Potting

Corresponding to potting, the pin header is provided for product variations.

Corresponding to potting up to 8mm and mounting height 19.8mm (no retainer), the low profile is achieved.

### 7. Production Facility Cost Reduction

The female crimping contact uses the DF1B series crimping contact, which has been conventionally marketed. Investment for new facilities isn't needed. However, if the retainer is installed in the cable with AWG#22 or more wire, use the DF1E crimping contact. The female crimping contact for in-line is used together with the DF1B applicator. Therefore, no investment is needed for new facilities.

Double lock engaged



Photo 2

### 8. Various Applications

With the same series, various applications can be used for the board solder dip type and in-line.

### 9. Listed by UL, C-UL

## ■ Applications

Electronic equipment, office machines, industrial equipment, and consumer equipment, and so on

勝特力材料 886-3-5753170  
勝特力电子(上海) 86-21-34970699  
勝特力电子(深圳) 86-755-83298787  
[Http://www.100y.com.tw](http://www.100y.com.tw)

## Products Specifications

Rating	Current rating Note 1. AWG#20 to 24 : 3A 26 : 2A 28 : 1A 30 : 0.5A Voltage rating 250VAC	Operating Temperature Range: -35 to +85°C Note 2. Operating Moisture Range : 40 to 80%	Storage Temperature Range : -10 to +60°C Note 3. Storage Moisture Range : 40 to 70% Note 3.
--------	---	---	--

C-UL Rating		
Rating	Current rating	AWG#20 to #22 : 3A AWG#24 to #28 : 1A AWG#30 : 0.5A
	Voltage rating	30V AC

■UL/C-UL File No. and Recognition No.  
 UL :E52653  
 C-UL :E52653

Item	Specification	Condition
1. Contact Resistance	30m ohms max.	Measured at 20mV max. and 1mA
2. Insulation Resistance	1000M ohms min.	500V DC
3. Withstanding voltage	No flashover or insulation breakdown.	650V AC/1 minute
4. Single Insertor/Extraction Forth	MIN 0.29N, MAX 4.41N	Measured at the square steel pin with 0.635±0.002
5. Durability (Mating/un-mating)	30m ohms max	30 cycles
6. Vibration	No electrical discontinuity of 1μs or more	Frequency: 10 to 55 Hz, single amplitude of 0.75 mm, 2 hours in each of the 3 directions.
7. Shock	No electrical discontinuity of 1μs or more	Acceleration of 490 m/s <sup>2</sup> , 11 ms duration, sine half-wave waveform, 3 cycles in each of the 3 axis
8. Humidity (Steady state)	30m ohms max	96 hours at temperature of 40±2°C and humidity of 90% to 95%
9. Temperature Cycle	30m ohms max.	(-55°C: 30 minutes-> 5 to 35°C: 5 minutes-> 85°C: 30 minutes-> 5 to 35°C: 5 minutes) 5 cycles
10. Resistance to Soldering heat	No deformation of components affecting performance.	Flow: 260°C for 10 seconds
		Manual soldering: 300°C for 3 seconds

Note 1: Current rating of header is 3A.

Note 2: Includes temperature rise caused by current flow.

Note 3: The term "storage" refers to products stored for long period of time prior to mounting and use. Operating Temperature Range and Humidity range covers non conducting condition of installed connectors in storage, shipment or during transportation.

Note 4: Information contained in this catalog represents general requirements for this Series. Contact us for the drawings and specifications for a specific part number shown.

## Material

Product	Part	Material	Treatment	Remarks
Socket	Insulator	Polyamide	White	UL94V-0
	Insulator	Polyamide	Beige	UL94V-0
Header	Contact	Brass	Tin-lead plated	_____
	Insulator	Polyamide	White	UL94V-0
In-line Plug	Insulator	Polyamide	Black	UL94V-0
retainer	Insulator	Polyamide	Black	UL94V-0
Crimping contact	Contact	Phosphor copper	Tin plated	_____

## Ordering Information

### Pin Header

**DF1E** **C** - **\*** **P** - **2.5** **DSA**  
 ① ② ③ ④ ⑤ ⑥

① Series Name : DF1E	③ Number of Contacts : 2 to 15 contacts (note. 2)												
② Hold Types (Note. 1)	④ Connector Type P : Pin Header												
<table border="1"> <tr> <th colspan="2">Standard Product</th> <th colspan="2">Potting</th> </tr> <tr> <td></td> <td>With Boss</td> <td></td> <td>With Boss</td> </tr> <tr> <td>C</td> <td>Without Boss</td> <td>G</td> <td>Without Boss</td> </tr> </table>	Standard Product		Potting			With Boss		With Boss	C	Without Boss	G	Without Boss	⑤ Contact Pitch : 2.5mm
Standard Product		Potting											
	With Boss		With Boss										
C	Without Boss	G	Without Boss										
	⑥ Form type DSA : Straight through hole DS : Right Angle Type												

Note 1 : The right angle pin header has no symbol.

Note 2 : The potting header has 2 to 10 contacts.

### Socket

**DF1E** - **\*** **S** - **2.5** **C**  
 ① ② ③ ④ ⑤

① Series Name : DF1E	③ Connector type S : Socket
② Number of Contacts : 2 to 15 contacts	④ Contact Pitch : 2.5mm
	⑤ Form Type C : Crimping socket

### In-line Plug

**DF1E** **A** - **\*** **EP** - **2.5** **C**  
 ① ② ③ ④ ⑤ ⑥

① Series Name : DF1E	③ Number of Contacts : 2 to 10 contacts
② In-line Plug type Blank: With Panel mount Lock A : Without Panel mount Lock	④ EP : In-line plug
	⑤ Contact Pitch : 2.5mm
	⑥ Form Type C : Crimping socket

### Crimping Contact

**DF1E** - **\*\*** **SCF**  
 ① ② ③

① Series Name :	② Applicable Cable Size
Socket side : DF1B (Note 1) DF1E (Note 1)	2022 : AWG#20 to #22 2428 : WG#24 to #28 30 : AWG#30
Plug side : DF1E	③ Packaging Type SCF : Female contact : Reel SC : Female contact : Bag PCF : Male contact : Reel PC : Male contact : Bag

Note 1 : When the retainer is used, use DF1E-2022SC(F), DF1B-2428SC(F), and DF1B-30SC(F) contacts.

When no retainer is used, all DF1B-\*\*SC(F) and DF1E-2022SC(F) contacts can be used.

### Retainer

**DF1E** - **\*** **RS/P** - **2.5**  
 ① ② ③ ④

① Series Name : DF1E	③ Connector Type RS/P : Retainer Commonly used for socket and in-line plug
② Number of Contacts : 2 to 10 contacts	④ Contacts Pitch:2.5mm

## Application Pattern

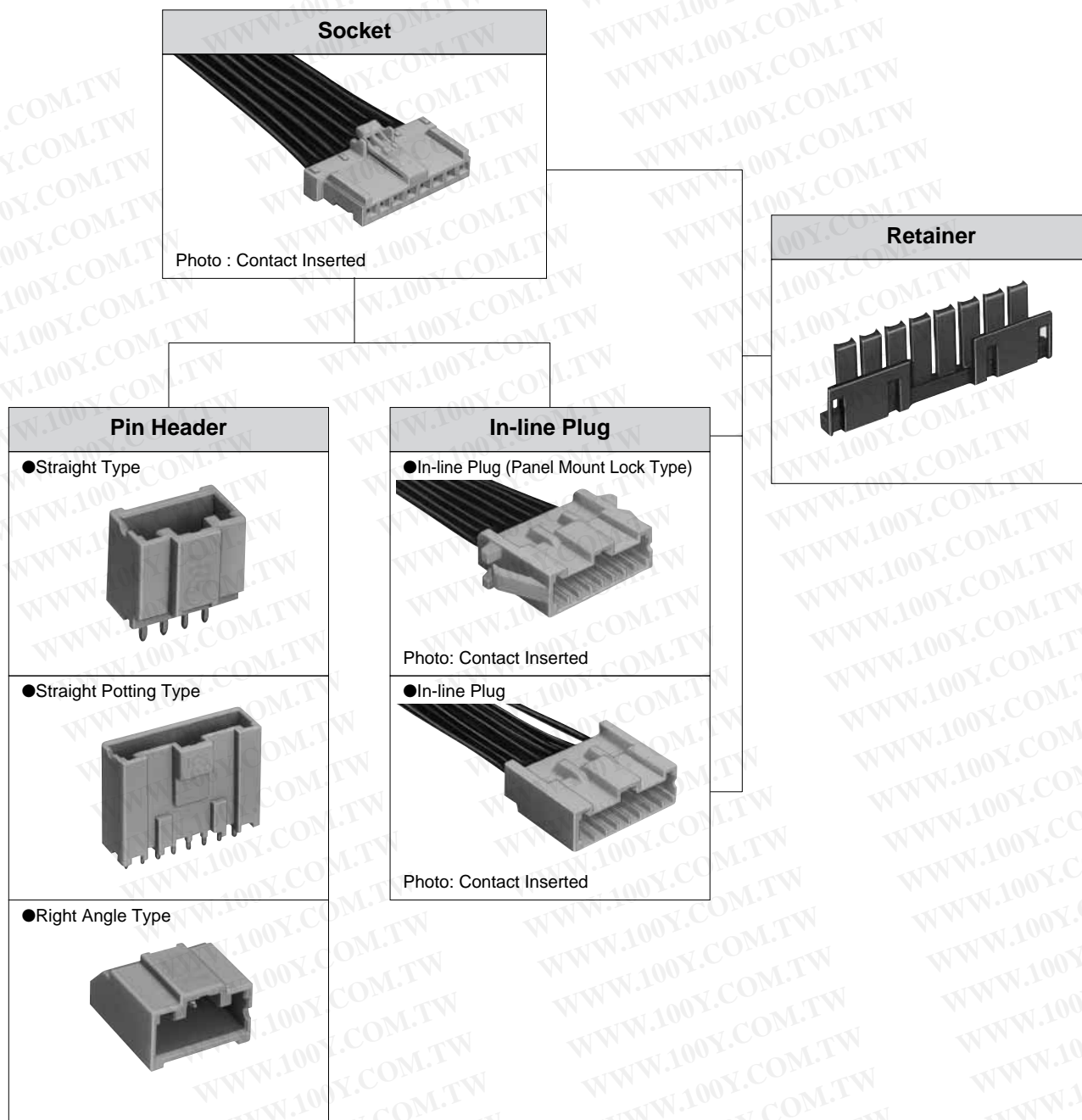

## Right Angle Pin Header

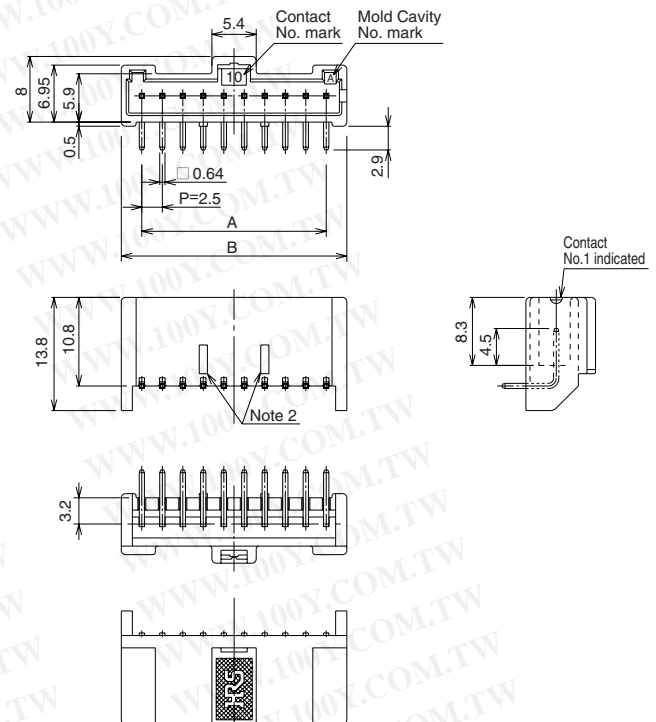

Part Number	CL No.	Number of Contacts	A	B	RoHS
DF1E - 2P-2.5DS(**)	541 - 0985- 0 -**	2	2.5	7.5	Yes
DF1E - 3P-2.5DS(**)	541 - 0986- 3 -**	3	5.0	10.0	
DF1E - 4P-2.5DS(**)	541 - 0987- 6 -**	4	7.5	12.5	
DF1E - 5P-2.5DS(**)	541 - 0988- 9 -**	5	10.0	15.0	
DF1E - 6P-2.5DS(**)	541 - 0989- 1 -**	6	12.5	17.5	
DF1E - 7P-2.5DS(**)	541 - 0990- 0 -**	7	15.0	20.0	
DF1E - 8P-2.5DS(**)	541 - 0991- 3 -**	8	17.5	22.5	
DF1E - 9P-2.5DS(**)	541 - 0992- 6 -**	9	20.0	25.0	
DF1E -10P-2.5DS(**)	541 - 0993- 9 -**	10	22.5	27.5	
DF1E -11P-2.5DS(**)	541 - 0994- 1 -**	11	25.0	30.0	
DF1E -12P-2.5DS(**)	541 - 0995- 4 -**	12	27.5	32.5	
DF1E -13P-2.5DS(**)	541 - 0996- 7 -**	13	30.0	35.0	
DF1E -14P-2.5DS(**)	541 - 0997- 0 -**	14	32.5	37.5	
DF1E -15P-2.5DS(**)	541 - 0998- 2 -**	15	35.0	40.0	

[Specific No.] -\*\* \*, (\*\* \*)  
 (01): Gold plated  
 (05): Tin plated

Note 1. : A packaging quantity is delivered by the bag unit (100 pcs.). If needed, please order the products per bag. However, the quantity for delivery will be changed according to the Specific No.

Note 2. : The 2 to 4 contacts differ in two convex portions from those in above figures. The 2 and 3 contacts are not contained, but the 4 contact connector is contained in the center at one point.

Note 3. : Styles of 2 to 4 contact connectors partially differ from those in above figures.

## PCB mounting pattern (Board Thickness $t = 1.6 \pm 0.1$ )

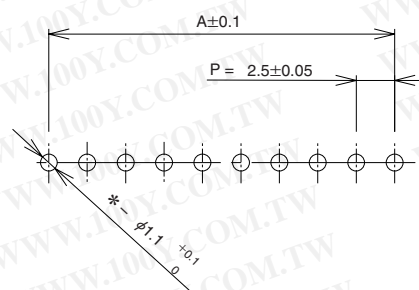

## ■Straight Pin Header

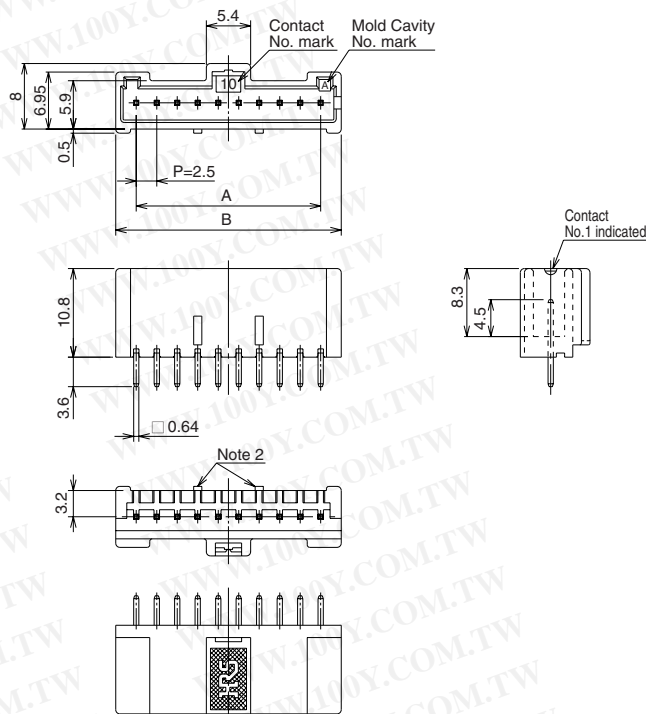

Part Number	CL No.	Number of Contacts	A	B	RoHS
DF1EC- 2P-2.5DSA(**)	541- 0867- 4 -**	2	2.5	7.5	Yes
DF1EC- 3P-2.5DSA(**)	541- 0868- 7 -**	3	5.0	10.0	
DF1EC- 4P-2.5DSA(**)	541- 0869- 0 -**	4	7.5	12.5	
DF1EC- 5P-2.5DSA(**)	541- 0870- 9 -**	5	10.0	15.0	
DF1EC- 6P-2.5DSA(**)	541- 0871- 1 -**	6	12.5	17.5	
DF1EC- 7P-2.5DSA(**)	541- 0872- 4 -**	7	15.0	20.0	
DF1EC- 8P-2.5DSA(**)	541- 0873- 7 -**	8	17.5	22.5	
DF1EC- 9P-2.5DSA(**)	541- 0874- 0 -**	9	20.0	25.0	
DF1EC-10P-2.5DSA(**)	541- 0875- 2 -**	10	22.5	27.5	
DF1EC-11P-2.5DSA(**)	541- 0876- 5 -**	11	25.0	30.0	
DF1EC-12P-2.5DSA(**)	541- 0877- 8 -**	12	27.5	32.5	
DF1EC-13P-2.5DSA(**)	541- 0878- 0 -**	13	30.0	35.0	
DF1EC-14P-2.5DSA(**)	541- 0879- 3 -**	14	32.5	37.5	
DF1EC-15P-2.5DSA(**)	541- 0880- 2 -**	15	35.0	40.0	

[Specific No.] -\*\* \*, (\*\* \*)  
 (01): Gold plated  
 (05): Tin plated

Note 1. : A packaging quantity is delivered by the bag unit (100 pcs.). If needed, please order the products per bag. However, the quantity for delivery will be changed according to the Specific No.

Note 2. : The 2 to 4 contacts differ in two convex portions from those in above figures. The 2 and 3 contacts are not contained, but the 2 and 3 contacts are not contained, and 4 contact is in the center at one point.

Note 3. : Styles of 2 to 4 contacts partially differ from those in above figures.

## ◆PCB mounting pattern (Board Thickness $t = 1.6 \pm 0.1$ )

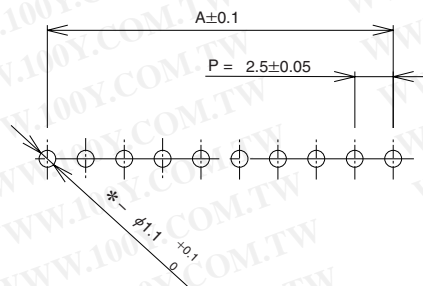

## ■ Straight Pin Header for Potting

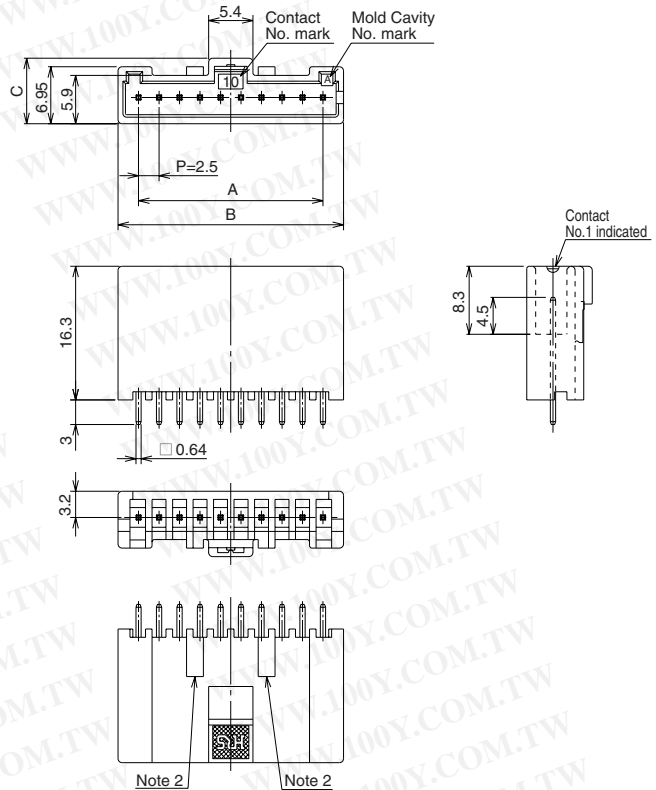
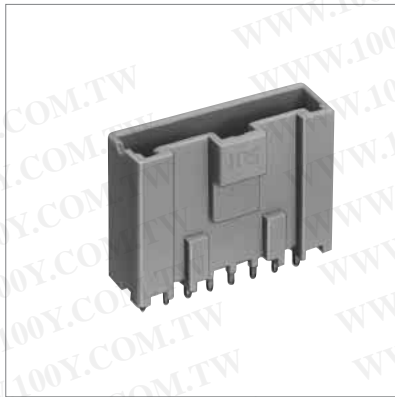

Part Number	CL No.	Number of Contacts	A	B	C	RoHS
DF1EG - 2P-2.5DSA(**)	541 - 0923 - 3**	2	2.5	7.5	8.0	Yes
DF1EG - 3P-2.5DSA(**)	541 - 0924 - 6**	3	5.0	10.0	8.0	
DF1EG - 4P-2.5DSA(**)	541 - 0925 - 9**	4	7.5	12.5	8.0	
DF1EG - 5P-2.5DSA(**)	541 - 0926 - 1**	5	10.0	15.0	7.8	
DF1EG - 6P-2.5DSA(**)	541 - 0927 - 4**	6	12.5	17.5	7.8	
DF1EG - 7P-2.5DSA(**)	541 - 0928 - 7**	7	15.0	20.0	7.8	
DF1EG - 8P-2.5DSA(**)	541 - 0929 - 0**	8	17.5	22.5	7.8	
DF1EG - 9P-2.5DSA(**)	541 - 0930 - 9**	9	20.0	25.0	7.8	
DF1EG - 10P-2.5DSA(**)	541 - 0931 - 1**	10	22.5	27.5	7.8	
DF1EG - 11P-2.5DSA(**)	541 - 0932 - 4**	11	25.0	30.0	7.8	

[Specific No.] - \* \*, (\* \*)  
 (05): Tin plated

Note 1. : A packaging quantity is delivered by the bag unit (100 pcs.). If needed, please order the product per bag. However, the quantity for delivery will be changed according to spec number.

Note 2. : The 2 to 6 and 9 to 10 contact connectors differ in two convex portions from those in above figures. The 2 to 5 and 9 to 10 contacts are not contained, but the 6 contact is bonded to the convex portion at both ends.

Note 3. : Styles of 2 to 4 contact may partially differ from the above figures.

## ◆ PCB mounting pattern (Board Thickness $t = 1.6 \pm 0.1$ )

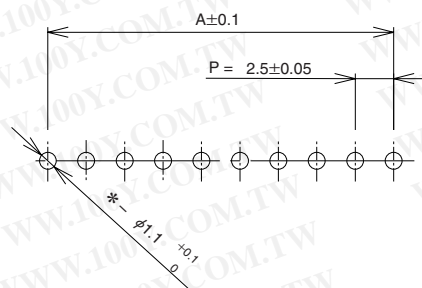

## ■ In-line Plug (Panel Mount Lock Type)

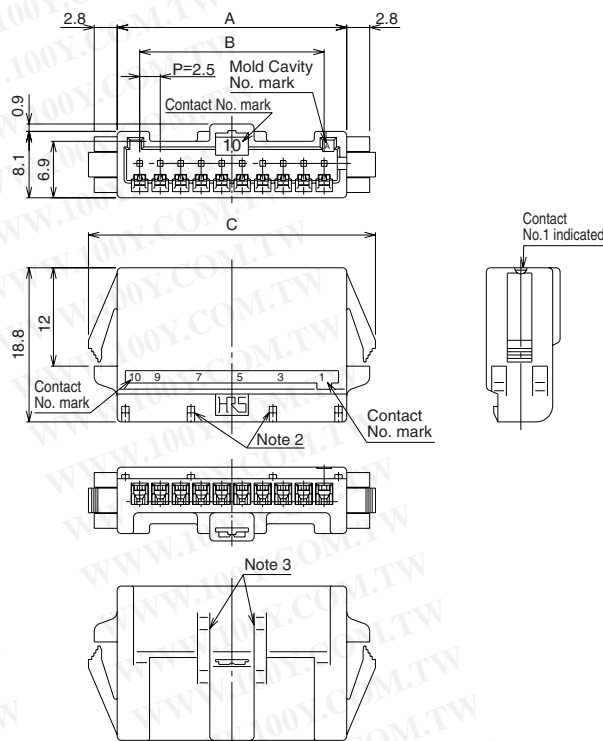

Part Number	CL No.	Number of Contacts	A	B	C	D	E	RoHS
DF1E- 2EP-2.5C	541- 0943- 0	2	8.0	2.5	15.0	8.4	11.9	Yes
DF1E- 3EP-2.5C	541- 0944- 3	3	10.5	5.0	17.5	10.9	14.4	
DF1E- 4EP-2.5C	541- 0945- 6	4	13.0	7.5	20.0	13.4	16.9	
DF1E- 5EP-2.5C	541- 0946- 9	5	15.5	10.0	22.5	15.9	19.4	
DF1E- 6EP-2.5C	541- 0947- 1	6	18.0	12.5	25.0	18.4	21.9	
DF1E- 7EP-2.5C	541- 0948- 4	7	20.5	15.0	27.5	20.9	24.4	
DF1E- 8EP-2.5C	541- 0949- 7	8	23.0	17.5	30.0	23.4	26.9	
DF1E- 9EP-2.5C	541- 0950- 6	9	25.5	20.0	32.5	25.9	29.4	
DF1E-10EP-2.5C	541- 0951- 9	10	28.0	22.5	35.0	28.4	31.9	

Note 1. : A packaging quantity is delivered by the bag unit (100 pcs.). If needed, please order the products per bag. However, the quantity for delivery will be changed according to the Specific No.

Note 2. : In regard to 2 to 5 contacts, the retainer fixed convex portions are located at both ends.

Note 3. In regard to 2 to 7 contacts, 2 convex portions are different from those in the above figures.

Note 4. Use the no radius side at the panel edge in the looking area.

Note 5. : Panel fixation is loosened. (May be enlarged according to the panel board thickness.)

Note 6. : Styles of 2 to 4 contact partially differ from those in the above figures.

\* Refer to page B156 for the retainer.

## ◆ Panel Cutout

Panel Thickness	X
1.7 to 2.0	1.5
1.3 to 1.6	1.0
0.9 to 1.2	0.5
0.7 to 0.8	0.0

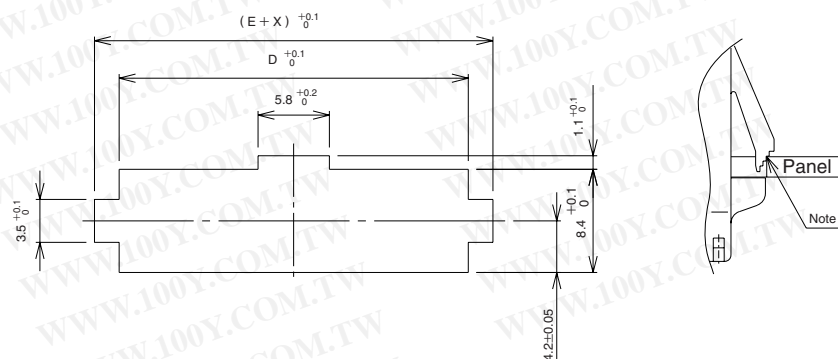

## In-line Plug

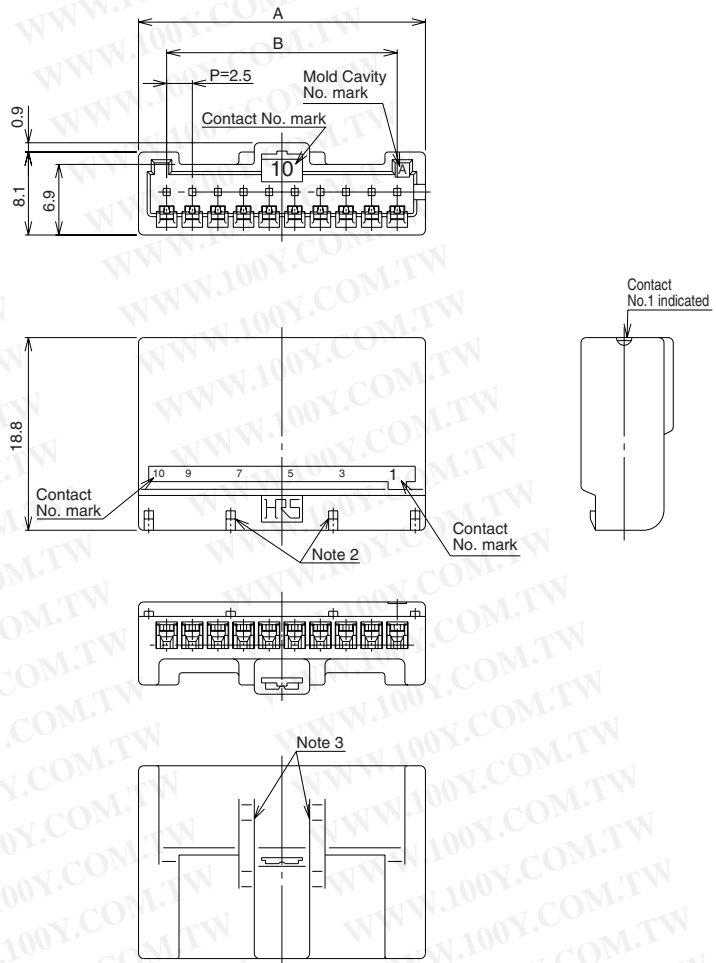

Part Number	CL No.	Number of Contacts	A	B	RoHS
DF1EA - 2EP-2.5C	541 - 0957 - 5	2	8.0	2.5	Yes
DF1EA - 3EP-2.5C	541 - 0958 - 8	3	10.5	5.0	
DF1EA - 4EP-2.5C	541 - 0959 - 0	4	13.0	7.5	
DF1EA - 5EP-2.5C	541 - 0960 - 0	5	15.5	10.0	
DF1EA - 6EP-2.5C	541 - 0961 - 2	6	18.0	12.5	
DF1EA - 7EP-2.5C	541 - 0962 - 5	7	20.5	15.0	
DF1EA - 8EP-2.5C	541 - 0963 - 8	8	23.0	17.5	
DF1EA - 9EP-2.5C	541 - 0964 - 0	9	25.5	20.0	
DF1EA - 10EP-2.5C	541 - 0965 - 3	10	28.0	22.5	

Note 1. : A packaging quantity is delivered by the bag unit (100 pcs.). If needed, please order the products per bag. However, the quantity for delivery will be changed according to the Specific No.

Note 2. : In regard to 2 to 5 contacts, the retainer fixed convex portions are located at both ends.

Note 3. : 2 to 7 contacts do not contain two convex portions, which is different from the above figure.

Note 4. : Styles of 2 to 4 contacts partially differ from the above figures.

\* Refer to page B156 for retainer.

## Socket

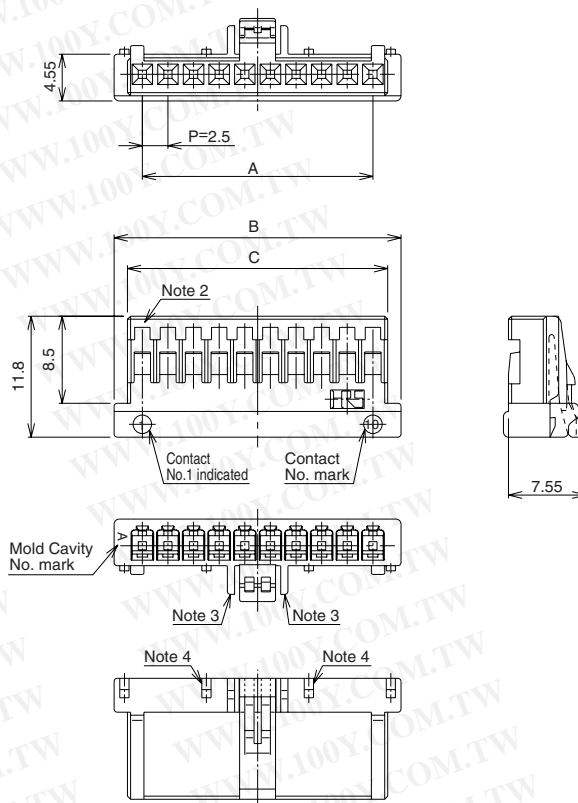

Part Number	CL No.	Number of Contacts	A	B	C	RoHS
DF1E – 2S–2.5C	541 – 0811 – 0	2	2.5	8.0	5.4	Yes
DF1E – 3S–2.5C	541 – 0812 – 2	3	5.0	10.5	7.9	
DF1E – 4S–2.5C	541 – 0813 – 5	4	7.5	13.0	10.4	
DF1E – 5S–2.5C	541 – 0814 – 8	5	10.0	15.5	12.9	
DF1E – 6S–2.5C	541 – 0815 – 0	6	12.5	18.0	15.4	
DF1E – 7S–2.5C	541 – 0816 – 3	7	15.0	20.5	17.9	
DF1E – 8S–2.5C	541 – 0817 – 6	8	17.5	23.0	20.4	
DF1E – 9S–2.5C	541 – 0818 – 9	9	20.0	25.5	22.9	
DF1E – 10S–2.5C	541 – 0819 – 1	10	22.5	28.0	25.4	
DF1E – 11S–2.5C	541 – 0820 – 0	11	25.0	30.5	27.9	
DF1E – 12S–2.5C	541 – 0821 – 3	12	27.5	33.0	30.4	
DF1E – 13S–2.5C	541 – 0822 – 6	13	30.0	35.5	32.9	
DF1E – 14S–2.5C	541 – 0823 – 9	14	32.5	38.0	35.4	
DF1E – 15S–2.5C	541 – 0824 – 1	15	35.0	40.5	37.9	

Note 1. : A packaging quantity is delivered by the bag unit (100 pcs.). If needed, please order the products per bag. However, the quantity for delivery will be changed according to spec number.

Note 2. : The 2 contact connector is equipped with the convex portion to prevent false-insertion.

Note 3. : The 2 consult Has no wall on the locking side

Note 4. : The 2 to 5 contacts contain the retainer fixed convex portions at both ends.

\* Refer to page B156 for the retainer.

## Retainer

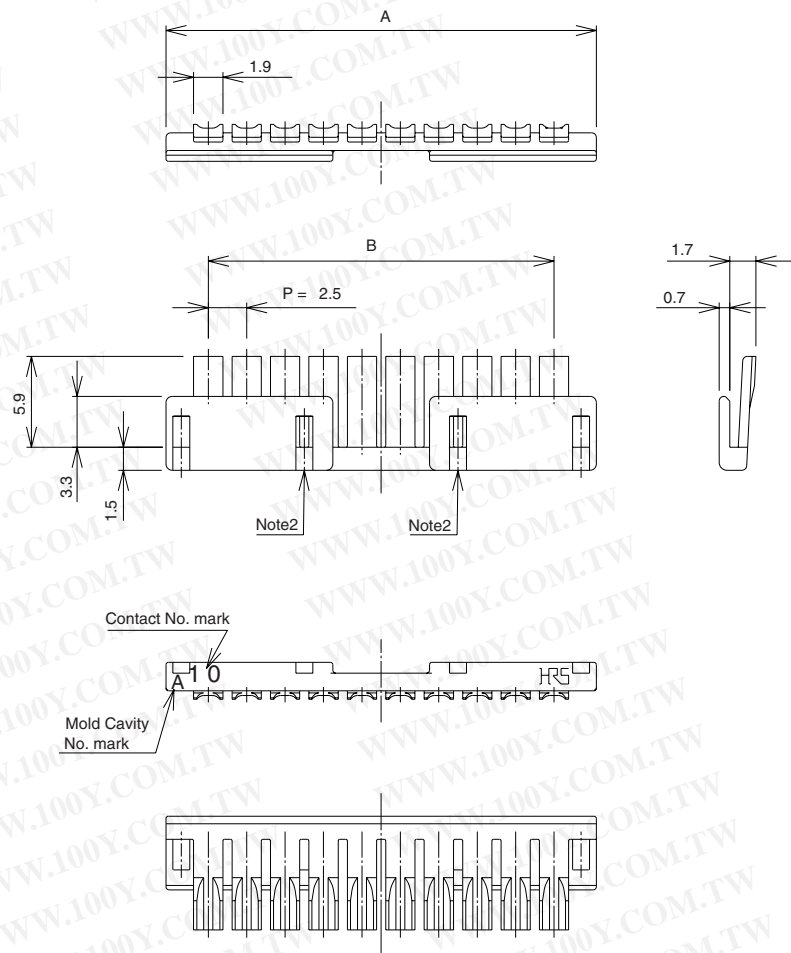
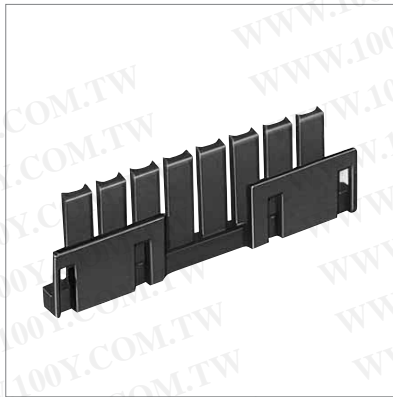

Part Number	CL No.	Number of Contacts	A	B	RoHS
DF1E - 2RS/P-2.5	541 - 0971 - 6	2	8.0	2.5	Yes
DF1E - 3RS/P-2.5	541 - 0972 - 9	3	10.5	5.0	
DF1E - 4RS/P-2.5	541 - 0973 - 1	4	13.0	7.5	
DF1E - 5RS/P-2.5	541 - 0974 - 4	5	15.5	10.0	
DF1E - 6RS/P-2.5	541 - 0975 - 7	6	18.0	12.5	
DF1E - 7RS/P-2.5	541 - 0976 - 0	7	20.5	15.0	
DF1E - 8RS/P-2.5	541 - 0977 - 2	8	23.0	17.5	
DF1E - 9RS/P-2.5	541 - 0978 - 5	9	25.5	20.0	
DF1E - 10RS/P-2.5	541 - 0979 - 8	10	28.0	22.5	

Note 1. : A packaging quantity is delivered by the bag unit (100 pcs.). If needed, please order the products per bag. However, the quantity for delivery will be changed according to spec number.

Note 2. : The 2 to 4 contacts contain socket and plug fixed holes at both ends.

\* This retainer can be used together with the socket and relay plug.

## ■ Plug Crimping Contact

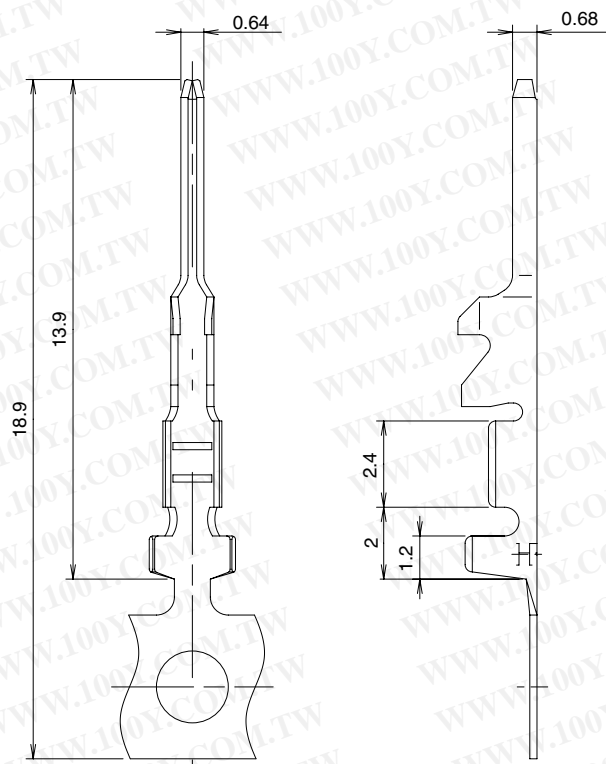

### ● Applicable Cable (Tin plating annealed copper wire)

Conductor Size (Wire construction)
AWG # 20 (21 cores./0.18mm)
AWG # 22 (17 cores./0.16mm)
AWG # 24 (11 cores./0.16mm)
AWG # 26 ( 7 cores./0.16mm)
AWG # 28 ( 7 cores./0.127mm)
AWG # 30 ( 7 cores./0.1mm)

### ● Recommended Cable

UL1061, UL1007

### ● Strip Length

3.0 to 3.7mm

Note : If other cables are used instead of the applicable cable, contact Hirose sales department.

Part Number	CL No.	Applicable Cable Indication	Applicable Cable		Packaging Type	Quantity	RoHS
			AWG	Jacket Diameter			
DF1E – 2022PCF	541 – 0937 – 8	20	AWG # 20	1.2 to 1.9mm	Reel	10,000	Yes
DF1E – 2022PC	541 – 0938 – 0	22	AWG # 22		Bag	100	
DF1E – 2428PCF	541 – 0939 – 3	24	AWG # 24	0.9 to 1.5mm	Reel	10,000	
DF1E – 2428PC	541 – 0940 – 2	28	AWG # 28		Bag	100	
DF1E – 30PCF	541 – 0941 – 5	30	AWG # 30	0.6 to 1.2mm	Reel	10,000	
DF1E – 30PC	541 – 0942 – 8				Bag	100	

● Crimping Contact Extraction Tool DF-C-PO(B)

## Socket Crimping Contact

### DF1E-2022SCF

### DF1B - \* \* \* \* SCF

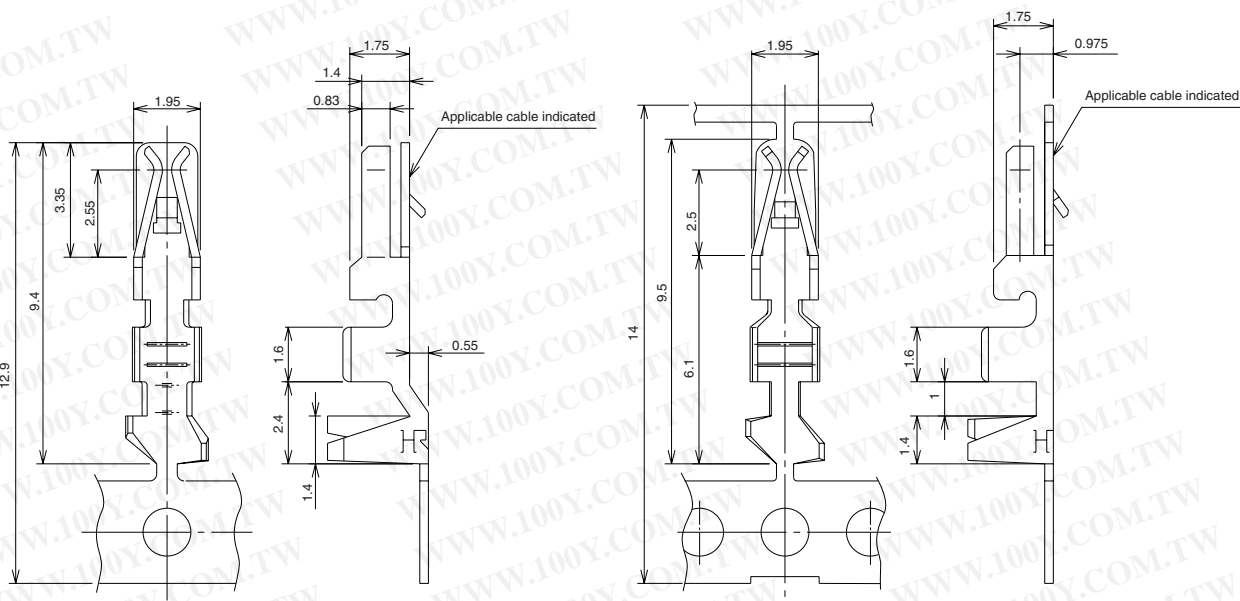

#### Applicable Cable (Tin plating annealed copper wire)

Conductor Size (Wire construction)
AWG # 20 (21 cores./0.18mm)
AWG # 22 (17 cores./0.16mm)
AWG # 24 (11 cores./0.16mm)
AWG # 26 ( 7 cores./0.16mm)
AWG # 28 ( 7 cores./0.127mm)
AWG # 30 ( 7 cores./0.1mm)

#### Recommended Cable

UL1061, UL1007

#### Strip Length

2.0mm to 2.5mm

Note : If other cables are used instead of the applicable cable, consult Hirose sales department.

Part Number	CL No.	Applicable Cable Indication	Applicable Cable		Packaging Type	Quantity	RoHS
			AWG	Jacket Diameter			
DF1E - 2022SCF	541 - 0999 - 5	20	AWG # 20	1.2 to 1.9mm	Reel	10,000	Yes
DF1E - 2022SC	541 - 1000 - 2	22	AWG # 22		Bag	100	
DF1B - 2022SCF	541 - 0223 - 1	20	AWG # 20	1.2 to 1.9mm	Reel	10,000	
DF1B - 2022SC	541 - 0224 - 4	22	AWG # 22		Bag	100	
DF1B - 2428SCF	541 - 0678 - 1	24	AWG # 24	0.9 to 1.5mm	Reel	10,000	
DF1B - 2428SC	541 - 0679 - 4	28	AWG # 28		Bag	100	
DF1B - 30SCF	541 - 0682 - 9	30	AWG # 30	0.6 to 1.2mm	Reel	10,000	
DF1B - 30SC	541 - 0683 - 1				Bag	100	

● Crimping Contact Extraction Tool DF-C-PO(B)

## ◆ Crimping Tools

Item	Part Number	CL No.	Applicable Contact
Applicator	AP105 – DF1E – 2022S	901 – 4561 – 0	DF1E – 2022SCF
	AP105 – DF1B – 2022S ◎	901 – 4510 – 9	DF1B – 2022SCF
	AP105 – DF1B – 2428S ◎	901 – 4518 – 0	DF1B – 2428SCF
	AP105 – DF1B – 30S ◎	901 – 4517 – 8	DF1B – 30SCF
	AP105 – DF1B – 2022P ◎	901 – 4509 – 0	DF1E – 2022PCF
	AP105 – DF1B – 2428P ◎	901 – 4521 – 5	DF1E – 2428PCF
	AP105 – DF1B – 30P ◎	901 – 4519 – 3	DF1E – 30PCF
Main Press Unit	CM – 105 ◎	901 – 0005 – 4	—
Manual Crimping Tool	HT102/DF1E – 2022S	550 – 0277 – 1	DF1E – 2022SC
	DF1B – TA2022SHC ◎	550 – 0182 – 7	DF1B – 2022SC
	DF1B – TA2428SHC ◎	550 – 0209 – 1	DF1B – 2428SC
	DF1B – TA30SHC ◎	550 – 0211 – 3	DF1B – 30SC
	HT102/DF1BE – 2022P	550 – 0278 – 4	DF1E – 2022PC
	HT102/DF1BE – 2428P	550 – 0279 – 7	DF1E – 2428PC
	HT102/DF1BE – 30P	550 – 0280 – 6	DF1E – 30PCF
Contact Extraction Tool	DF – C – PO (B)	550 – 0179 – 2	DF1E – 2022SC (F) DF1B – * * * * SC (F) DF1E – * * * * PC (F)

Note 1. : Add "◎" to the last number of the product, in order to use DF1B series tools, which have been conventionally merchandized.

Note 2. : If any trouble has occurred due to other tools, which are not designated by Hirose, Hirose won't guarantee any products.

## Application Pattern

### Standard Header

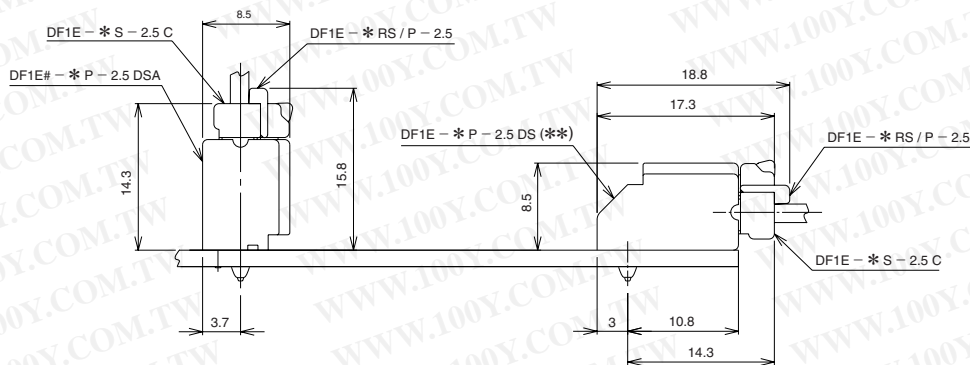

### Header for Potting

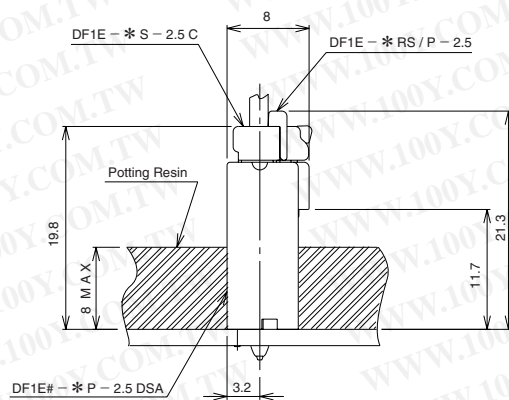

### Panel Mounting Lock In-line Plug

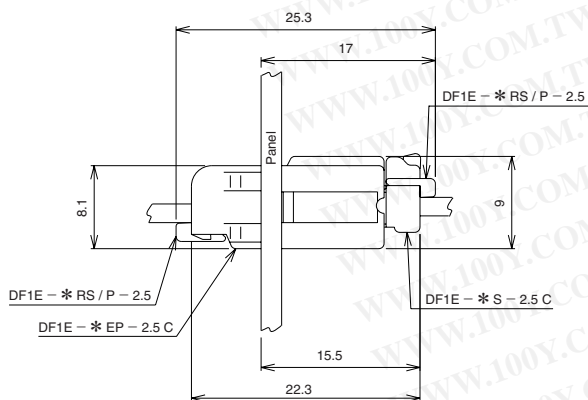

### In-line Plug

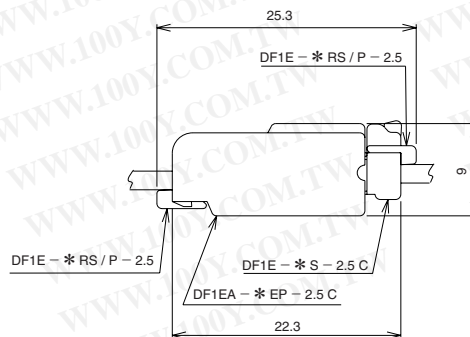

## ◆ Precautions

1. Recommended Soldering Condition	Flow: 260°C for 10 seconds Manual soldering: 300°C for 3 seconds
2. Cleaning Condition	Refer to Nylon Connector Use Hand book. However, if the connector is cleaned by the potting header, the detergent remains within the connector, which will cause malfunction.
3. Connection Condition	Refer to Nylon Connector Use Hand book.
4. Cautions	<ul style="list-style-type: none"> <li>● To remove the connector, if the connector is forcedly removed, it will cause connector damage. If the connector is hardly removed, slightly push the connector once, and then remove it using the lock.</li> <li>● In some method for laying the cable within equipment, a tension may be applied to the cable so as to remove the contact. In this case, it is recommended to use the retainer.</li> <li>● Incomplete insertion of the contact can be prevented by mounting a retainer; however, mounting of a retainer might not be possible when the contact protrudes beyond the socket. Insert the contact securely and then mount the retainer.</li> <li>● If the potting process is implemented, it is desirable to fill the connector with resin, considering the resin surface tensile force.</li> <li>● The color phase of this product may be slightly different from that of the forming product according to the manufacturing lot and future storage conditions, however the difference doesn't affect the performance.</li> </ul>
5. Precautions	Refer to Nylon Connector Use Hand book.

**勝特力材料 886-3-5753170**  
**勝特力电子(上海) 86-21-34970699**  
**勝特力电子(深圳) 86-755-83298787**  
**Http://www.100y.com.tw**