

Compact Flash® Card Connectors Complies with Compact Flash Association

MI20/21 Series

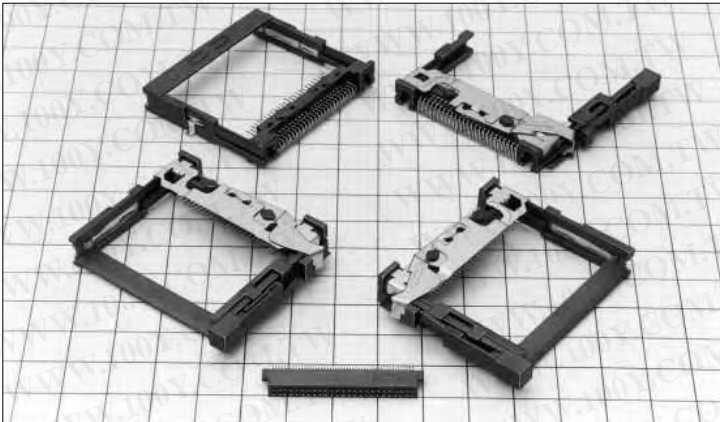

(a) Space-saving design

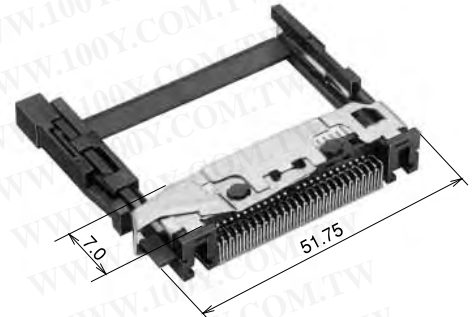

■ Features

1. Compact design occupies minimum space

Connectors are designed with small width and depth for miniaturization and the foot print on the board has been made smaller. (See (a) to the right)

2. Supplied with ground terminals

The MI21 Series are furnished with ground terminals.

3. Card ejection mechanism

Two point ejection mechanism to assure even card ejection.

4. Designed and packaged for board placement with automatic equipment

Headers are designed with a pick up area to accommodate the pick-and -place nozzles of automatic mounting machines. (Patents pending)

Receptacles are designed to be mounted on top the board, and automatic mounting is possible on the specified board.

5. Card ejection mechanism

Available in several termination and mouting styles, with and without ejection mechanism, with and without stand-offs.

6. Rich variations

A rich assortment of variations allows selection of a type to suit the specific card and the equipment to which it will be installed.

- (1) Suitable cards: Type I , type I/II .
- (2) Eject button: None, right , left
- (3) Standoff: 0 mm, 2.2 mm
- (4) Board mounting type: Standard , reverse

(b) Suitable for automatic mounting



HRS Product Feature

Fixed fittings make slider immobile.



Construction facilitates pick-and-place process.

● Product Variation

Series	Mounting	offset	Ejector	Cards	Built-in nuts
MI20	Standard	None	None	Type I or II	—
		2.2mm	Right Left	Type I	YES
	Reverse	2.2mm	None	Type I	φ(Note)
MI21	Standard	None	Right Left	Type I or II	YES
		2.2mm	None		
	Reverse	None	None		

Note 1: Hexagonal nuts (M2×0.4) are required.

勝特力材料 886-3-5753170
 勝特力电子(上海) 86-21-34970699
 勝特力电子(深圳) 86-755-83298787
[Http://www.100y.com.tw](http://www.100y.com.tw)

■ Applications

PDA, digital still cameras, etc.

Product Specifications

Rating	Current rating	0.5 A	Operating temperature range	-20 to +60°C (Note 1)	Storage temperature range	-10 to +60°C (Note 2)
	Voltage rating	125 V AC	Operating humidity range	Relative humidity 95% or less (No condensation)	Storage humidity range	40 to 70% (Note 2)

Item	Specification	Conditions
1. Insulation resistance	1,000 MΩ min.	500 V DC
2. Withstanding voltage	No flashover or insulation breakdown.	500 V AC / 1 minute
3. Contact resistance	40 mΩ max. (initial value) (Note 3)	1 mA
4. Vibration	No electrical discontinuity of 100ns or more	Frequency: 10 to 2000 Hz, full amplitude of 1.52 mm or acceleration of 147 m/s ² (peak), 4 hours in each of the 3 directions.
5. Humidity (Steady state)	Insulation resistance of 100 MΩ min.	96 hours at temperature of 40±2°C and humidity of 90% to 95%
6. Temperature cycle	Insulation resistance of 100 MΩ min.	Temperature: -55°C for 30 min. --> +5 to 35°C within 5 min. 85°C for 30 min. --> +5 to 35°C within 5 min. for 5 cycles
7. Durability (Insertion/withdrawal)	Change of contact resistance from initial value is 20 mΩ max.	10000 cycles at 400 to 600 cycles per hour
8. Resistance to Soldering heat	No deformation of components affecting performance.	Reflow: At the recommended temperature profile Manual soldering: 350°C for 3 seconds

Note 1: Includes temperature rise caused by current flow.

Note 2: The term "storage" refers to products stored for long period of time prior to mounting and use. Operating Temperature Range and Humidity range covers non- conducting condition of installed connectors in storage, shipment or during transportation.

Note 3: This does not include the resistance of the conductor .

Materials

Item	Part	Material	Finish	Remarks
Receptacle	Insulator	PPS	Color : Black	UL94V-0
	Contacts	Phosphor bronze	Contact Area : Gold plating Mounting Area : Gold plating	_____
Header	Insulator	PPS	Color : Black	UL94V-0
	Contacts	Brass	Contact Area : Gold plating Mounting Area : Solder plating	_____
	Metal fitting	Brass	_____	Applied to eject mechanism
	Eject fitting	Stainless steel	_____	_____
	Ground clip	Stainless steel	_____	Applied to MI21 series

Ordering Information

●Receptacles

MI20 - 50 RD - SF (51)

① ② ③ ④ ⑤

① Series name: MI20
② Number of contacts: 50
③ Connector type RD: Receptacle
④ Contact form SF: SMT
⑤ (51): RoHS compliant

●Headers

MI20 A - 50 PD R - SF - EJR (71)

① ② ③ ④ ⑤ ⑥ ⑦ ⑧

① Series name MI20: for type I cards (*) MI21: for type I and II cards	⑤ Board mounting type Blank : Standard R : Reverse
② Stand off type Blank : None A : 2.2 mm	⑥ Contact type SF: SMT
③ Number of contacts: 50	⑦ Eject button position EJR : Right button EJL : Left button Blank : None
④ Connector type PD: Header	⑧ (71) : RoHS compliant

(*) Can accommodate type II cards only when standard mounting is used and stand off is 0 mm.

■ Receptacle

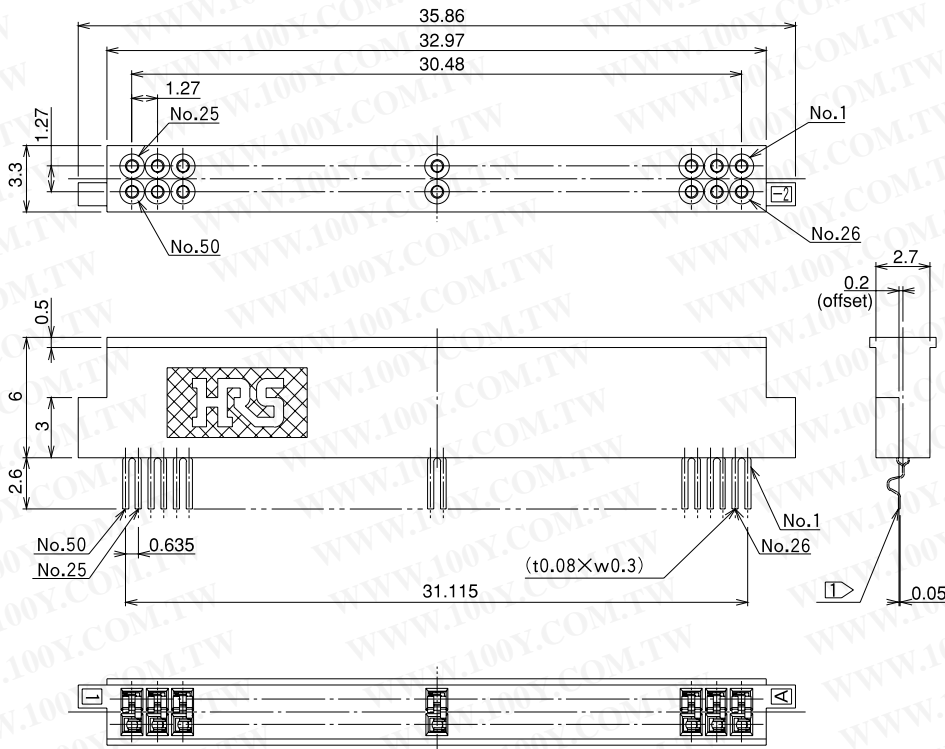

Note 1 The coplanarity of the conductor is 0.1 mm Max.

Part Number	CL No.	Number of Contacts	Packaging	RoHS
MI20-50RD-SF(51)	640-7001-0-51	50	Tray	YES

◆ PCB mounting pattern

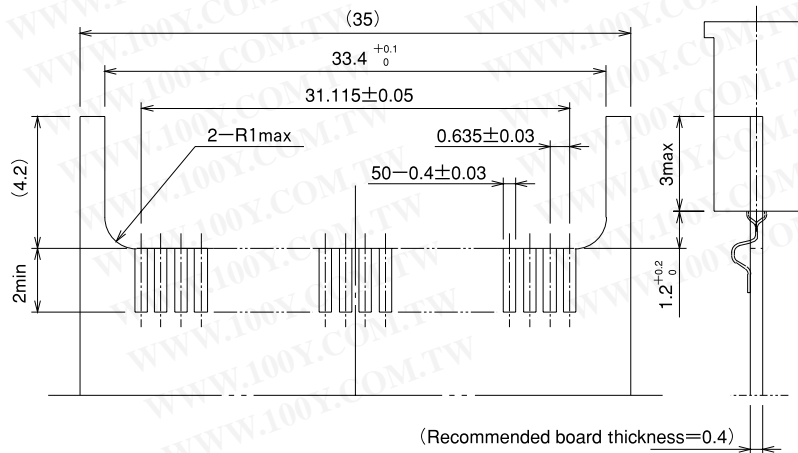

■ Headers for Type I or II Cards

- Eject button : None
- Offset : None
- Mounting style : Standard mounting

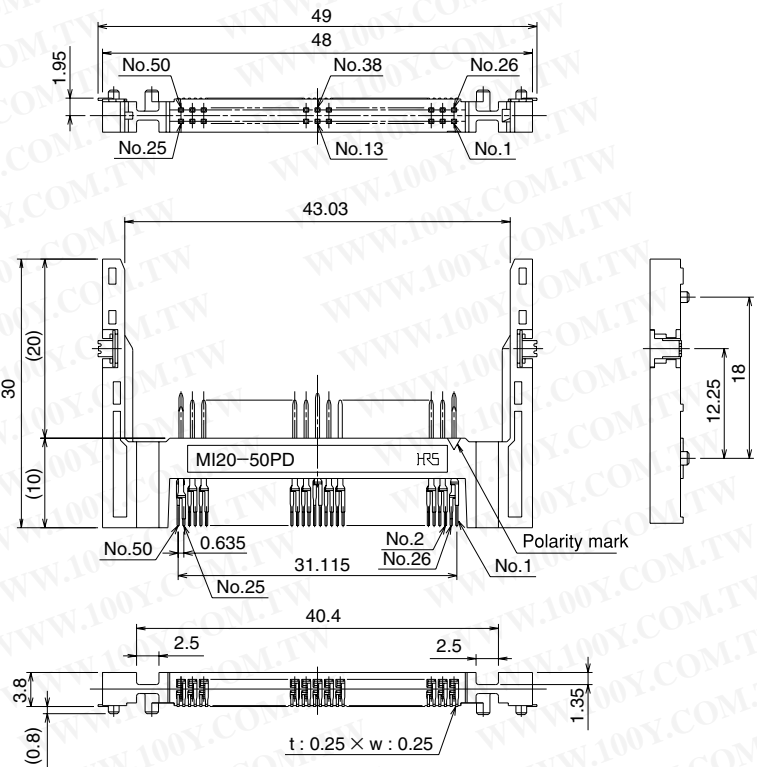

Note 1: Coplanarity of all surface mount terminals and components is 0.1.

Note 2: Dimensions in parentheses () are reference dimensions.

Part Number	CL No.	Number of Contacts	Packaging	RoHS
MI20-50PD-SF(71)	640-7002-2-71	50	Tray	YES

◆ PCB mounting pattern

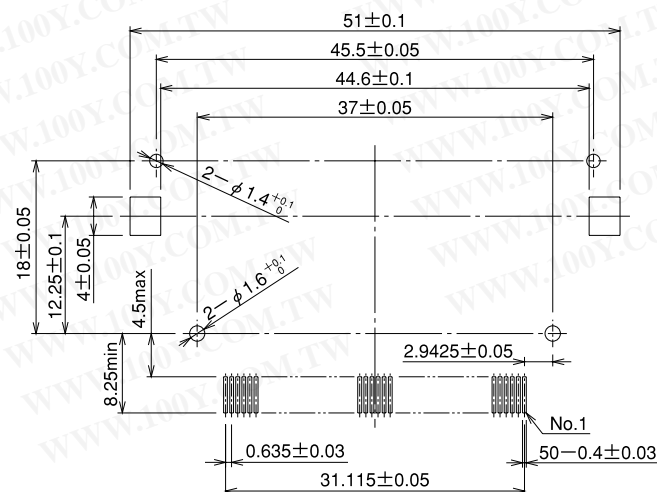

■ Headers for Type I Cards

- Eject button : None
- Offset : 2.2 mm
- Mounting style : Reverse mounting

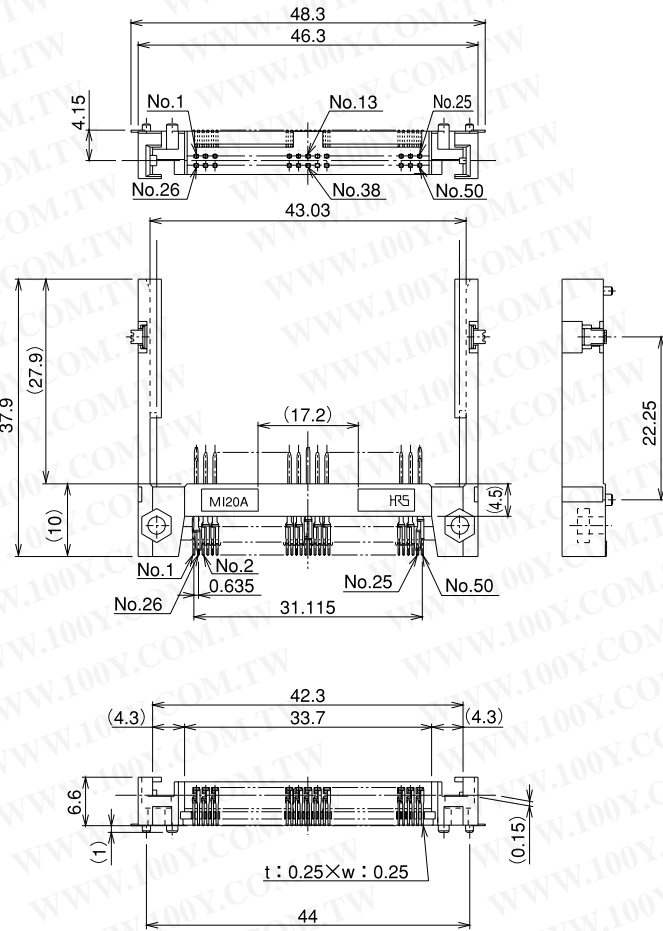

Note 1: Coplanarity of all surface mount terminals and components is 0.1.

Note 2: Dimensions in parentheses () are reference dimensions.

Part Number	CL No.	Number of Contacts	Packaging	RoHS
MI20A-50PDR-SF(71)	640-7003-5-71	50	Tray	YES

◆ PCB mounting pattern

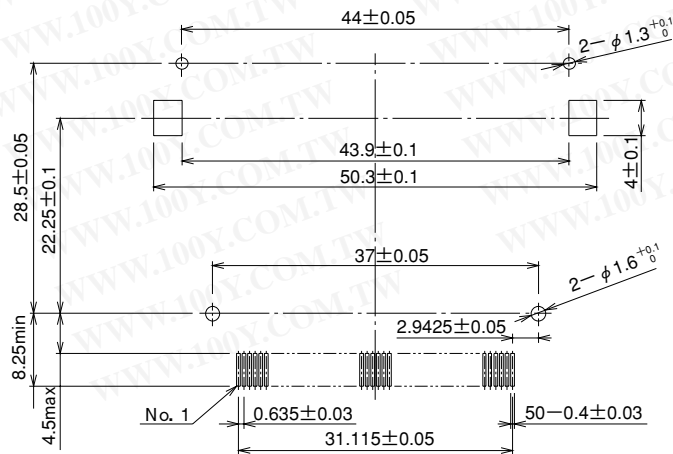

■Headers for Type I Cards

- Eject button : Right button
- Offset : 2.2 mm
- Mounting style : Standard mounting

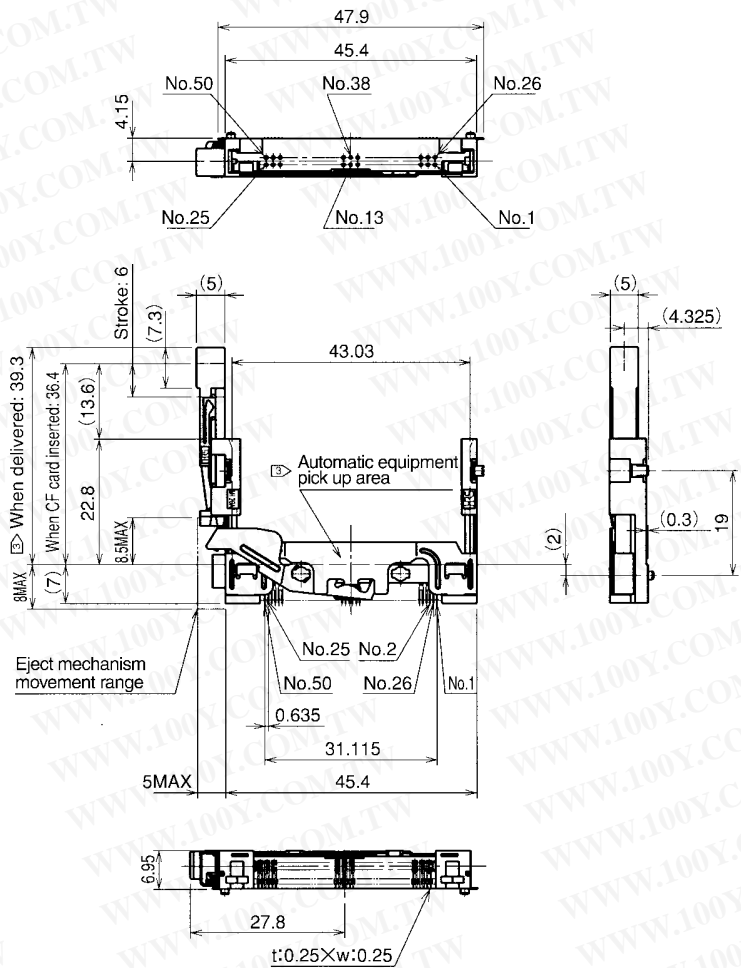

Note 1: The amount of card and button protrusion from the connector after mating is 13.6 mm.

Note 2: The dimensions of mating portion of this product comply with CFA standards.

Note 3: This product can be automatically mounted. The suction surface for automatic mounting is positioned as illustrated in the figure.

③ This part is fixed in the initial condition, but released with a single operation of the ejector.

(Amount of actual card ejection: 3.5 mm)

Note 4: The coplanarity (degree of flatness) of the SMT lead tip portion and the reinforced fitting mounting end face is to be 0.1 maximum.

Note 5: Dimensions in parentheses () are to be regarded as reference dimensions.

Part Number	CL No.	Number of Contacts	Packaging	RoHS
MI20A-50PD-SF-EJR(71)	640-7004-8-71	50	Tray	YES

◆PCB mounting pattern

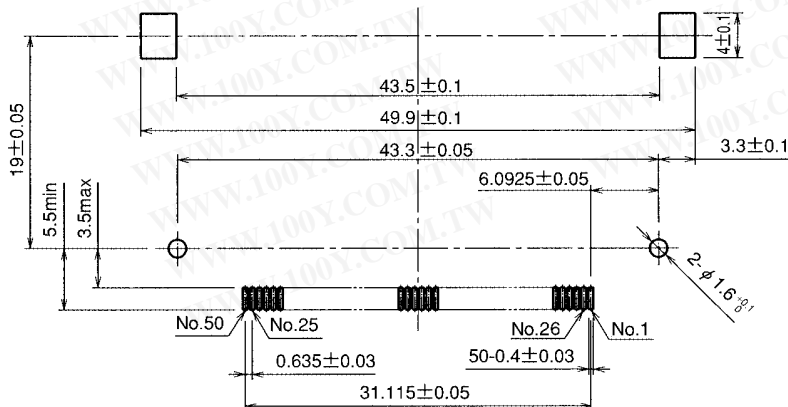

■Headers for Type I Cards

- Eject button : Left side
- Offset : 2.2 mm
- Mounting style : Standard mounting

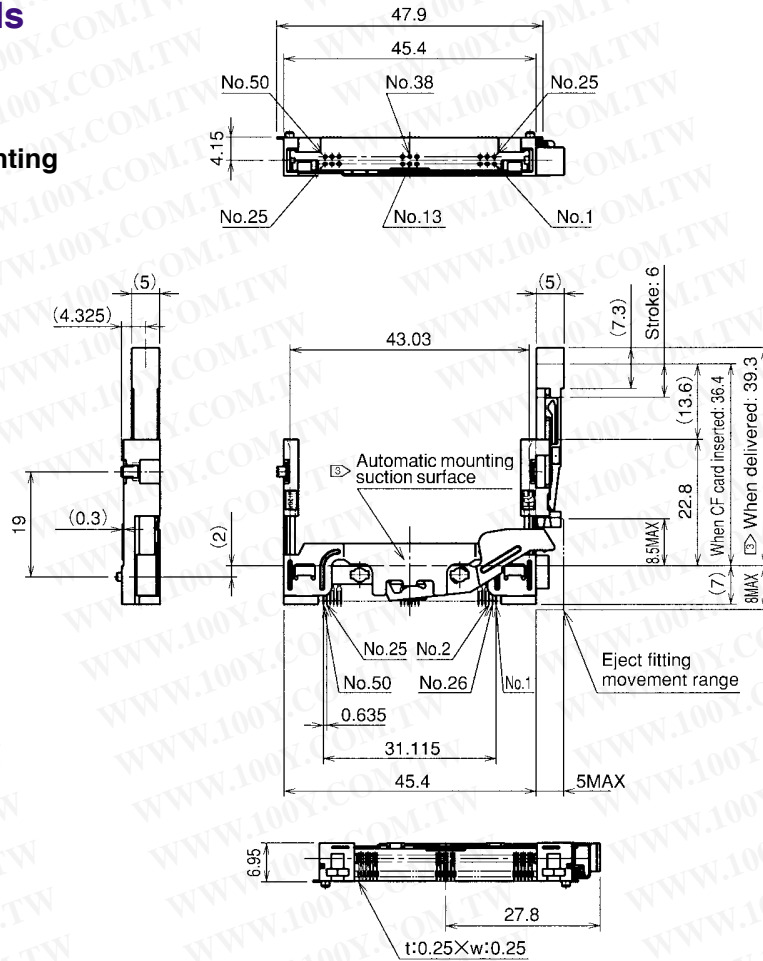

Note 1: The amount of card and button protrusion from the connector after mating is 13.6 mm.

Note 2: The dimensions of mating portion of this product comply with CFA standards.

Note 3: This product can be automatically mounted. The suction surface for automatic mounting is positioned as illustrated in the figure.

③ This part is fixed in the initial condition, but released with a single operation of the ejector.

(Amount of actual card ejection: 3.5 mm)

Note 4: The coplanarity (degree of flatness) of the SMT lead tip portion and the reinforced fitting mounting end face is to be 0.1 maximum.

Note 5: Dimensions in parentheses () are to be regarded as reference dimensions.

Part Number	CL No.	Number of Contacts	Packaging	RoHS
MI20A-50PD-SF-EJL(71)	640-7005-0-71	50	Tray	YES

◆PCB mounting pattern

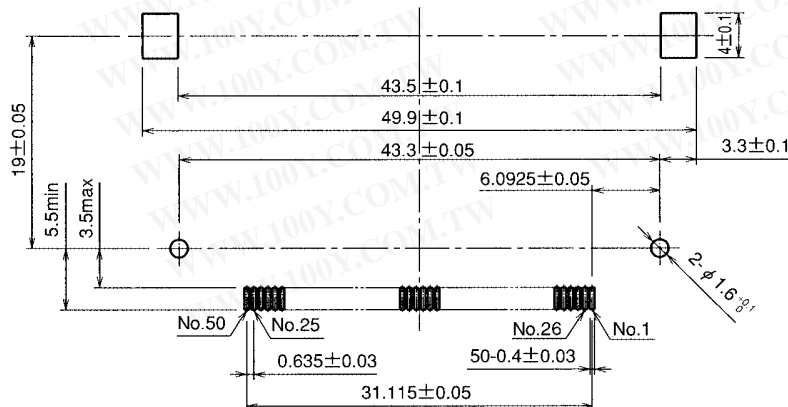

■Headers for Type I or II Cards

- Eject button : Right side
- Offset : 0 mm
- Mounting style : Standard mounting

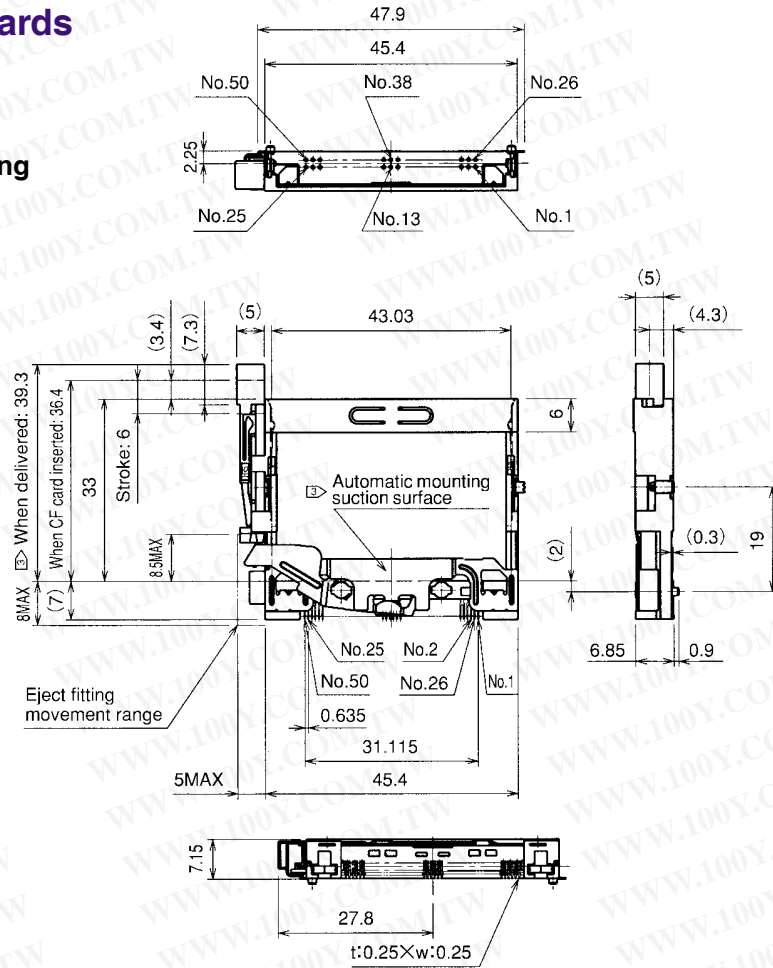

Note 1: This item is a (standard type) header for use with CompactFlash cards.

Note 2: The dimensions of mating portion of this product comply with CFA standards.

Note 3: This product can be automatically mounted. The suction surface for automatic mounting is positioned as illustrated in the figure.

③ This part is fixed in the initial condition, but released with a single operation of the ejector.

(Amount of actual card ejection: 3.5 mm)

Note 4: The coplanarity (degree of flatness) of the SMT lead tip portion and the reinforced fitting mounting end face is to be 0.1 maximum.

Note 5: Dimensions in parentheses () are to be regarded as reference dimensions.

Part Number	CL No.	Number of Contacts	Packaging	RoHS
MI21-50PD-SF-EJR(71)	640-7107-0-71	50	Tray	YES

◆PCB mounting pattern

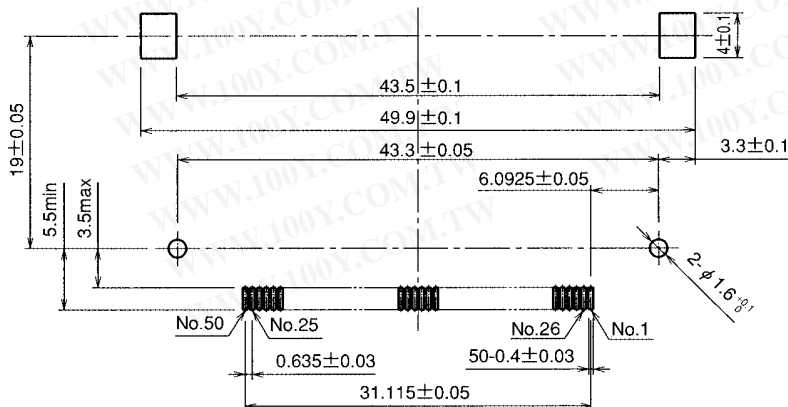

■Headers for Type I or II Cards

- Eject button : Left side
- Offset : None
- Mounting style : Standard mounting

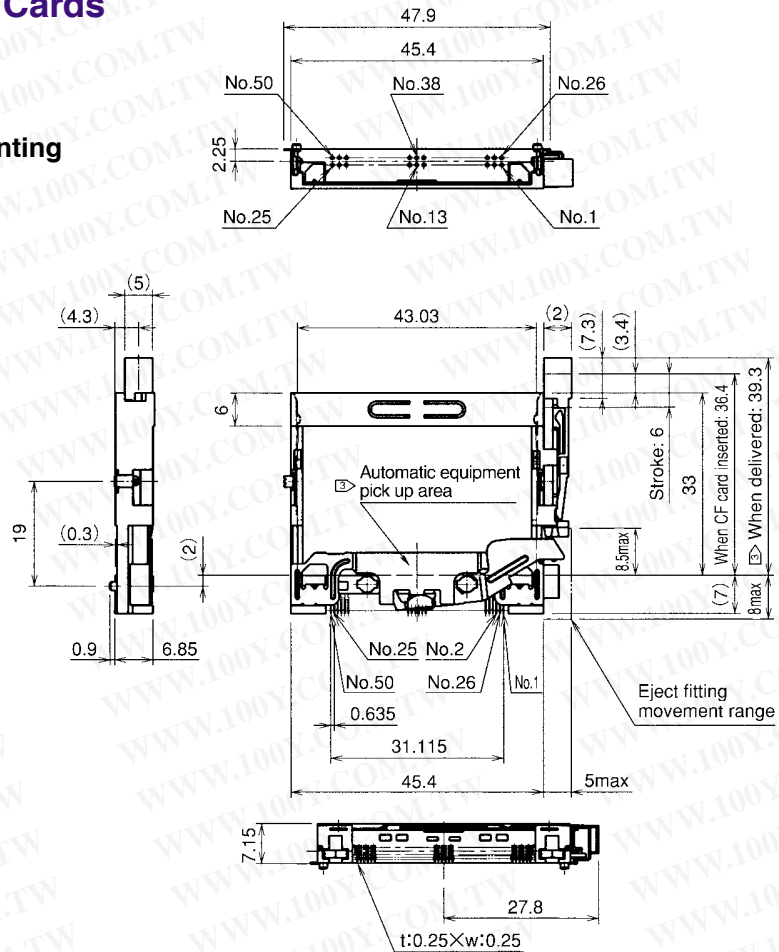

Note 1: This item is a (standard type) header for use with CompactFlash cards.

Note 2: The dimensions of mating portion of this product comply with CFA standards.

Note 3: This product can be automatically mounted. The suction surface for automatic mounting is positioned as illustrated in the figure.

③ This part is fixed in the initial condition, but released with a single operation of the ejector.

(Amount of actual card ejection: 3.5 mm)

Note 4: The coplanarity (degree of flatness) of the SMT lead tip portion and the reinforced fitting mounting end face is to be 0.1 maximum.

Note 5: Dimensions in parentheses () are to be regarded as reference dimensions.

Part Number	CL No.	Number of Contacts	Packaging	RoHS
MI21-50PD-SF-EJL(71)	640-7108-3-71	50	Tray	YES

◆PCB mounting pattern

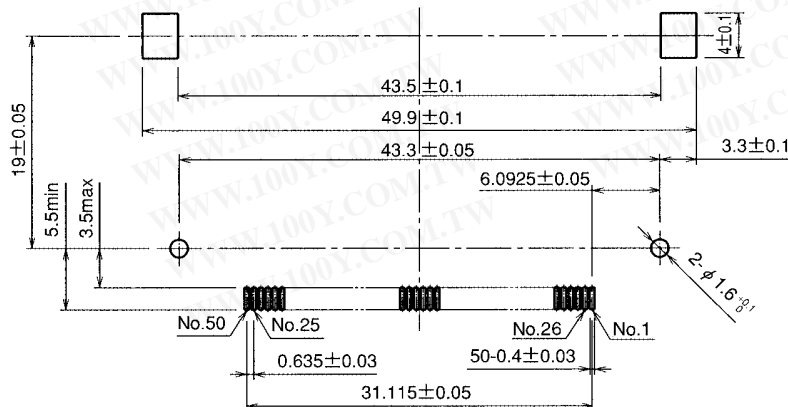

■Headers for Type I or II Cards

- Eject button : None
- Offset : None
- Mounting style : Standard mounting

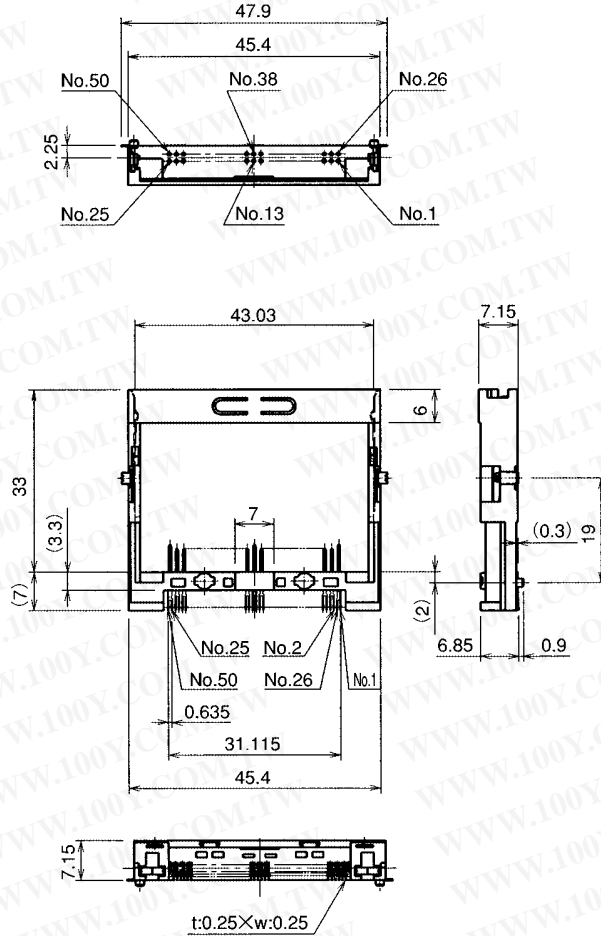

Note 1: This item is a (standard type) header for use with CompactFlash cards.

Note 2: The dimensions of mating portion of this product comply with CFA standards.

Note 3: The coplanarity (degree of flatness) of the SMT lead tip portion and the reinforced fitting mounting end face is to be 0.1 maximum

Note 4: Dimensions in parentheses () are to be regarded as reference dimensions.

Part Number	CL No.	Number of Contacts	Packaging	RoHS
MI21-50PD-SF(71)	640-7109-6-71	50	Tray	YES

◆PCB mounting pattern

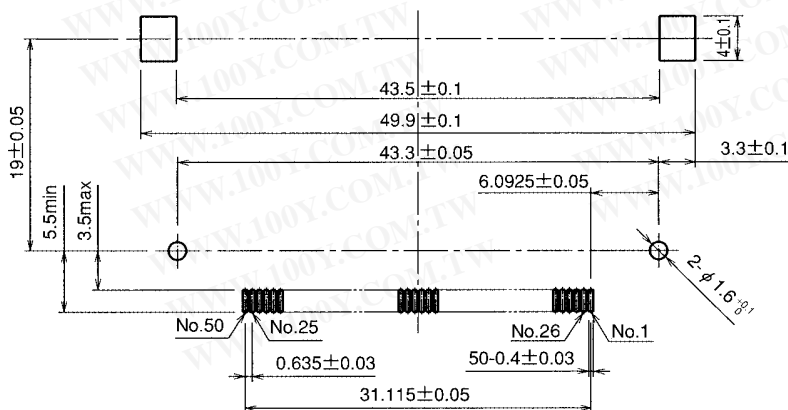

■ Headers for Type I or II Cards

- Eject button : None
- Offset : 0 mm
- Mounting style : Reverse mounting

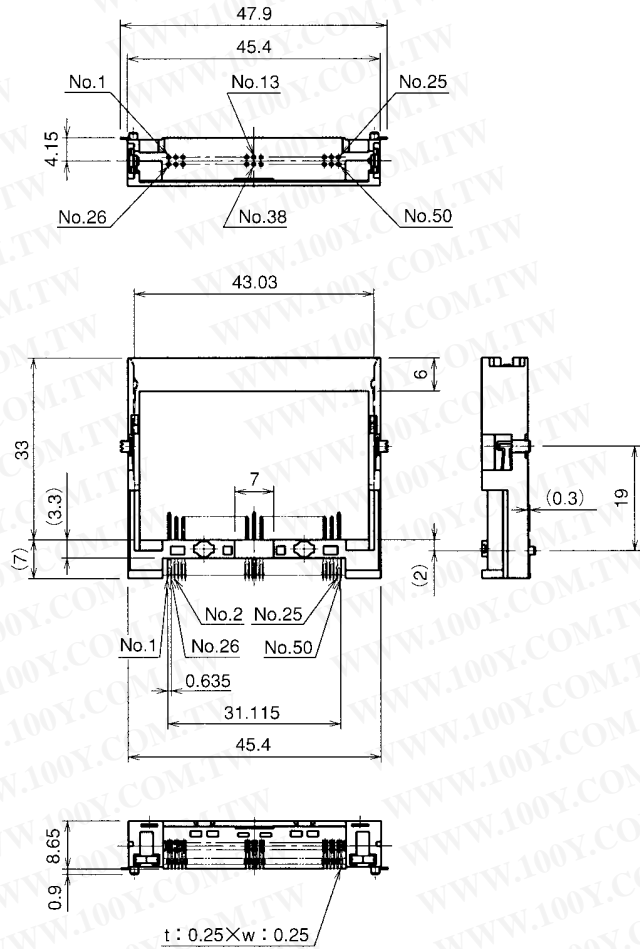

Note 1: Coplanarity of all surface mount terminals and components is 0.1.

Note 2: Dimensions in parentheses () are reference dimensions.

Part Number	CL No.	Number of Contacts	Packaging	RoHS
MI21A-50PDR-SF(71)	640-7106-8-71	50	Tray	YES

◆ PCB mounting pattern

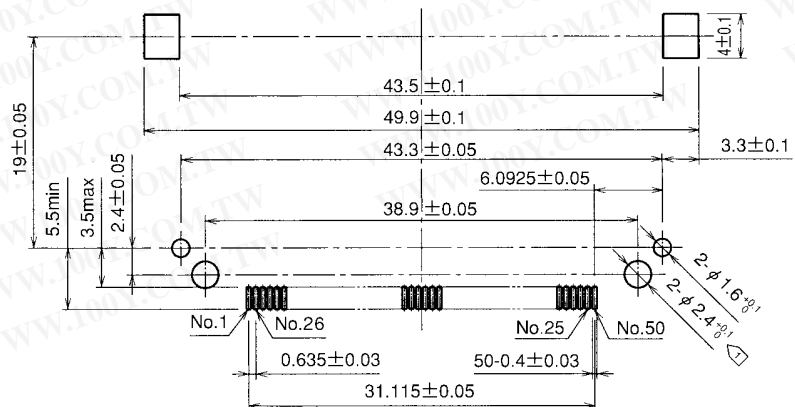

■Headers for Type I and II Cards

- Eject button : Right side
- Offset : 2.2 mm
- Mounting style : Standard mounting

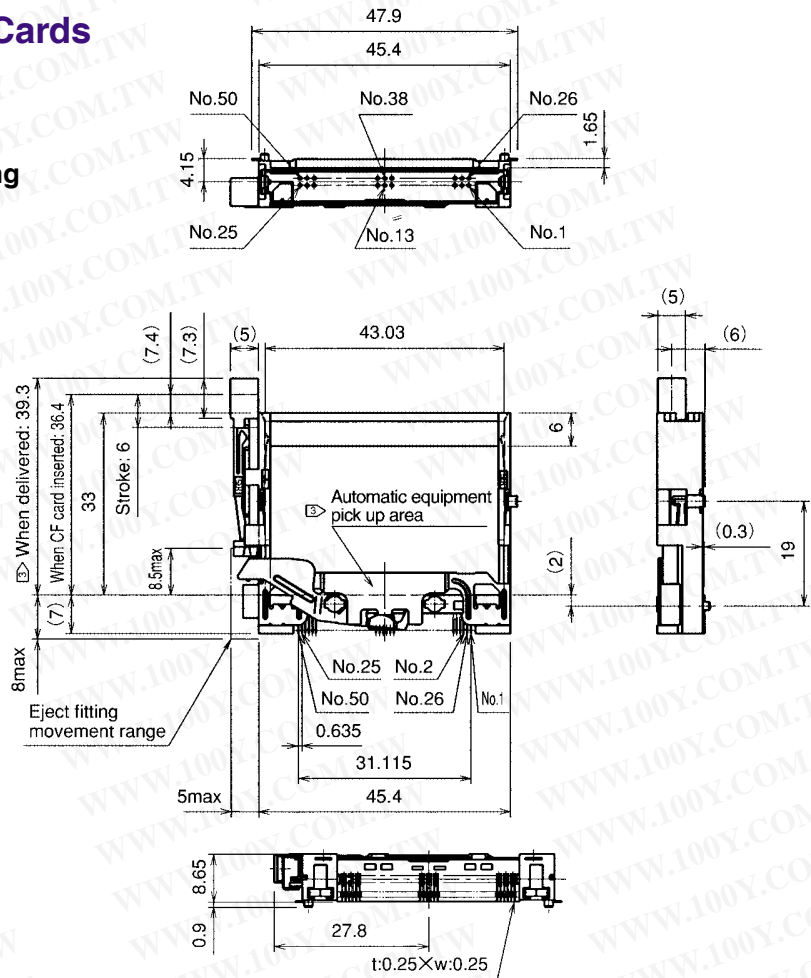

Note 1: This item is a (standard type) header for use with CompactFlash cards.

Note 2: The dimensions of mating portion of this product comply with CFA standards.

Note 3: This product can be automatically mounted. The suction surface for automatic mounting is positioned as illustrated in the figure.

③ This part is fixed in the initial condition, but released with a single operation of the ejector.

(Amount of actual card ejection: 3.5 mm)

Note 4: The coplanarity (degree of flatness) of the SMT lead tip portion and the reinforced fitting mounting end face is to be 0.1 maximum.

Note 5: Dimensions in parentheses () are to be regarded as reference dimensions.

Part Number	CL No.	Number of Contacts	Packaging	RoHS
MI21A-50PD-SF-EJR(71)	640-7101-4-71	50	Tray	YES

◆PCB mounting pattern

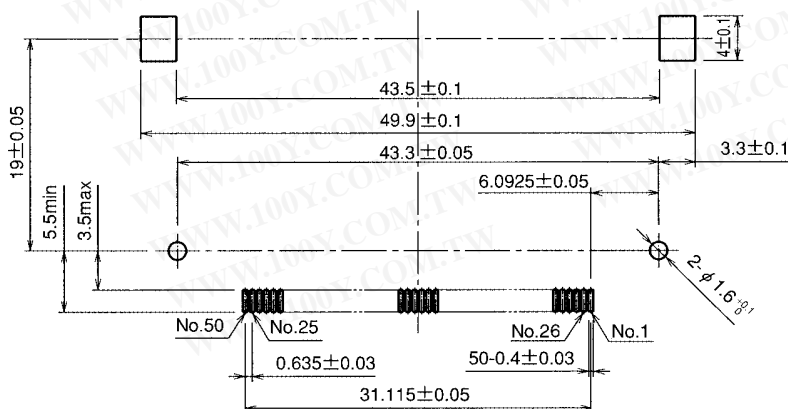

■Headers for Type I and II Cards

- Eject button : Left button
- Offset : 2.2 mm
- Mounting style : Standard mounting

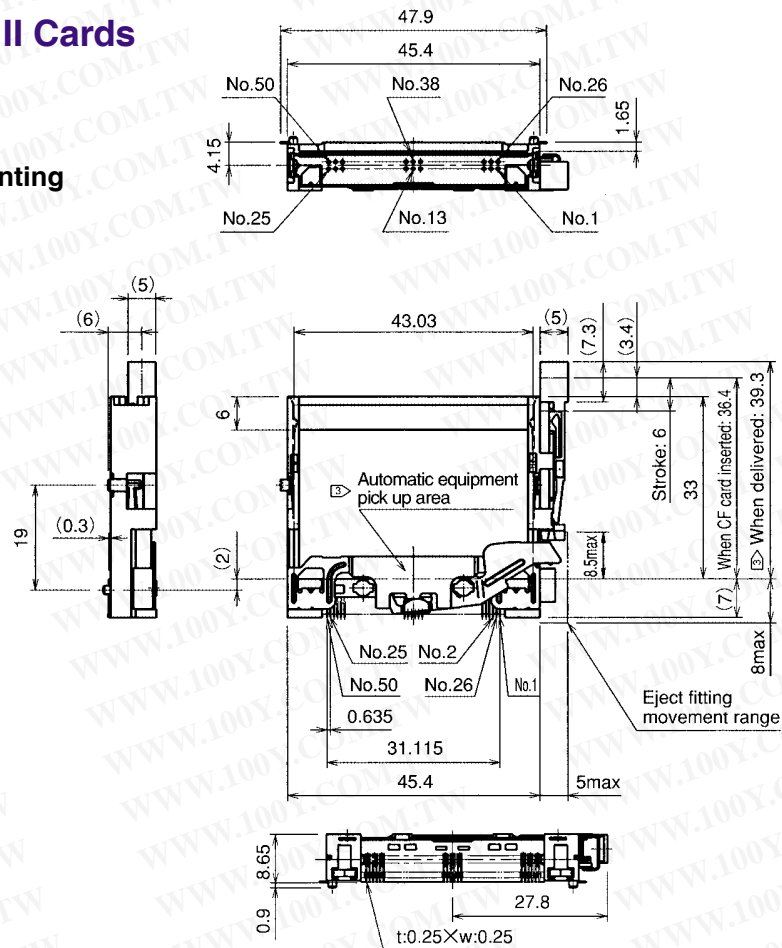

Note 1: This item is a (standard type) header for use with CompactFlash cards.

Note 2: The dimensions of mating portion of this product comply with CFA standards.

Note 3: This product can be automatically mounted. The suction surface for automatic mounting is positioned as illustrated in the figure.

③ This part is fixed in the initial condition, but released with a single operation of the ejector.

(Amount of actual card ejection: 3.5 mm)

Note 4: The coplanarity (degree of flatness) of the SMT lead tip portion and the reinforced fitting mounting end face is to be 0.1 maximum.

Note 5: Dimensions in parentheses () are to be regarded as reference dimensions.

Part Number	CL No.	Number of Contacts	Packaging	RoHS
MI21A-50PD-SF-EJL(71)	640-7102-7-71	50	Tray	YES

◆PCB mounting pattern

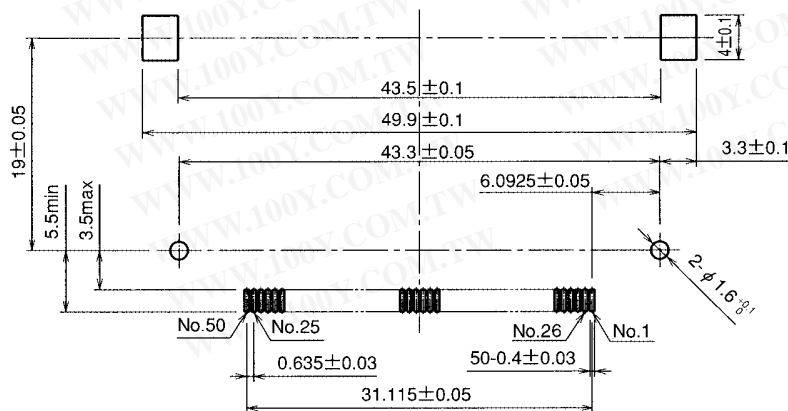

■ Headers for Type I and II Cards

- Eject button : None
- Offset : 2.2 mm
- Mounting style : Standard mounting

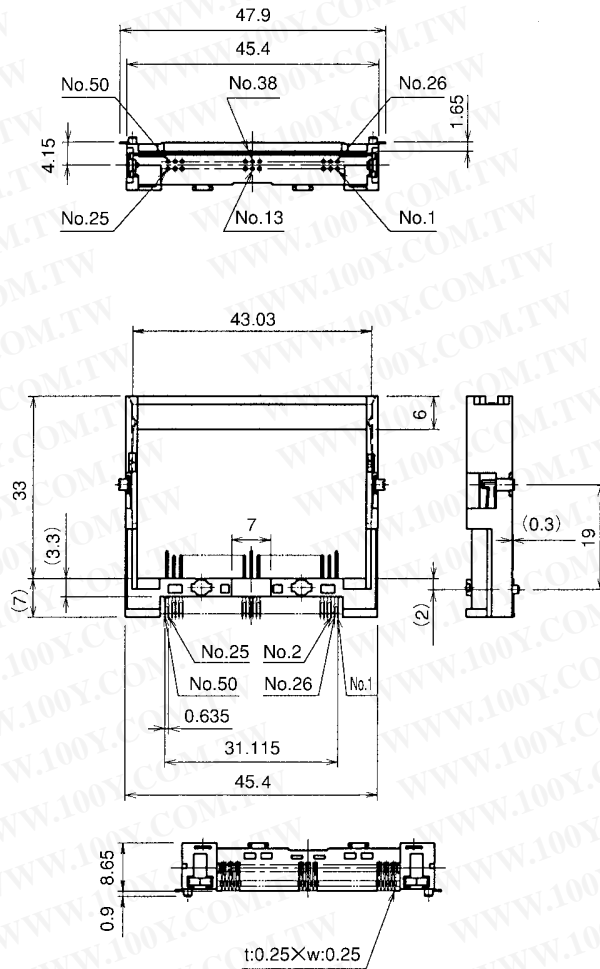

Note 1: Coplanarity of all surface mount terminals and components is 0.1.

Note 2: Dimensions in parentheses () are reference dimensions.

Part Number	CL No.	Number of Contacts	Packaging	RoHS
MI21A-50PD-SF(71)	640-7103-0-71	50	Tray	YES

◆ PCB mounting pattern

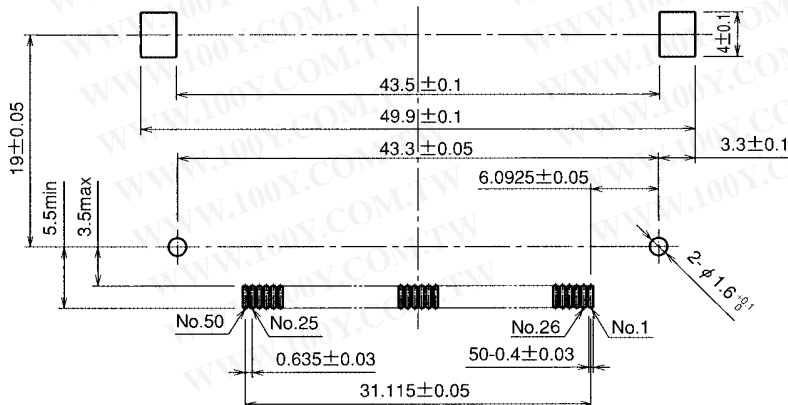

◆ Temperature Profile

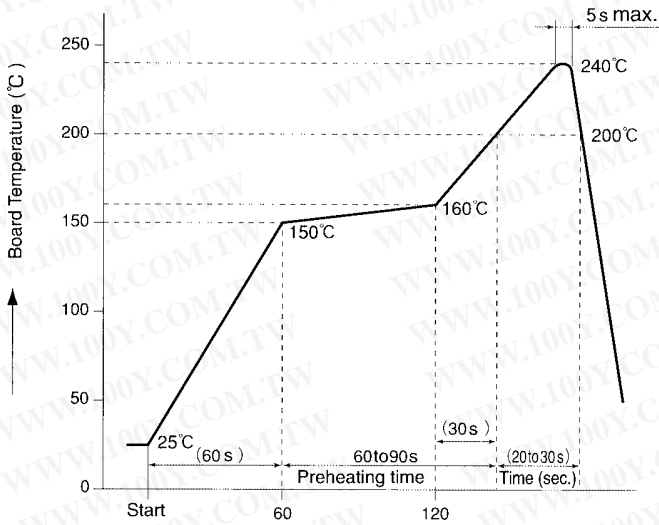

Applicable Conditions

Reflow system : IR reflow

Solde : Paste type 96.5% Sn / 3.0% Ag / 0.5% Cu

Test board Glass epoxy 60mm x 60mm x 1.6 mm

Metal mask thickness: 0.15 mm

Recommended temperature profile.

The temperature may be slightly changed according to the solder paste type and amount.

◆Precautions for Use

1. Differentiate the side of the card at the time of CF card insertion. This product is furnished with a wrong insertion prevention mechanism which is compliant with CFA standards, but forced wrong insertion of the card may cause damage to the card.
2. Do not move the CF card up and down when it has been partially inserted. It may cause damage to the connector and card.

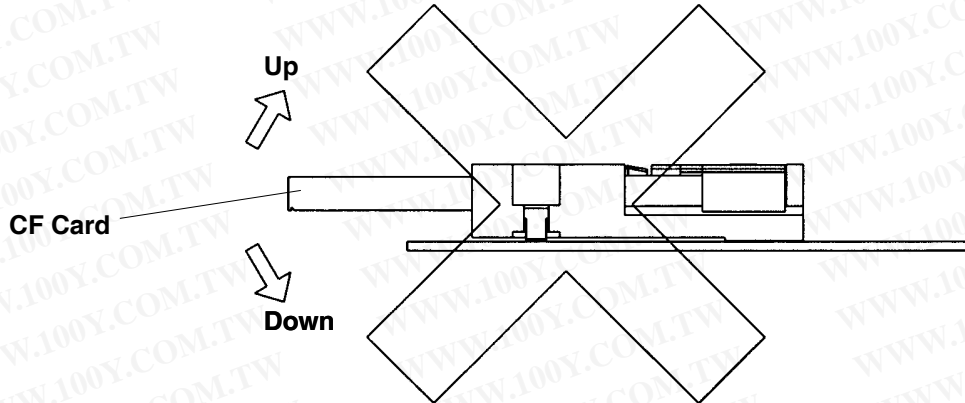

3. The package used for this product is the soft tray. We recommend a check before mounting, since the adjustment may be required depending on the type of moulder. For more detailed information, please contact nearest Hirose account representative.

◆Washing Conditions

This product is a no-wash item, but in the case of washing, please observe the following conditions.

1. Organic Solvent Washing

Solvent	Room temperature washing	Heated washing
IPA (Isopropyl alcohol)	YES	YES
HCFC (Hydrochlorofluorocarbon)	YES	YES

2. Water Type Washing

When using water type cleaning agents (e.g., terpene, and alkali saponifiers), select the cleaning agent based on the documentation issued by the various manufacturers of cleaning agents which describes the effects on metals and resins.

Be careful that parts are not left with moisture remaining on them.

3. Washing Precautions

Residual flux or cleaning agent on the contacts when washing with organic solvents or water type cleaners can give rise to the deterioration of electrical performance. In this regard it is important to check whether a thorough washing has been performed.

勝特力材料 886-3-5753170
勝特力电子(上海) 86-21-34970699
勝特力电子(深圳) 86-755-83298787
[Http://www.100y.com.tw](http://www.100y.com.tw)