

**0.8 mm Pitch**



**Connectors**

# HDRA series

**0.8 mm Pitch Connectors**

勝特力材料 886-3-5753170  
勝特力电子(上海) 86-21-34970699  
勝特力电子(深圳) 86-755-83298787  
[Http://www.100y.com.tw](http://www.100y.com.tw)

## Outline

HDRA series connectors have been developed based on the HDR series products for high speed signal interfaces such as SCSI-III, VHDCI and PCI.

## Features

- Conforms to the United States ANSI/SFF8441 standards
- Provided with high performance EMI/ESD-shielded structure
- Mounted with locks or screws
- Low profile
- Sequence structure

## Principal Applications

Server, Router, Notebook type personal computers and their peripheral equipment, and mobile equipment

## Electrical Characteristics

Rated voltage	30V AC (r.m.s.)
Rated current	0.3 A
Insulation resistance	Over 500 megohms at 100V DC
Dielectric withstanding voltage	250V AC (r.m.s.)
Contact resistance	70 milliohms or less (for combination of MA or MA1 and LFDT) 100 milliohms or less (for combination with MA1 and W1LFDT)

### Document Disclaimer

- When placing orders with us, minimum order quantities are set for every product.
- Be sure to contact us before starting preliminary design of PCBs using our connectors.
- The specifications and information shown in the catalog are subject to change without notice.

### Reflow temperature profile (for reference purposes)

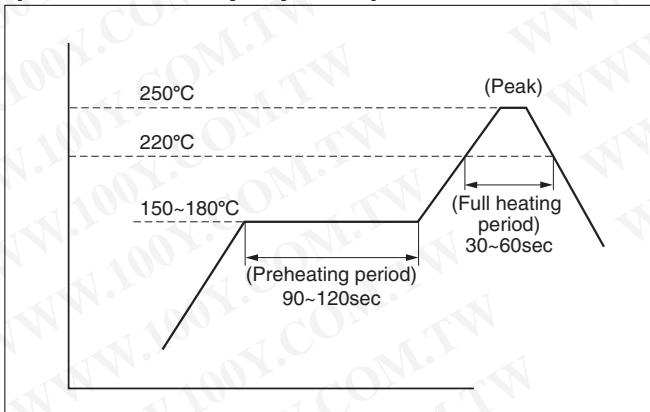

The reflow temperature profile shown in this drawing is for reference purposes. This profile depends on requirements such as reflow equipment, soldering paste, and PCB size. Thus, this profile may not meet with your specific situation. Please evaluate your PCB-mounting soldering and set your own reflow temperature profile.

#### ●Applicable products

HDRA series SMT type for PCB

### Flow temperature profile (for reference purposes)

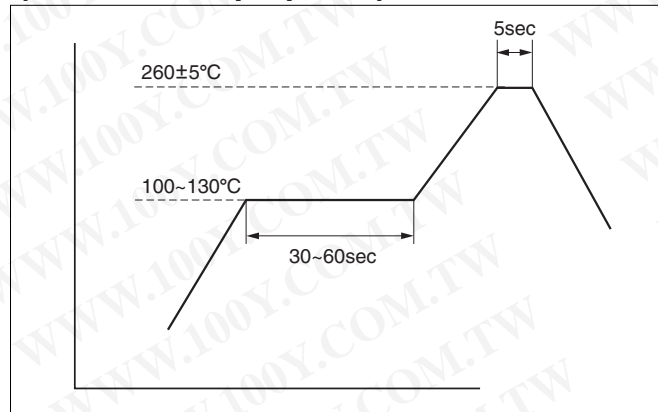

The flow temperature profile as shown above is for reference purposes. This profile depends on requirements such as the PCB size. Thus, this profile may not meet with your specific situation. Please evaluate your PCB-mounting soldering and set your own flow temperature profile.

#### ●Applicable products

HDRA series through hole type for PCB

# Product List

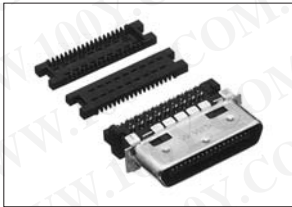

IDC type male connector for cable  
HDRA-E36MA+

**A-22**  
HDRA series...6



IDC type male connector for cable  
HDRA-E68MA+

**A-23**  
HDRA series...7



IDC type male connector for cable  
HDRA-E68M( )+

**A-24**  
HDRA series...8



IDC type male connector for cable  
HDRA-E100M( )+

**A-25**  
HDRA series...9

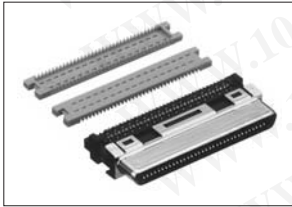

IDC type female connector for cable  
HDRA-E68FAG1+

**A-26**  
HDRA series...10



Straddle SMT type male connector for PCB  
HDRA-E68MT+

**A-27**  
HDRA series...11



Straight through hole type male connector for PCB  
HDRA-EC100MDT( )+

**A-28**  
HDRA series...12



Straight through hole type female connector for PCB  
HDRA-EC68FDT+

**A-29**  
HDRA series...13



Straight through hole type female connector for PCB  
HDRA-EC100FDT+

**A-30**  
HDRA series...14



Right-angle through hole type female connector for PCB  
HDRA-E68LFDT-OM18+

**A-31**  
HDRA series...15



Right-angle through hole type female connector for PCB  
HDRA-E68LFD1T( )+

**A-32**  
HDRA series...16



Right-angle through hole type female connector for PCB  
HDRA-EC68LFDT( )-( )+

**A-33**  
HDRA series...17



Right-angle through hole type female connector for PCB  
HDRA-EC100LFDT( )-( )+

**A-34**  
HDRA series...18



Right-angle through hole type female connector for PCB  
HDRA-EA36LFDT( )+

**A-35**  
HDRA series...19



Right-angle through hole type female connector for PCB  
HDRA-E100LFDT( )-( )+

**A-36**  
HDRA series...20

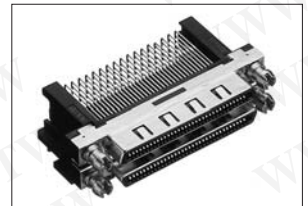

Right-angle through hole type female connector for PCB  
HDRA-E68W1LFDT( )-( )+

**A-37**  
HDRA series...21



Right-angle through hole type female connector for PCB  
HDRA-E68W( )LFD11EC( )+

**A-38**  
HDRA series...22

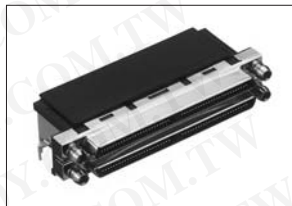

Right-angle through hole type female connector for PCB  
HDRA-E100W( )LFD11EC( )+

**A-39**  
HDRA series...23

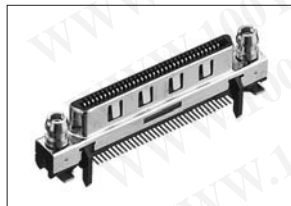

Straight SMT type female connector for PCB  
HDRA-E68FYT( )+

**A-40**  
HDRA series...24

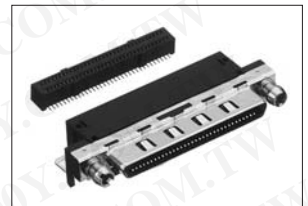

Right-angle SMT type female connector for PCB  
HDRA-ED68LFZGT( )-( )+

**A-41**  
HDRA series...25



Right-angle SMT type female connector for PCB  
HDRA-ED136LFZGT( )-( )+

**A-48**  
HDRA series...26

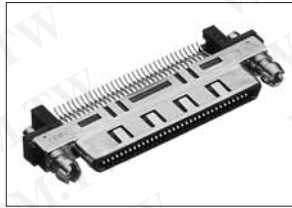

Straddle SMT type female connector for PCB  
HDRA-E68FT+

**A-49**  
HDRA series...27

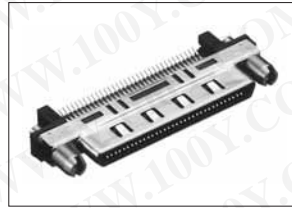

Straddle SMT type female connector for PCB  
HDRA-E68FT2-( )+

**A-50**  
HDRA series...28

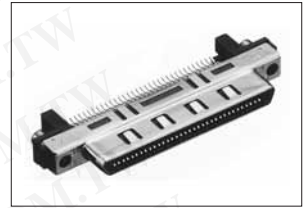

Straddle SMT type female connector for PCB  
HDRA-E68FT2-OM06+

**A-51**  
HDRA series...29



Straddle SMT type female connector for PCB  
HDRA-EA36FT-NS+

**A-52**  
HDRA series...30



EMI-shielded vertical plastic housing for standard cable  
HDRA-E68LGKP( )

**A-53**  
HDRA series...31



EMI-filtered vertical metallic housing  
HDRA-E100LPA

**A-54**  
HDRA series...32



EMI-filtered vertical metallic housing  
HDRA-E100LPW( )

**A-55**  
HDRA series...33



EMI-shielded vertical plastic housing  
HDRA-E36LPTH

**A-56**  
HDRA series...34

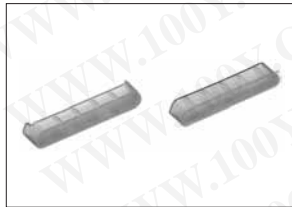

Dust-proof cap  
HDRA-E68( )-CP

**A-57**  
HDRA series...35

IDC type male connector for cable  
**HDRA-E36MA+**

For cable

IDC

RoHS

ANSI/SFF8441



● Configuration of product Part No.

**HDRA- E 36 MA+**

- ① Series name
- ② No. of contacts: 36
- ③ Type of contact  
M: IDC type, male
- ④ Compatible cable  
A: AWG#30(7/0.1), dia. 0.58 mm

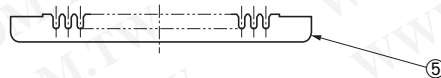
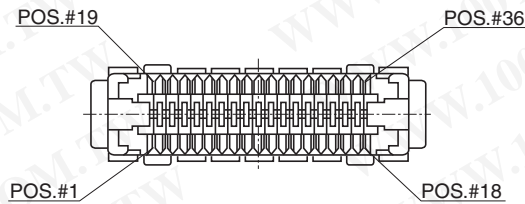
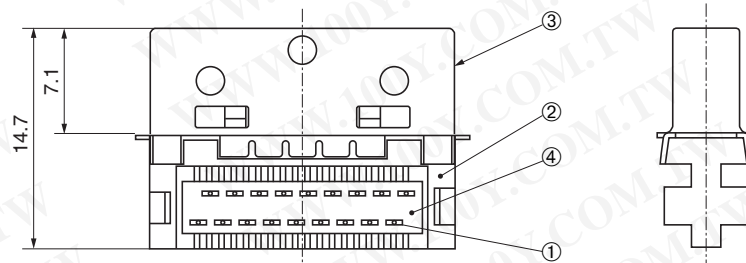
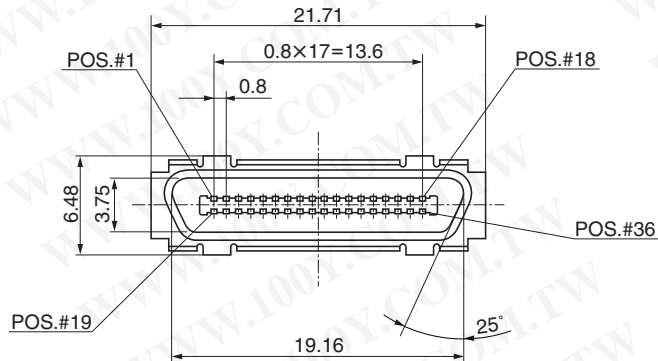

● Components

①	Contacts
②	Insulator
③	Shell
④	Spacer
⑤	Cable housing

**Mating connector:** HDRA series right-angle through hole type or straddle SMT type female connector

**For use with housings:** HDRA series upright housing, HDRA-E36LPTH

IDC type male connector for cable  
HDRA-E68MA+

For cable

IDC

RoHS

ANSI/SFF8441



● Configuration of product Part No.

**HDRA- E 68 MA+**

- ① Series name
- ② No. of contacts: 68
- ③ Type of contact  
M: IDC type, male
- ④ Compatible cable  
A: AWG#30 (7/0.1), dia. 0.58 mm

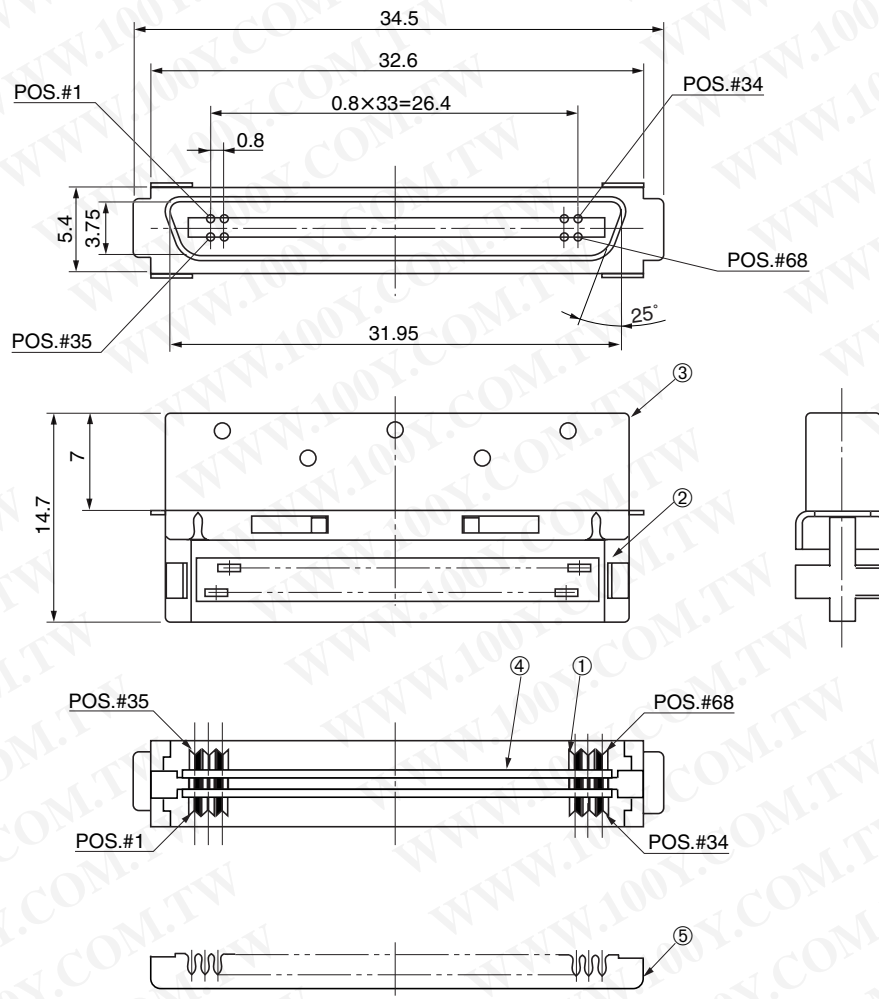

● Components

- ① Contacts
- ② Insulator
- ③ Shell
- ④ Spacer
- ⑤ Cable housing

Mating connector: HDRA series right-angle through hole type or straddle SMT type female connector

For use with housings: HDRA series upright housing, HDRA-E68LGKPA



IDC type male connector for cable  
 HDRA-E100M( )1+

For cable

IDC

ANSI/SFF8441

RoHS



● Configuration of product Part No.

**HDRA- E 100 M ( ) 1+**

- ① Series name
- ② No. of contacts: 100
- ③ Type of contact  
M: IDC type, male
- ④ Compatible cable  
Blank: AWG#30 (1/0.254), dia. 0.58 mm  
A : AWG#30 (7/0.1), dia. 0.58 mm

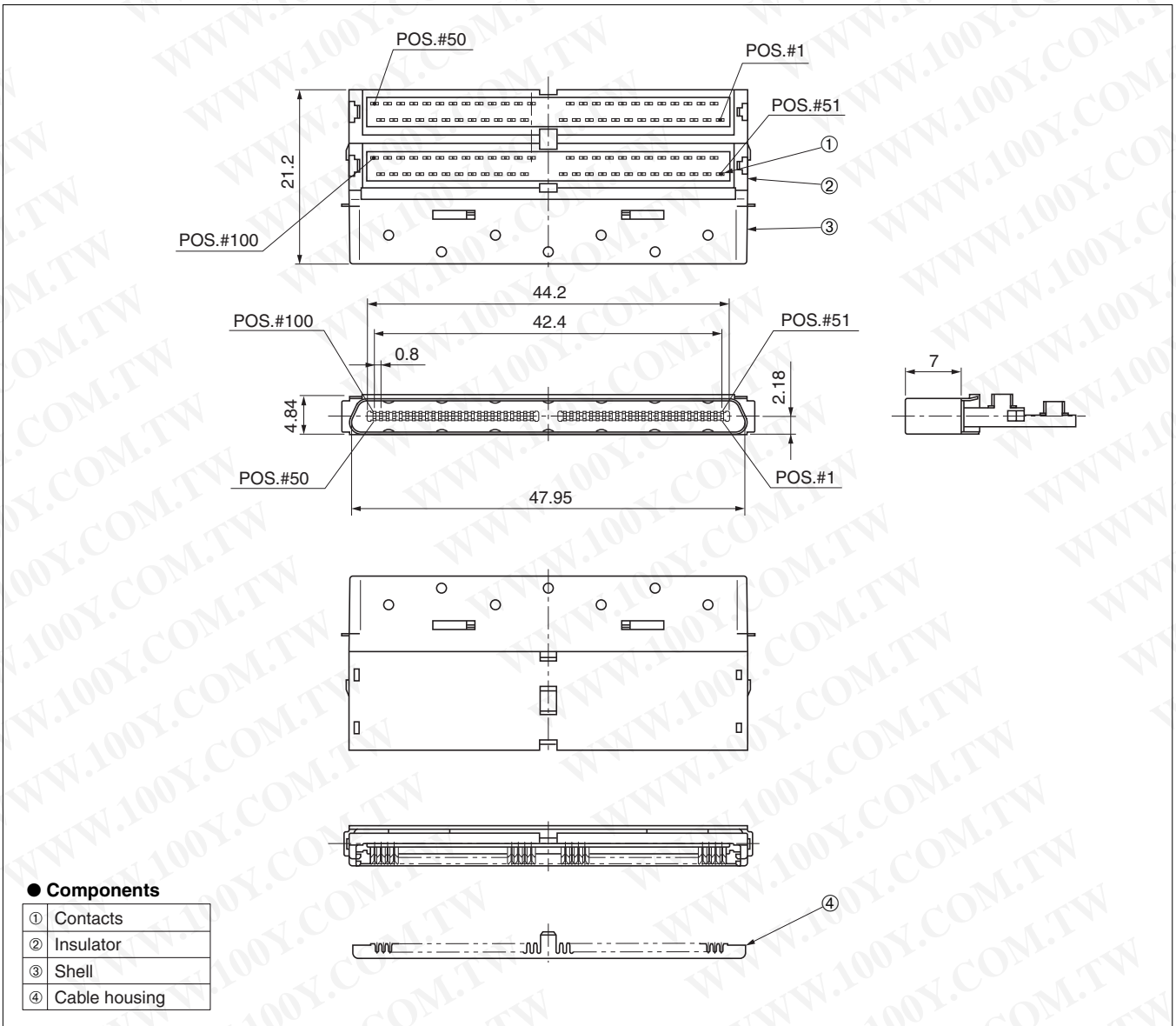

● Components

①	Contacts
②	Insulator
③	Shell
④	Cable housing

Mating connector: HDRA series right-angle through hole type female connector

For use with housings: HDRA series vertical housing, HDRA-E100LPA, HDRA-E100LPW( )

Required tool: Termination tool: FHAT-0038A, IDC tool: FLPT-0021A, Hand presser: RPS-K4 (Refer to page Tool-10)

IDC type female connector for cable  
**HDRA-E68FAG1+**

For cable

IDC

RoHS

ANSI/SFF8441



● Configuration of product Part No.

**HDRA- E 68 F A G1+**

- ① Series name
- ② No. of contacts: 68
- ③ Type of contact  
F: IDC type, female
- ④ Compatible cable  
A: AWG#30 (7/0.1), dia. 0.58 mm
- ⑤ Contact plating  
G1: 0.76 μm or more Gold plate

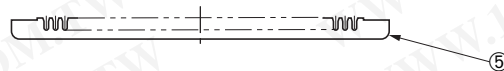
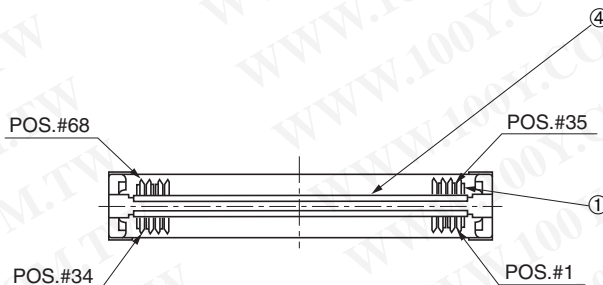
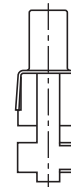
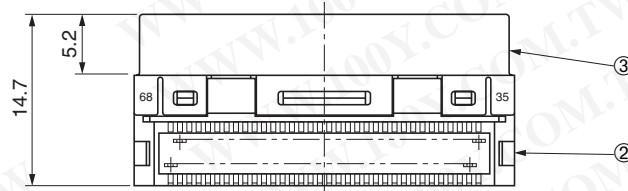
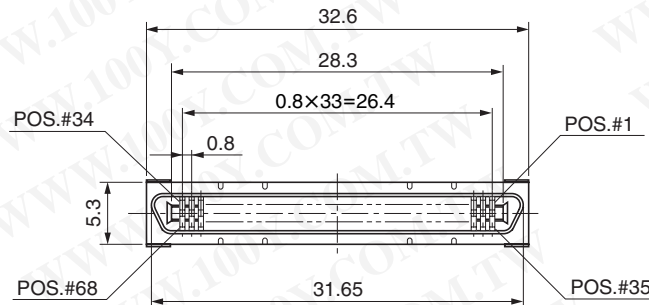

● Components

①	Contacts
②	Insulator
③	Shell
④	Spacers
⑤	Cable housing

Mating connector: HDRA series right-angle through hole type or straddle SMT type male connector

Straddle SMT type male connector for PCB  
HDRA-E68MT+

For PCB

Straddle SMT

ANSI/SFF8441

RoHS



● Configuration of product Part No.

**HDRA- E 68 MT+**

- ① Series name
- ② No. of contacts: 68
- ③ Type of contact  
MT: Straddle SMT type, male

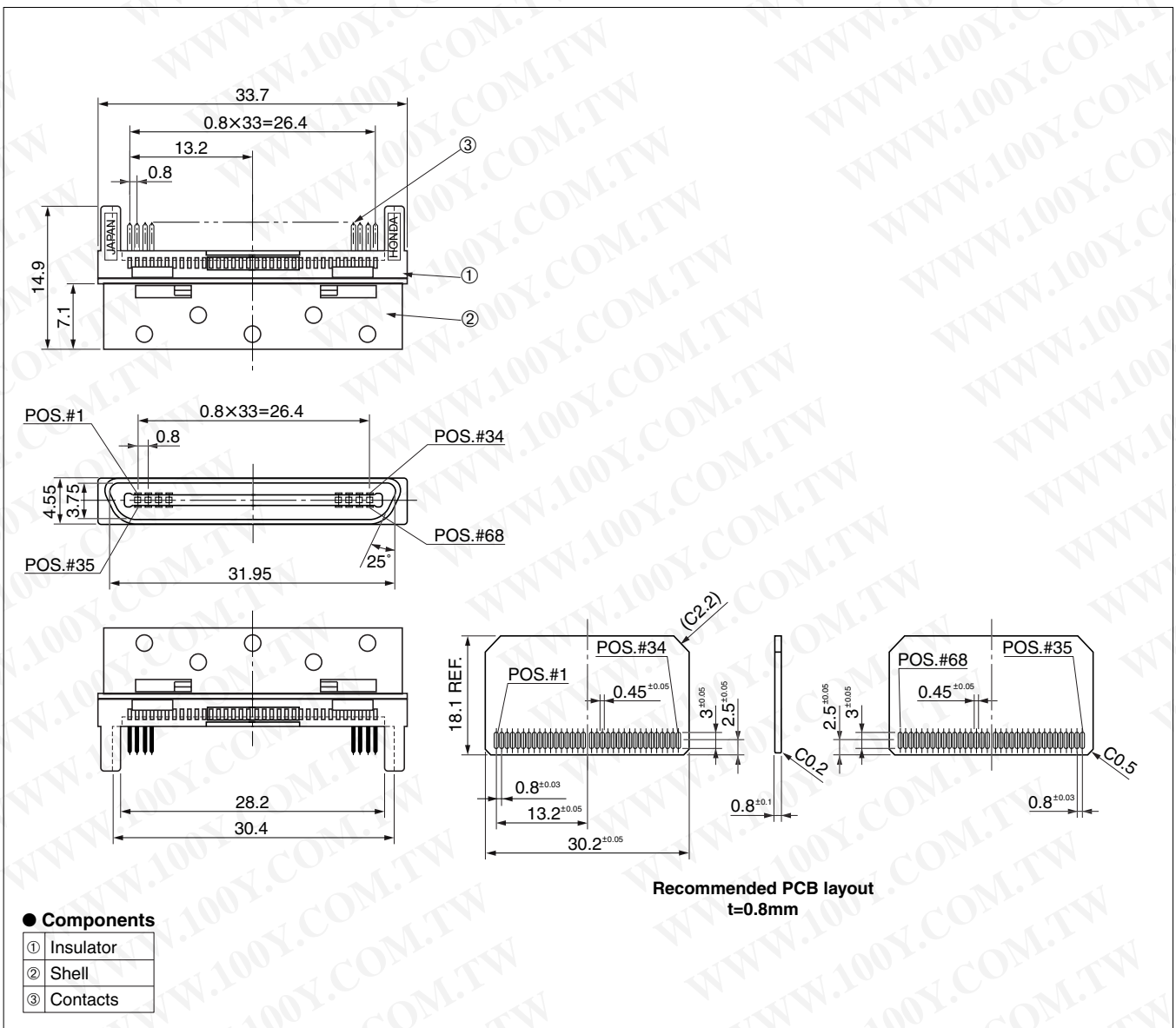

● Components

- ① Insulator
- ② Shell
- ③ Contacts

Mating connector: HDRA series through hole type or straddle SMT type female connector

# Straight through hole type male connector for PCB HDRA-EC100MDT-( )+

For PCB

Straight Through hole

RoHS

EMI shielded



● Configuration of product Part No.

## HDRA- EC 100 MD T- ( )+

- ① Series name
- ② No. of contacts: 100
- ③ Type of contact  
MD: Straight through hole type, male
- ④ With ground contact  
Blank: None  
GP : Provided with guide hardware.  
(The guide pin is required for the mating connector.)
- ⑤ Presence of guide metal fittings

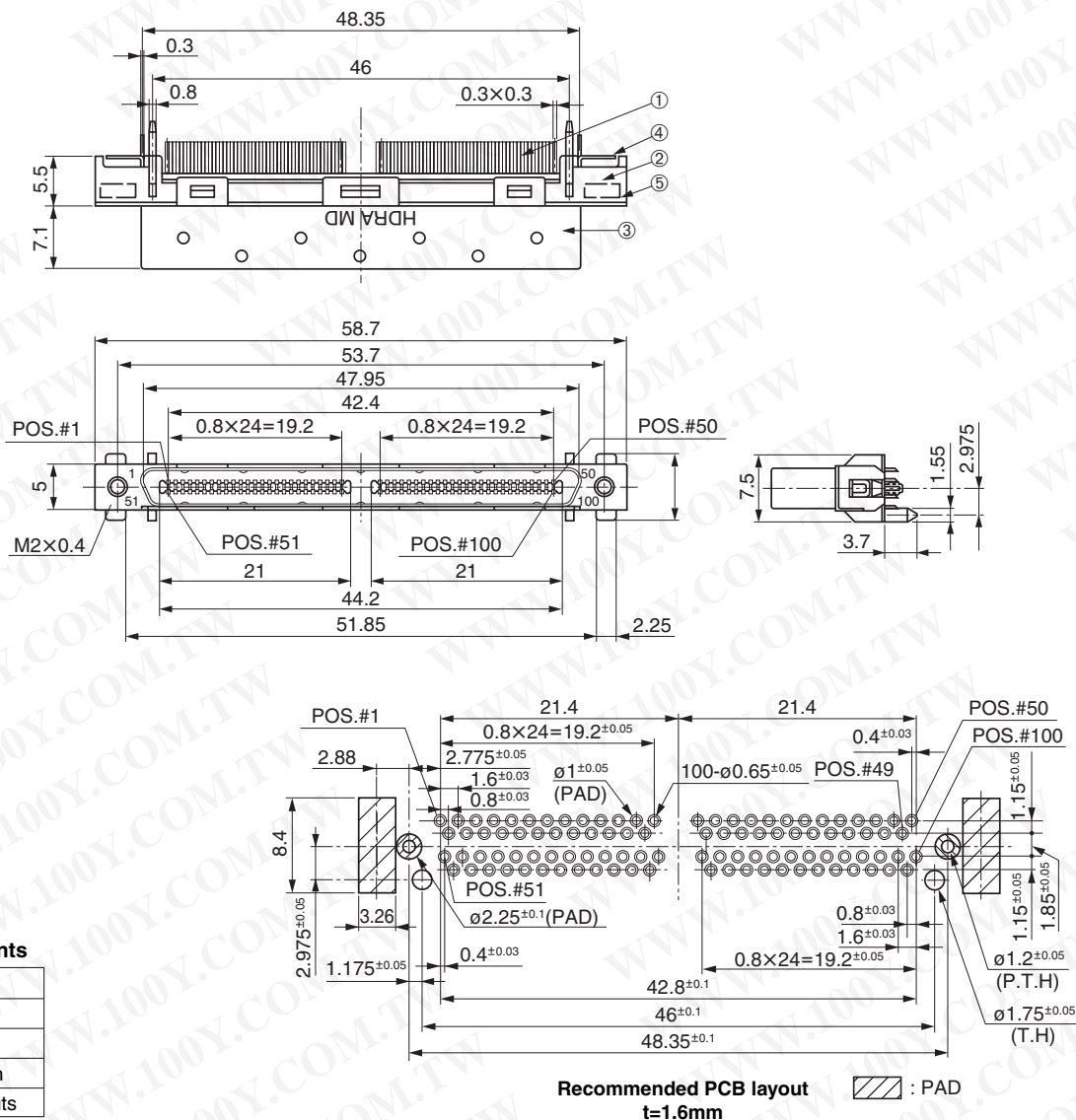

● Components

①	Contacts
②	Insulator
③	Shell
④	Hold down
⑤	Square nuts

Mating connector: HDR series female connector

**Straight through hole type female connector for PCB**  
**HDRA-EC68FDT+**

For PCB

Straight Through hole

RoHS

EMI shielded



● Configuration of product Part No.

**HDRA- EC 68 FD T+**

- ① Series name
- ② No. of contacts: 68
- ③ Type of contact  
FD: Straight through hole type, female
- ④ With hold downs

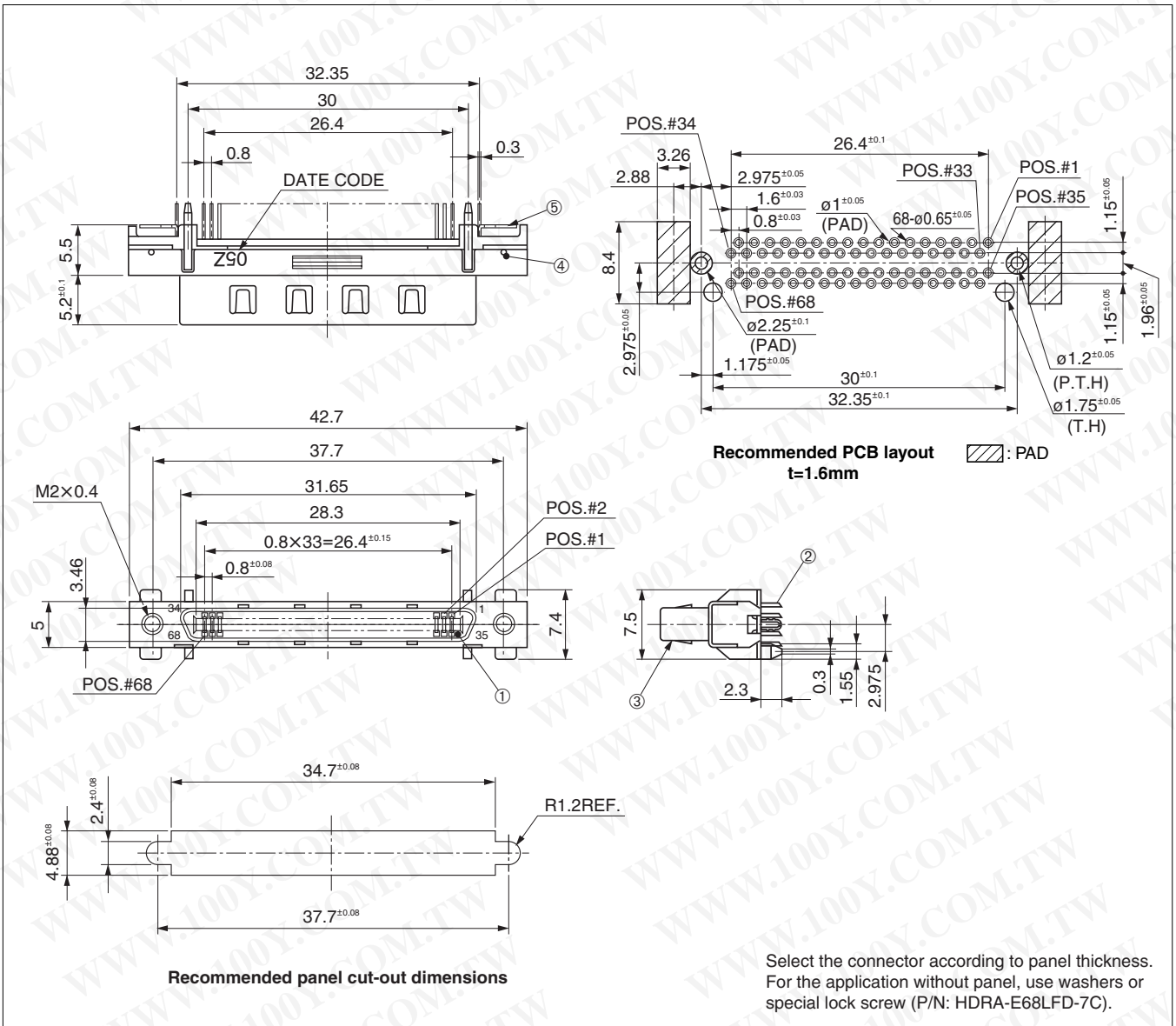

Mating connector: HDRA series male connector

# Straight through hole type female connector for PCB HDRA-EC100FDT+

For PCB

Straight Through hole

EMI shielded

RoHS



● Configuration of product Part No.

## HDRA- EC 100 FD T+

- ① Series name
- ② No. of contacts: 100
- ③ Type of contact  
FD: Straight through hole type, female
- ④ With hold downs

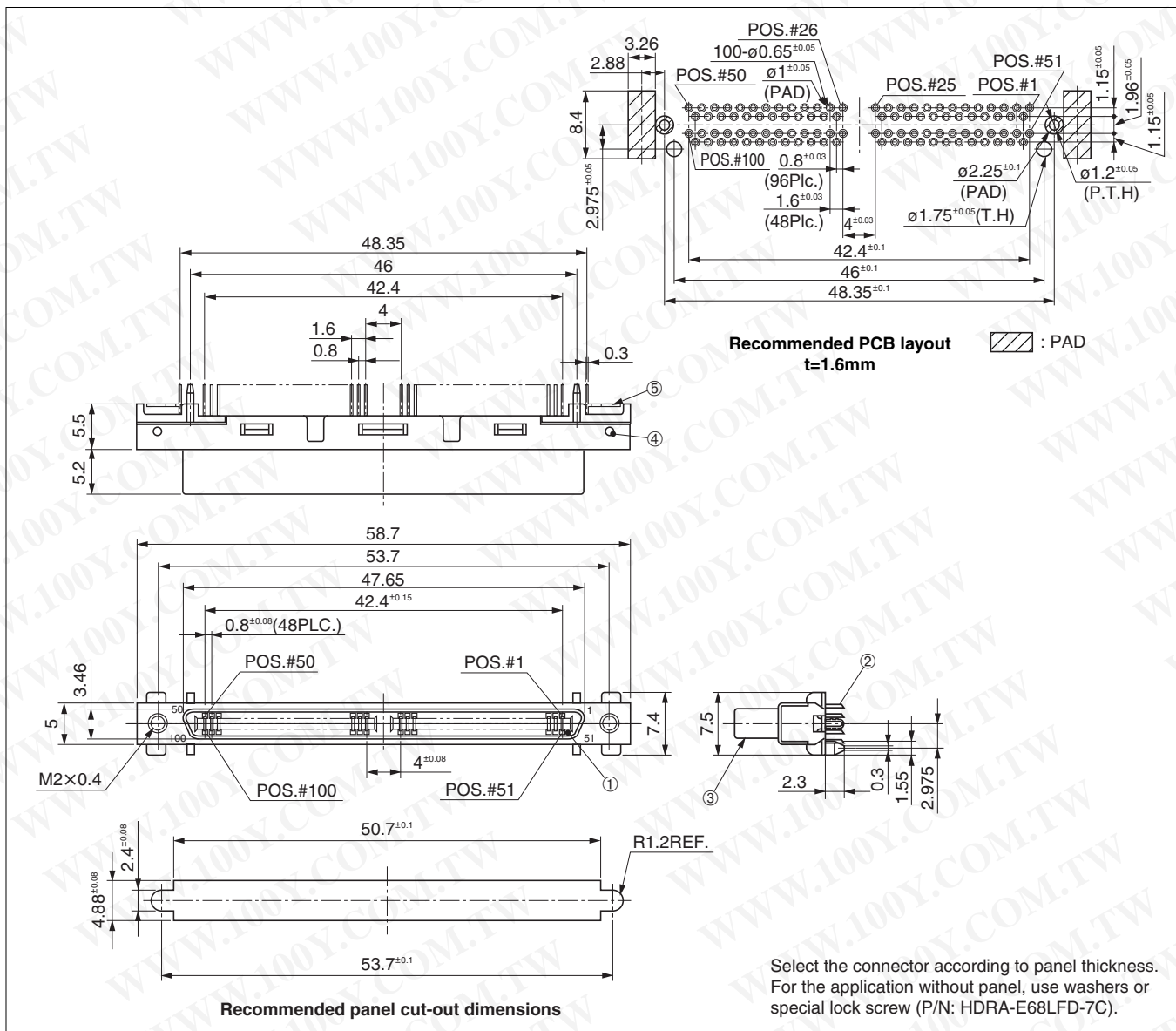

Mating connector: HDRA series male connector

Right-angle through hole type female connector for PCB  
**HDRA-E68LFD T-OM18+**

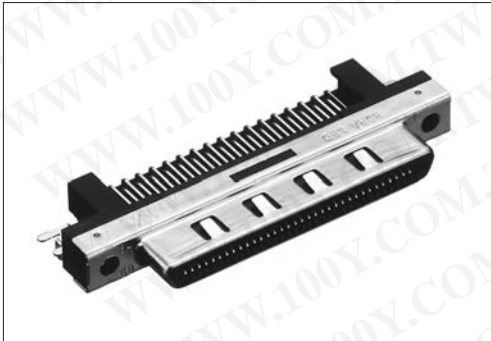

● Configuration of product Part No.

**HDRA- E 68 LFD T- OM18+**

- ① Series name
- ② No. of contacts: 68
- ③ Type of contact  
LFD: Right-angle through hole type, female
- ④ With hold downs
- ⑤ Distance between center of mating section and mounting surface (mm)

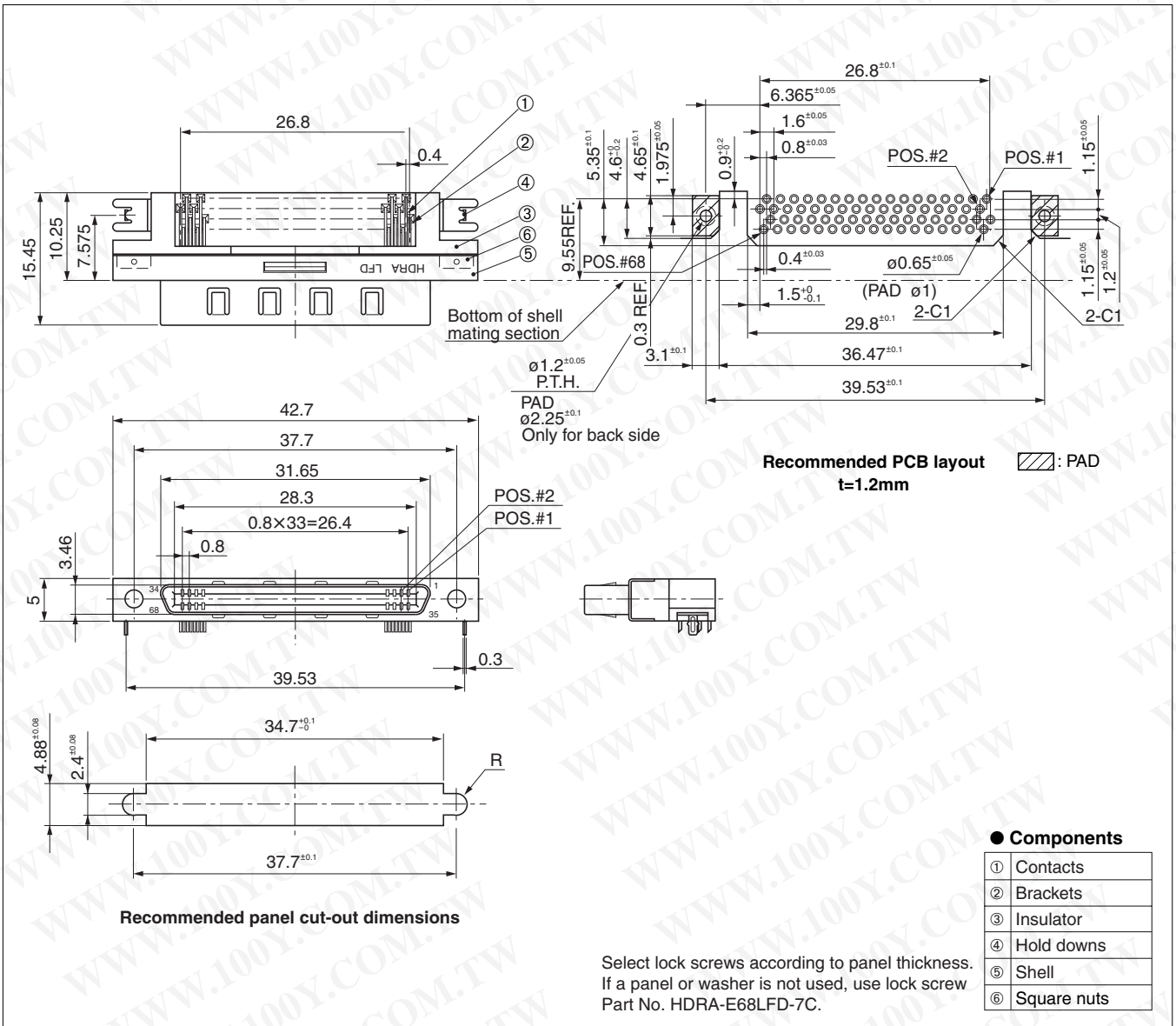

Mating connector: HDRA series IDC type male cable connector, or straddle SMT type male connector

# Right-angle through hole type female connector for PCB

## HDRA-E68LFD1T-( )+

RoHS

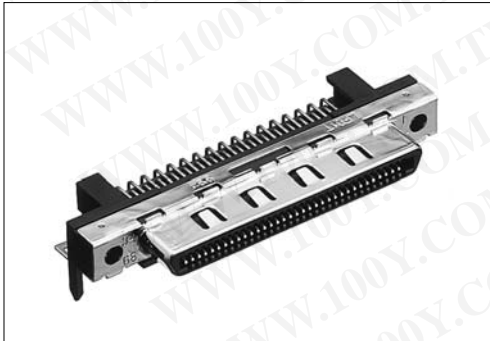

● Configuration of product Part No.

### HDRA-E 68 LFD 1 T -( )+

- |  |   |
|--|---|
| ① Series name  | ⑥ Lock screw                                  |
| ② No. of contacts: 68  | Blank: None                                   |
| ③ Type of contact:<br>LFD: Right-angle through hole type, female | SL : Provided<br>(Thickness of panel: 1.12mm) |
| ④ Provided with shell and panel contact blade                    |   |
| ⑤ Provided with board lock pin                                   |   |

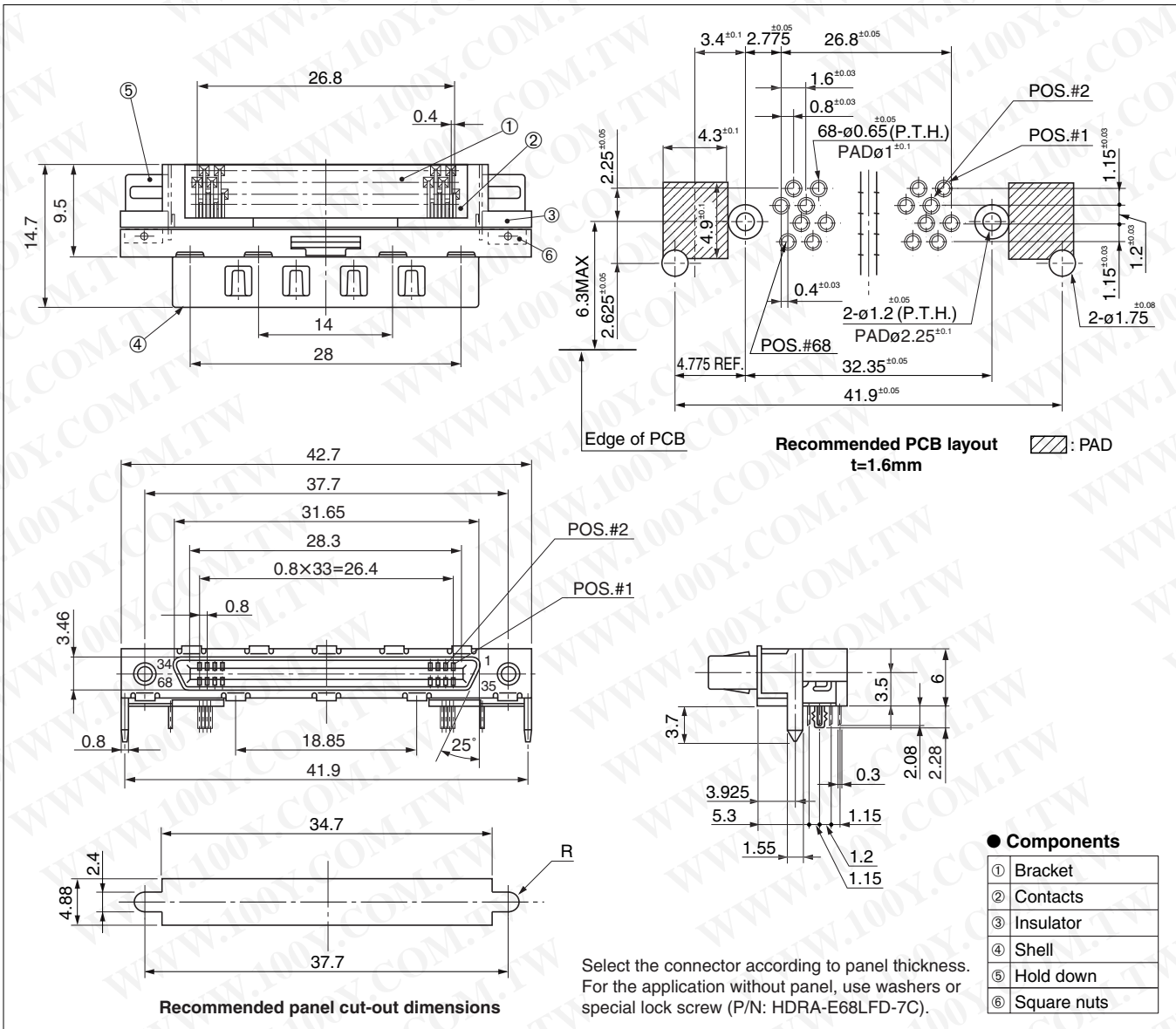

Mating connector: HDRA series IDC type male cable connector, or straddle SMT type male connector

Right-angle through hole type female connector for PCB  
 HDRA-EC68LFD T ( )-( )+

For PCB

Right-angle Through hole

RoHS

ANSI/SFF8441

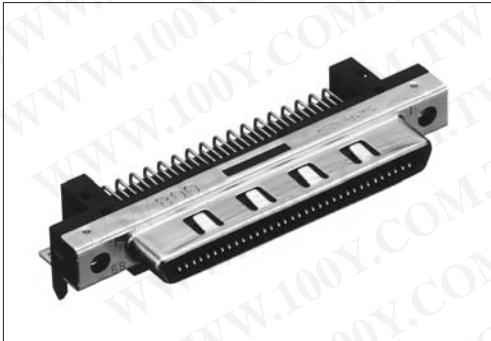

● Configuration of product Part No.

HDRA- EC 68 LFD T ( )-( )+

- |  |   |
|--|---|
| ① Series name  | S : A-2.08 mm contacts                      |
| ② No. of contacts: 68                                | B-2.28 mm board lock pins                   |
| ③ Type of contact                                    | C-2.3 mm location peg                       |
| LFD: Right-angle through hole type, female           | 2 : A-2.08 mm contacts                      |
| ④ With board lock pin                                | B-2.28 mm board lock pins                   |
| ⑤ Length of contact, board lock pins or location peg | C-1.4 mm location peg                       |
| Blank: A-2.08 mm contacts                            | ⑥ Lock screws                               |
| : B-2.28 mm board lock pins                          | Blank : None                                |
| : C-3.7 mm location peg                              | SL : provided (Thickness of panel: 1.12 mm) |

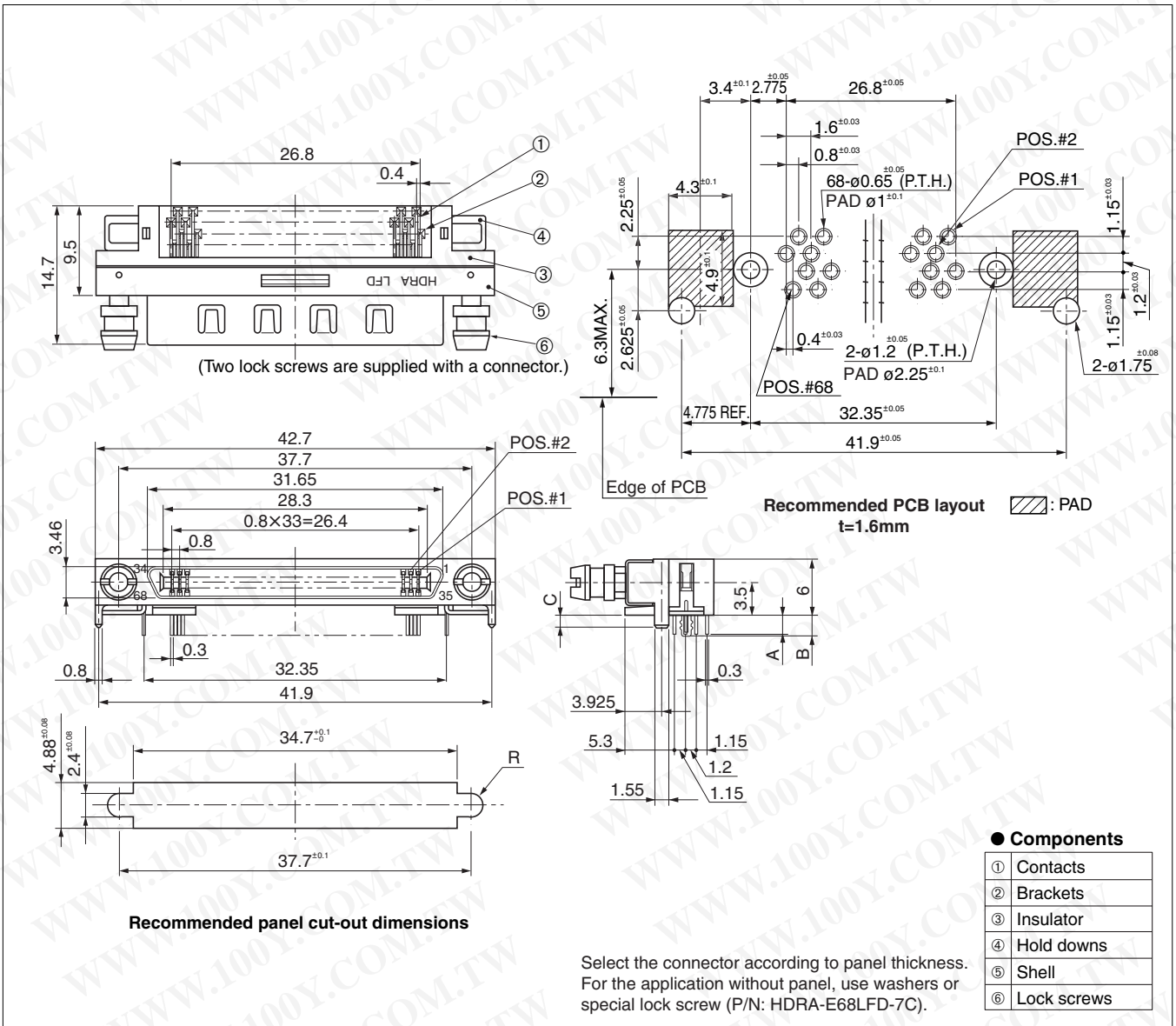

Mating connector: HDRA series IDC type male cable connector, or straddle SMT type male connector

# Right-angle through hole type female connector for PCB HDRA-EC100LFD T ( )-( )+

RoHS



● Configuration of product Part No.

## HDRA- EC 100 LFD T ( )-( )+

- |  |                            |
|--|----------------------------|
| ① Series name                              | ⑥ Lock screw               |
| ② No. of contacts: 100                     | Blank: None                |
| ③ Type of contact                          | SL : Provided              |
| LFD: Right-angle through hole type, female | (Panel thickness: 1.12 mm) |
| ④ With ground contact                      | GP : Guide pin             |
| ⑤ Through hole length                      |                            |
| Blank: 2.08 mm                             |                            |
| 1 : 3.4 mm (under planning)                |                            |

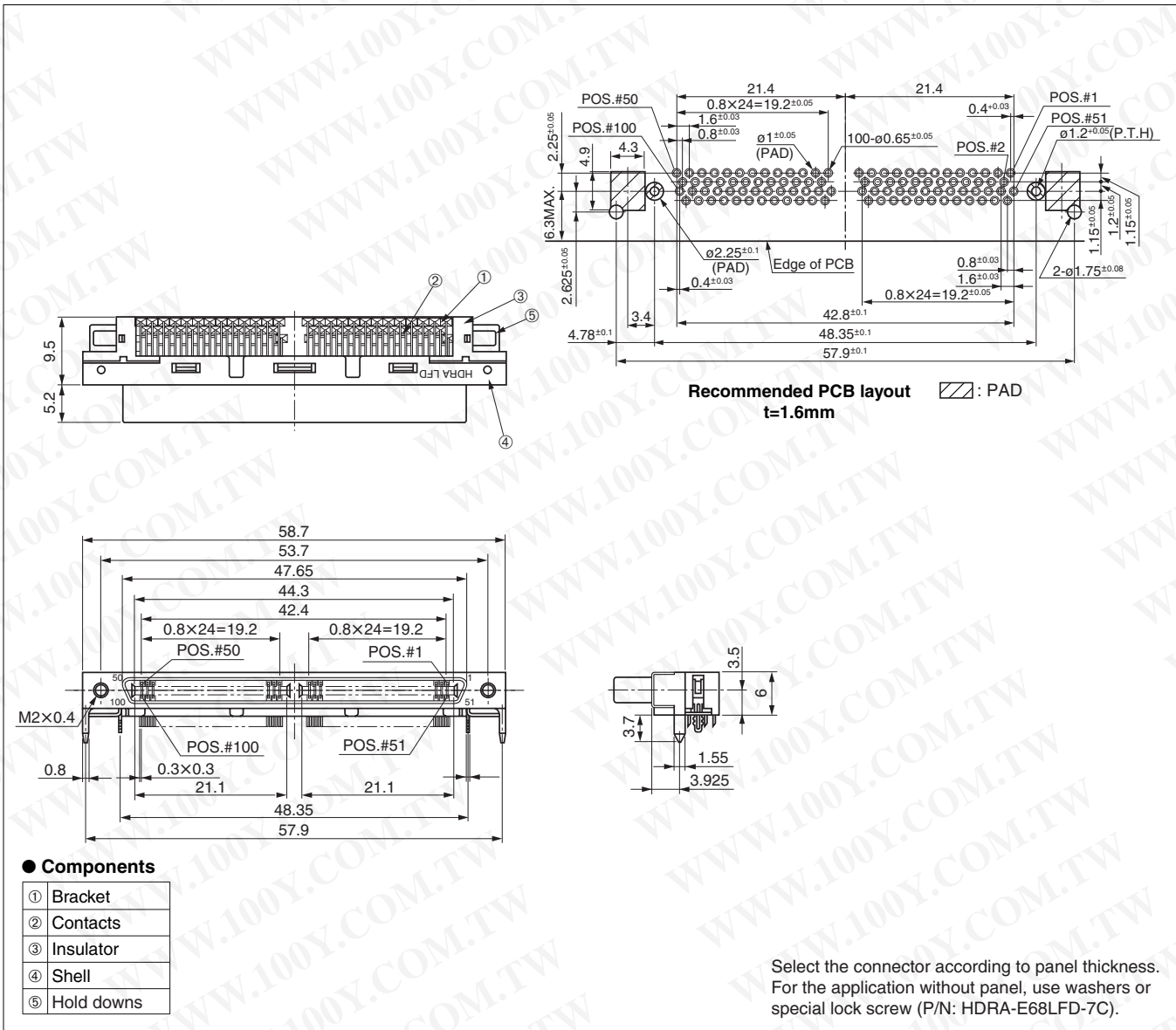

Mating connector: HDRA series male connector

Right-angle through hole type female connector for PCB  
 HDRA-EA36LFD T-( )+

For PCB

Right-angle Through hole

RoHS

ANSI/SFF8441



● Configuration of product Part No.

**HDRA- EA 36 LFD T-( )+**

- ① Series name
- ② No. of contacts: 36
- ③ Type of contact  
LFD: Right-angle through hole type, female
- ④ Provided with board lock mechanism
- ⑤ Lock screw  
Blank: None  
SL : Provided (Thickness of panel: 1.12 mm)

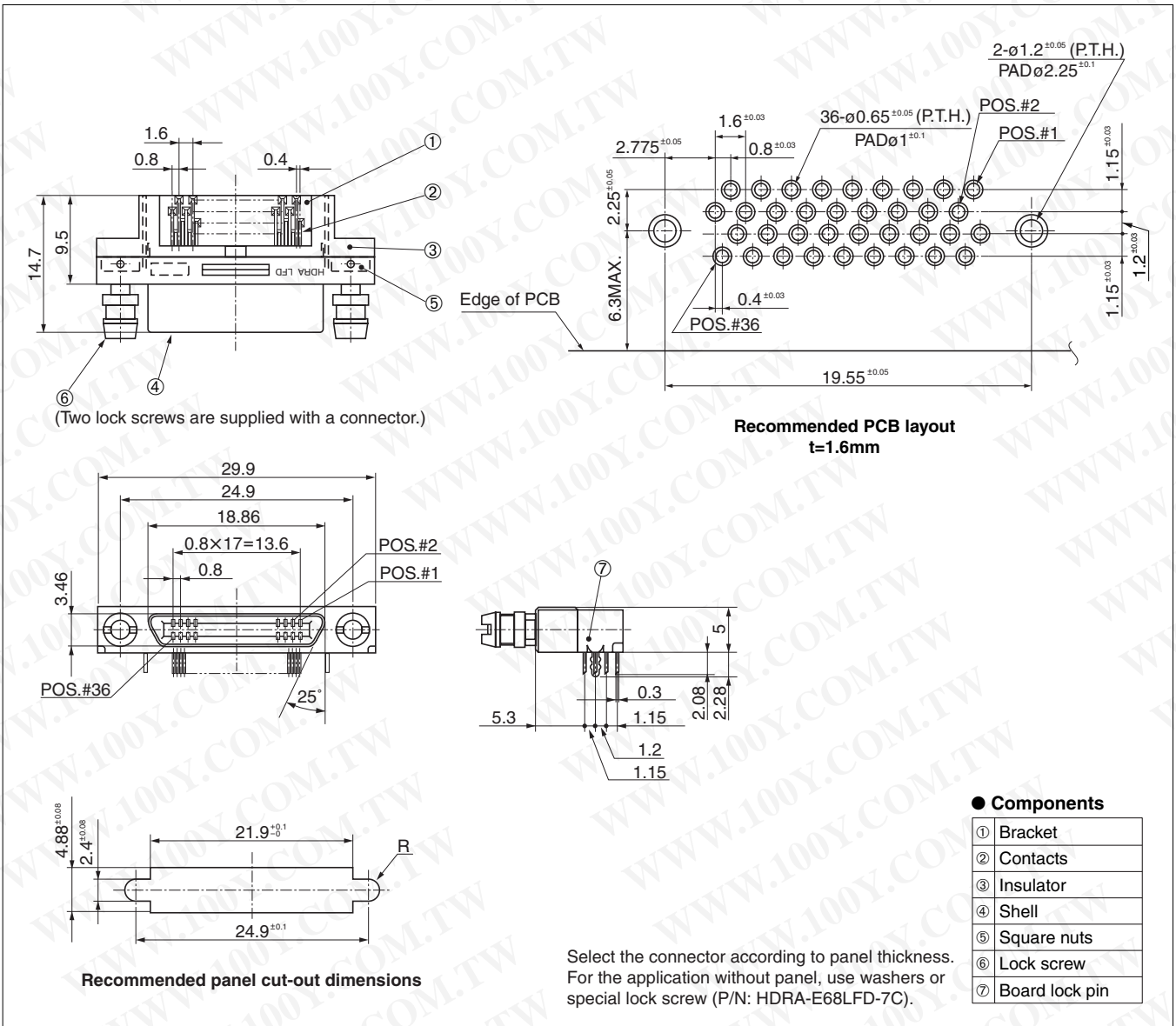

● Components

①	Bracket
②	Contacts
③	Insulator
④	Shell
⑤	Square nuts
⑥	Lock screw
⑦	Board lock pin

Select the connector according to panel thickness.  
 For the application without panel, use washers or special lock screw (P/N: HDRA-E68LFD-7C).

Mating connector: HDRA series IDC type male cable connector

Note● Jack screw is not available at present.

# Right-angle through hole type female connector for PCB HDRA-E100LFD T ( )-( )+

RoHS



● Configuration of product Part No.

## HDRA- E 100 LFD T ( )-( )+

- |                           |   |
|---------------------------|---|
| ① Series name             | ⑤ Length of contacts and board lock pins    |
| ② No. of contacts: 100    | Blank: A-2.08 mm contacts                   |
| ③ Type of contact         | B-2.28 mm board lock pins                   |
| LFD: Right-angle          | 1 : A-3.4 mm contacts                       |
| through hole type, female | B-2.6 mm board lock pins                    |
| ④ With board lock pin     | ⑥ Lock screws                               |
|                           | Blank: None                                 |
|                           | SL : provided (Thickness of panel: 1.12 mm) |

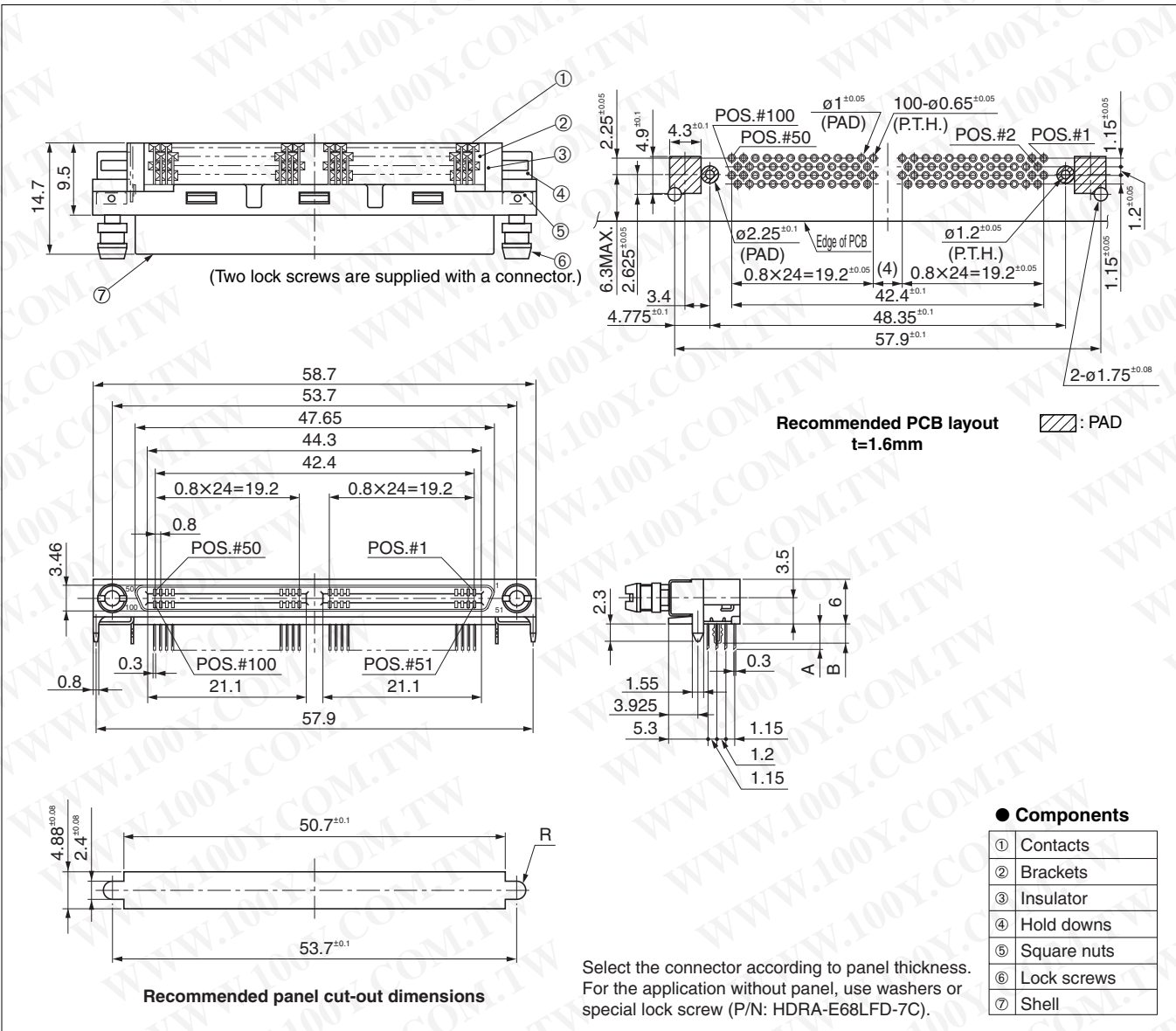

● Components

①	Contacts
②	Brackets
③	Insulator
④	Hold downs
⑤	Square nuts
⑥	Lock screws
⑦	Shell

Mating connector: HDRA series IDC type male connector

Right-angle through hole type female connector for PCB  
 HDRA-E68W1LFDT-( )+

For PCB

Right-angle Through hole

RoHS

ANSI/SFF8441

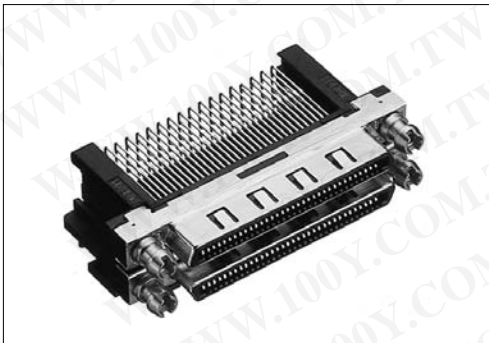

● Configuration of product Part No.

**HDRA- E 68 W 1 LFD T- ( )+**

- ① Series name
- ② No. of contacts: 136 (68×2)
- ③ No. of stacks: 2
- ④ Type of contact  
LFD: Right-angle through hole type, female
- ⑤ With location peg
- ⑥ Lock screw  
Blank: None  
SL : Provided (Thickness of panel: 1.12 mm)

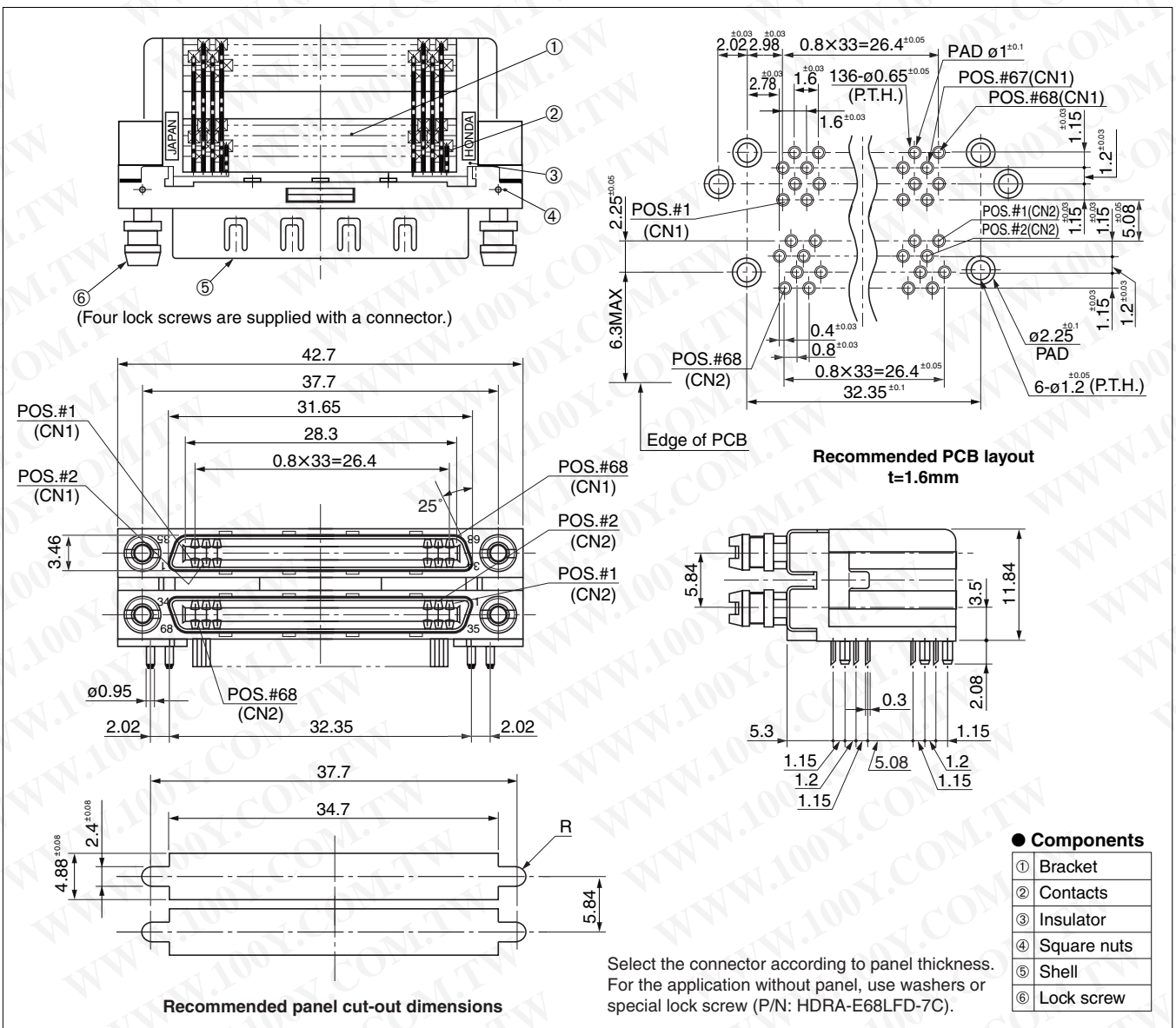

Mating connector: HDRA series IDC type male cable connector, or straddle SMT type male connector

# Right-angle through hole type female connector for PCB HDRA-E68W( )LFD T1 E C(-)+



● Configuration of product Part No.

## HDRA- E 68 W ( ) LFD T1 E C (-)+

- |  |  |
|--|--|
| ① Series name  | ⑥ Earth lock pin (provided with board lock mechanism)                      |
| ② No. of contacts: 136 (68×2)  | ⑦ Provided with shell connection reinforcement                             |
| ③ No. of stacks: 2   | ⑧ Provided with protection cover for contacts and bends                    |
| ④ Length of contact, through hole<br>1: 2.08 (PCB: 1.6 mm thick)<br>2: 3.4 (PCB: 2.4 mm thick) | ⑨ Lock screw<br>Blank: None<br>SL : Provided (Thickness of panel: 1.12 mm) |
| ⑤ Type of contact<br>LFD: Right-angle through hole type, female                                |  |

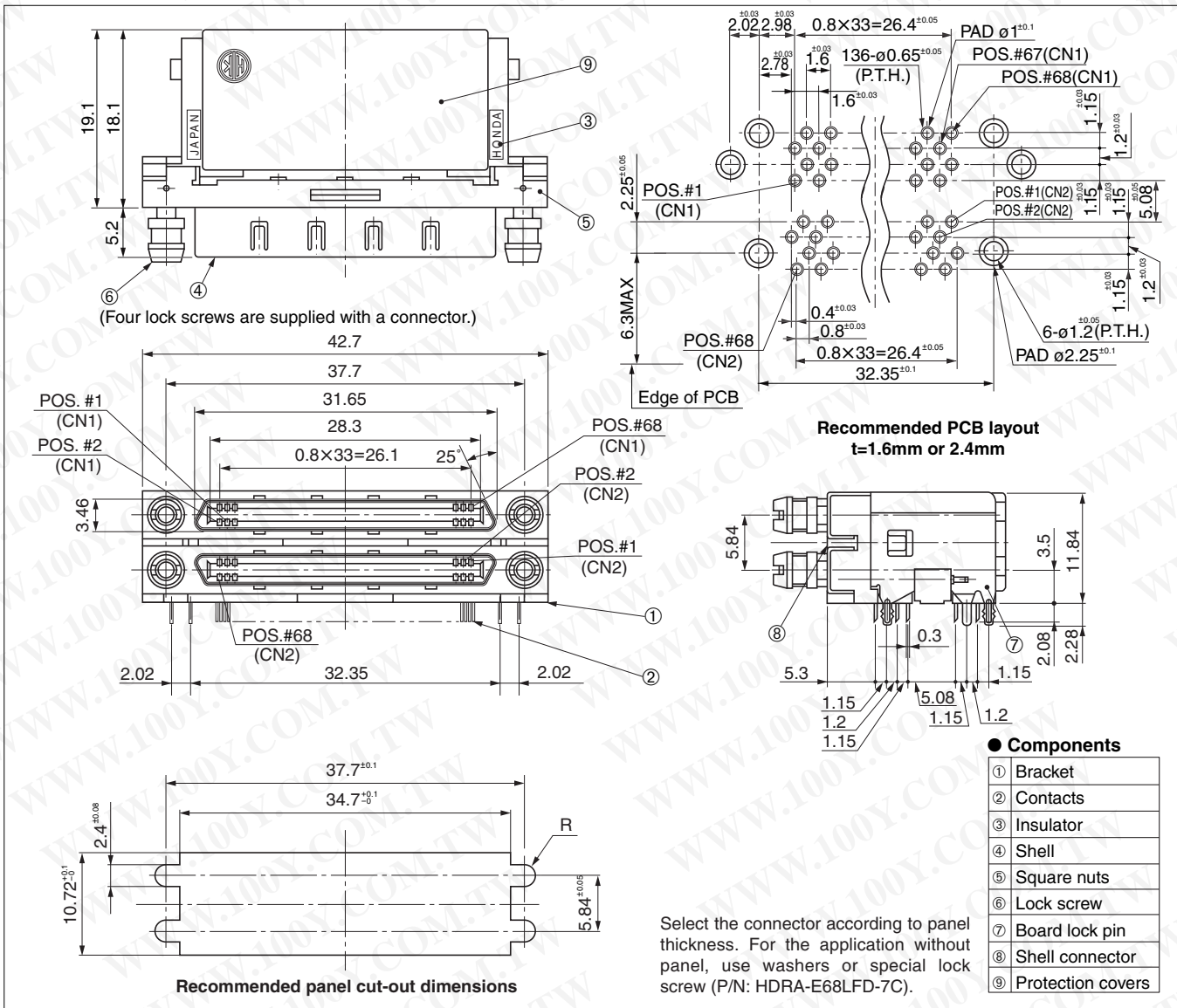

● Components

①	Bracket
②	Contacts
③	Insulator
④	Shell
⑤	Square nuts
⑥	Lock screw
⑦	Board lock pin
⑧	Shell connector
⑨	Protection covers

Mating connector: HDRA series IDC type male cable connector, or straddle SMT type male connector

Right-angle through hole type female connector for PCB  
 HDRA-E100W( )LFDT1EC-( )+

For PCB

Right-angle Through hole

RoHS

ANSI/SFF8441



● Configuration of product Part No.

**HDRA- E 100 W ( ) LFD T1 E C- ( )+**

- ① Series name
- ② No. of contacts: 100
- ③ W: Double stacked connector
- ④ Length of contacts or board lock pins
  - 1: A-2.08 mm contacts
  - B-2.28 board lock pins
  - 2: A-3.4 mm contacts
  - B-3.6 mm board lock pins
- ⑤ Type of contact
  - LFD: Right-angle through hole type, female
  - SL : provided (Thickness of panel: 1.12 mm)
- ⑥ Earth lock pin (provided with board lock mechanism)
- ⑦ Provided with shell connection reinforcement
- ⑧ Provided with protection cover for contacts and bends
- ⑨ Lock screws
- Blank: None

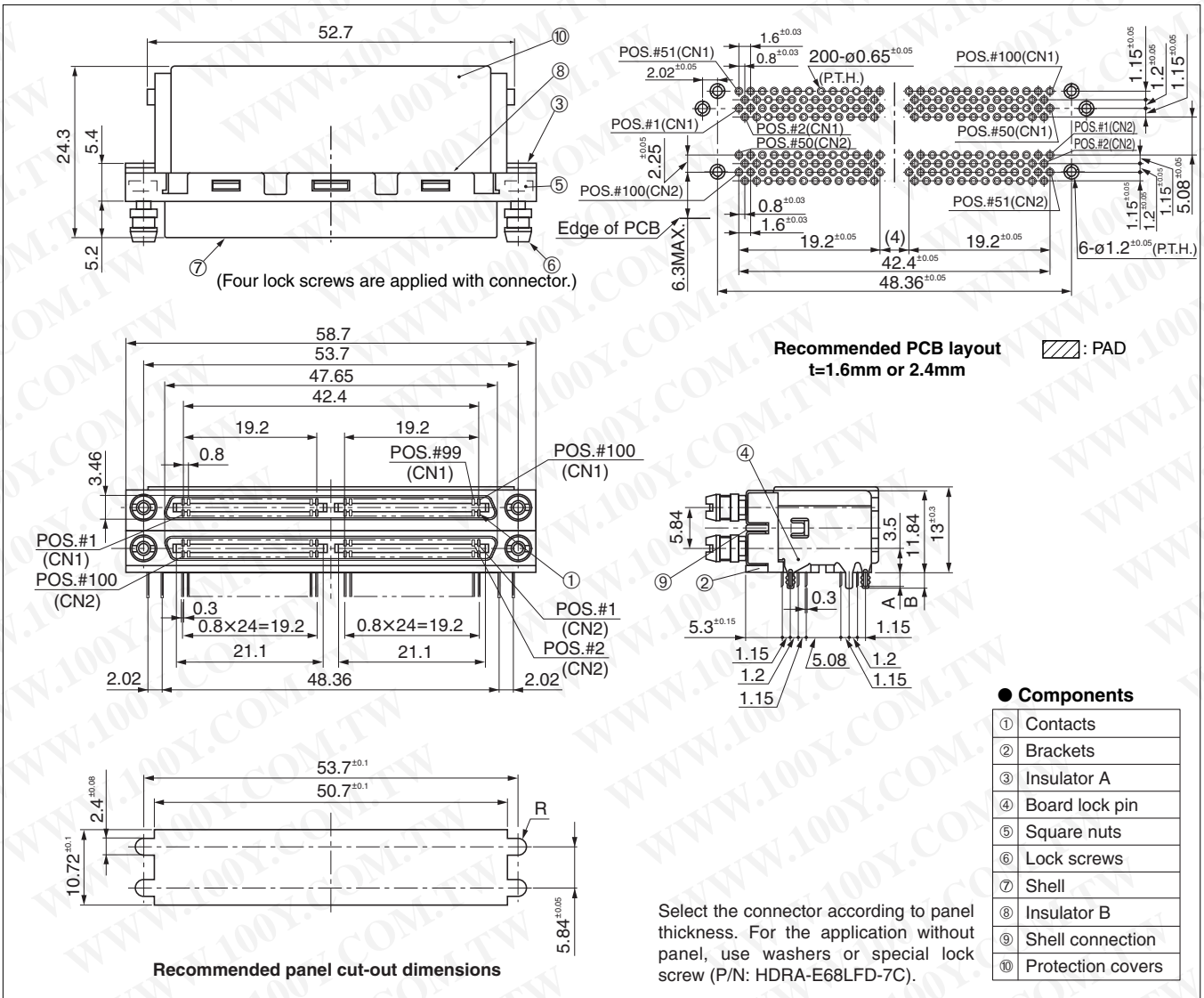

● Components

①	Contacts
②	Brackets
③	Insulator A
④	Board lock pin
⑤	Square nuts
⑥	Lock screws
⑦	Shell
⑧	Insulator B
⑨	Shell connection
⑩	Protection covers

Mating connector: HDRA series IDC type male connector

# Straight SMT type female connector for PCB

## HDRA-E68FYT-( )+

For PCB

Straight SMT

ANSI/SFF8441

RoHS



● Configuration of product Part No.

### HDRA-E 68 FY T-( )+

- ① Series name
- ② No. of contacts: 68
- ③ Type of contact  
FY: Straight SMT type, female
- ④ Provided with board lock mechanism
- ⑤ Lock screw  
Blank: None  
SL : Provided  
(Thickness of panel: 1.12 mm)

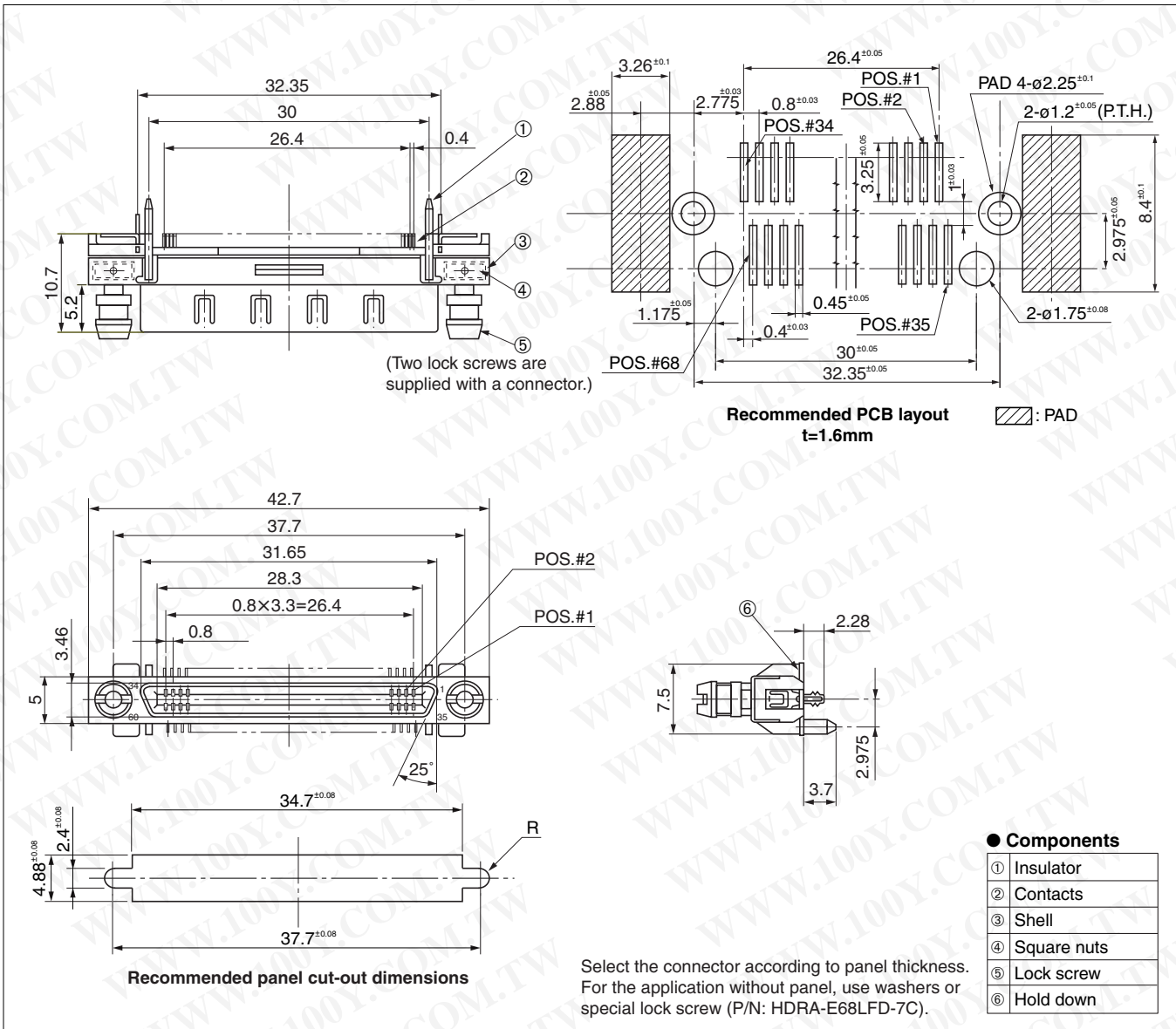

Mating connector: HDRA series IDC type male cable connector, or straddle SMT type male connector

Right-angle SMT type female connector for PCB  
 HDRA-ED68LFZGT( )-( )+

For PCB

Right-angle SMT

ANSI/SFF8441

RoHS



● Configuration of product Part No.

**HDRA- ED 68 LFZ G T ( ) - ( ) +**

- |                                    |                               |
|------------------------------------|-------------------------------|
| ① Series name                      | ⑥ Form of shell               |
| ② No. of contacts: 68              | Blank : Standard shell        |
| ③ Type of contact                  | A : Shell with flange for EMI |
| LFZ: Right-angle, female           | ⑦ Lock screws                 |
| ④ Contact plating                  | L: Provided                   |
| G: 0.76 μm Gold plate              |                               |
| ⑤ Ground lock pins with hold downs |                               |

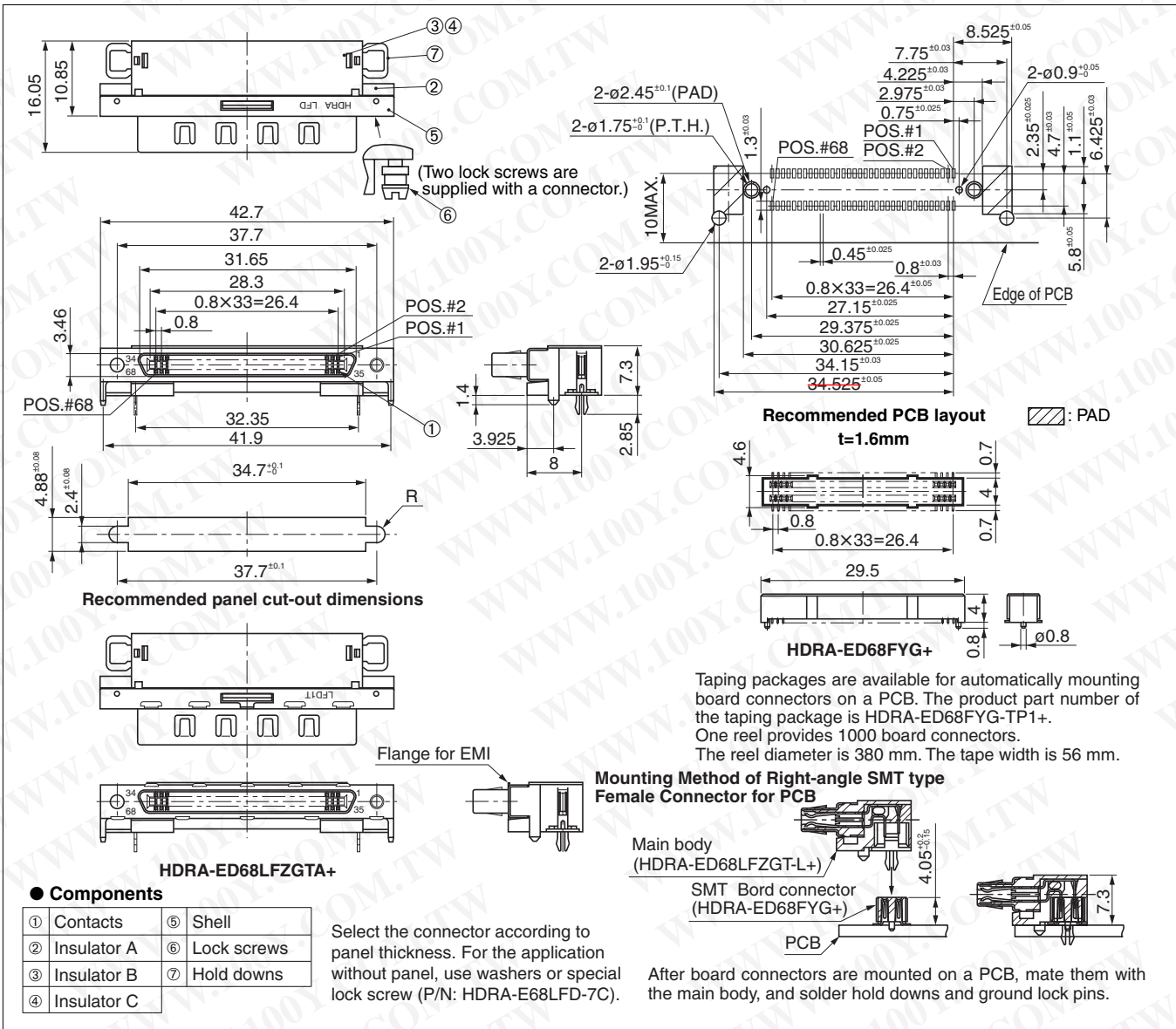

Mating connector: HDRA series IDC type male cable connector, or straddle SMT type male connector

Right-angle SMT type female connector for PCB  
 HDRA-ED136LFZGT( )-( )+

For PCB

Right-angle SMT

ANSI/SFF8441

RoHS



● Configuration of product Part No.

HDRA- ED 136 LFZ G T ( )-( )+

- ① Series name
- ② No. of contacts: 136
- ③ Type of contact  
LFZ: Right-angle SMT type, female
- ④ Contact plating  
G: 0.76 μm Gold plate
- ⑤ Ground lock pins with hold downs
- ⑥ Form of shell  
Blank: Standard shell  
A: Shell with flange for EMI
- ⑦ Lock screws  
L: Provided  
(Panel thickness: t = 1.12 mm or less)

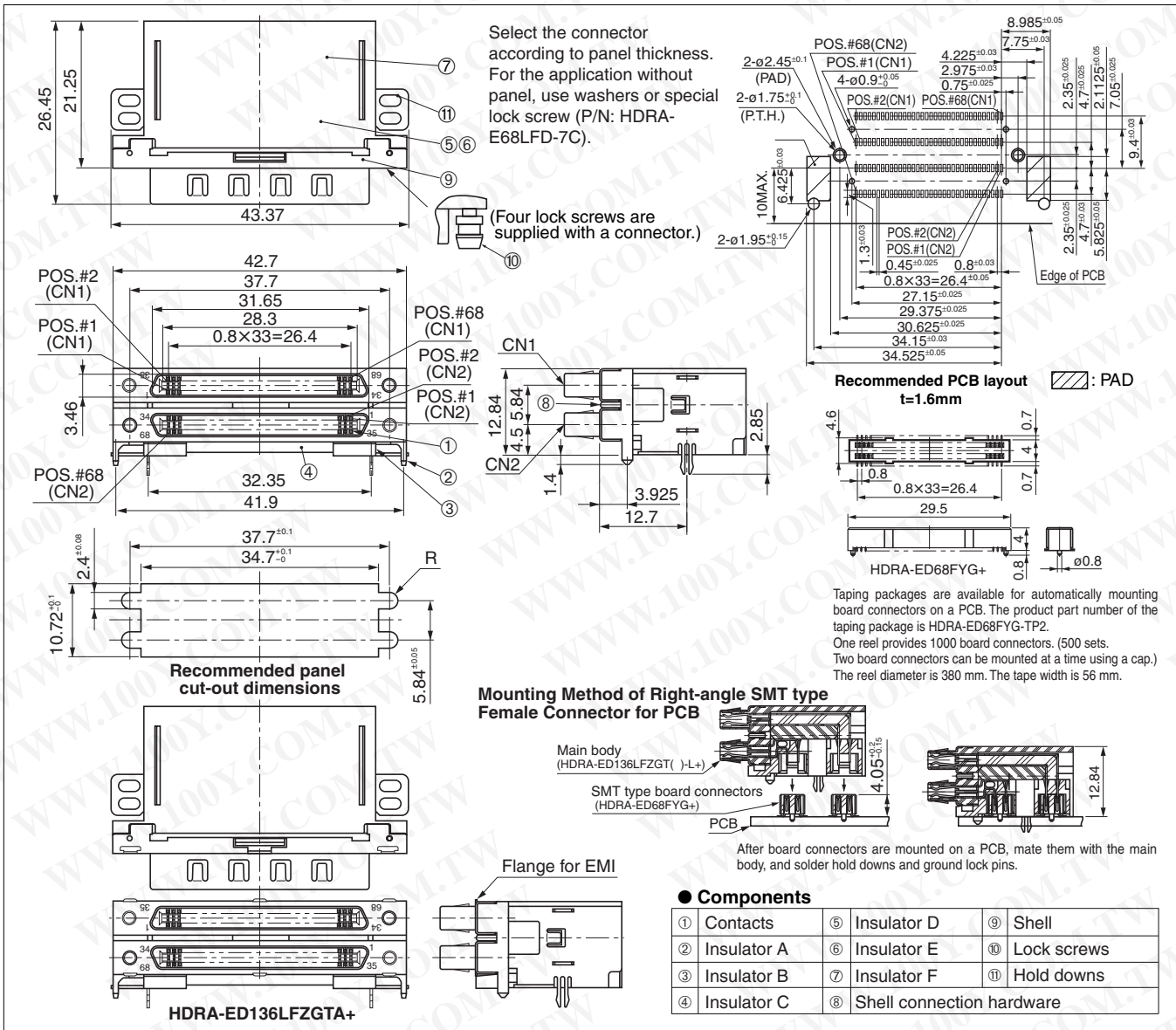

Mating connector: HDRA series IDC type male cable connector, or straddle SMT type male connector

# Straddle SMT type female connector for PCB HDRA-E68FT+

For PCB

Straddle SMT

ANSI/SFF8441

RoHS

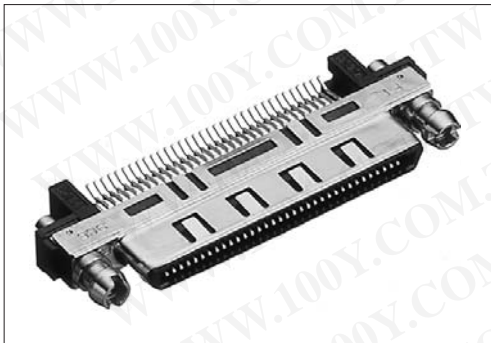

● Configuration of product Part No.

## HDRA- E 68 FT+

- ① Series name
- ② No. of contacts: 68
- ③ Type of contact  
FT: Straddle SMT type, female

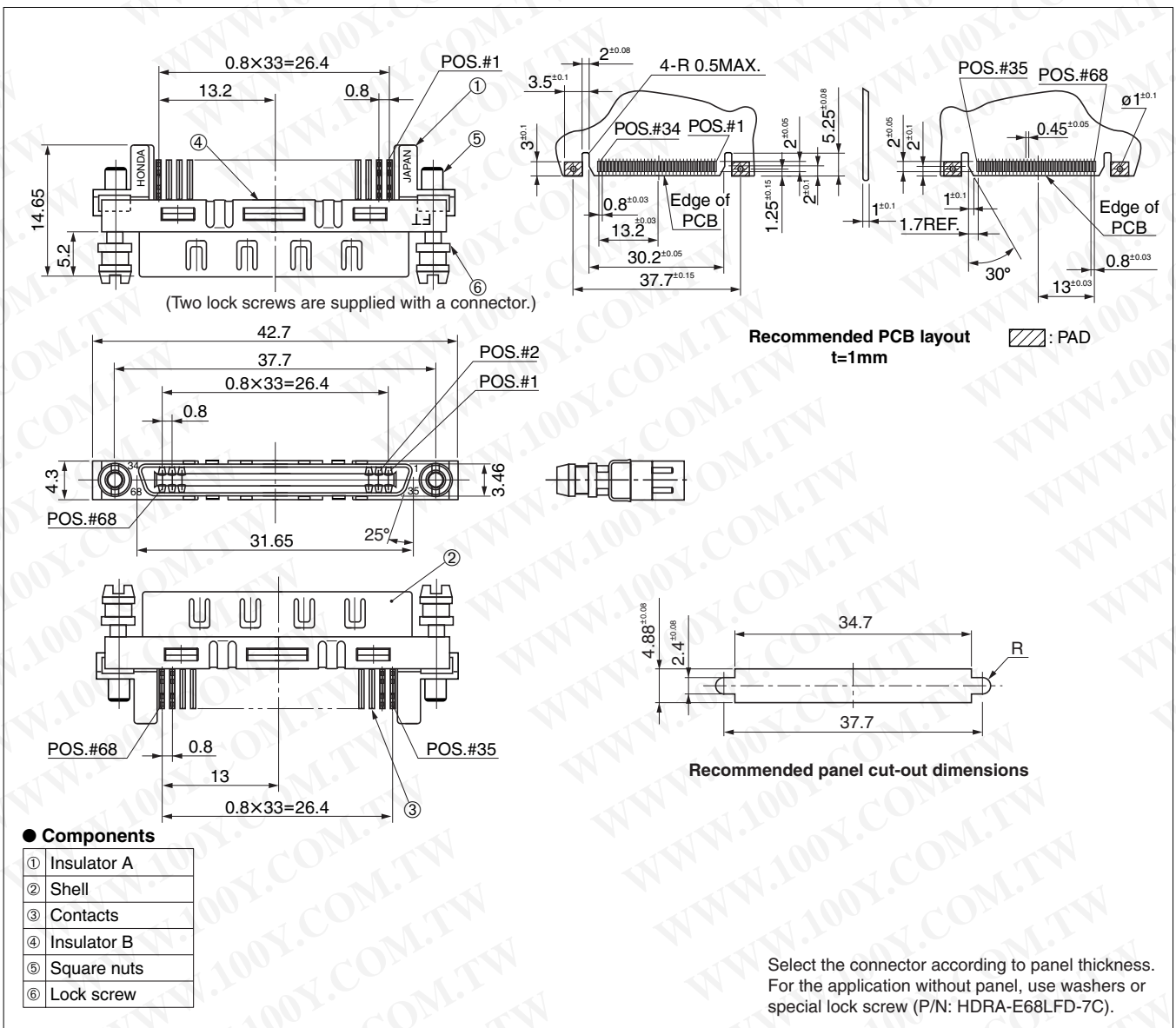

Mating connector: HDRA series IDC type male cable connector, or straddle SMT type male connector

Straddle SMT type female connector for PCB  
 HDRA-E68FT2-( )+

For PCB

Straddle SMT

ANSI/SFF8441

RoHS

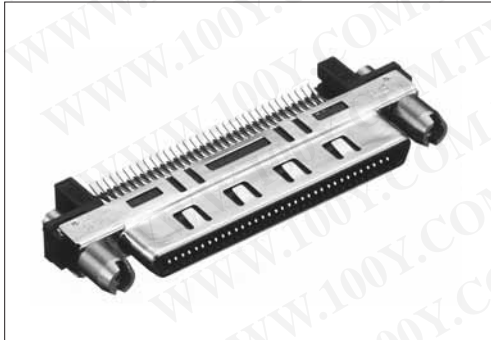

● Configuration of product Part No.

**HDRA- E 68 FT 2- ( )+**

- ① Series name
- ② No. of contacts: 68
- ③ Type of contact  
 FT: Straddle SMT type, female
- ④ PCB thickness: 0.5 mm
- ⑤ Lock screws  
 Blank: None  
 SL : provided

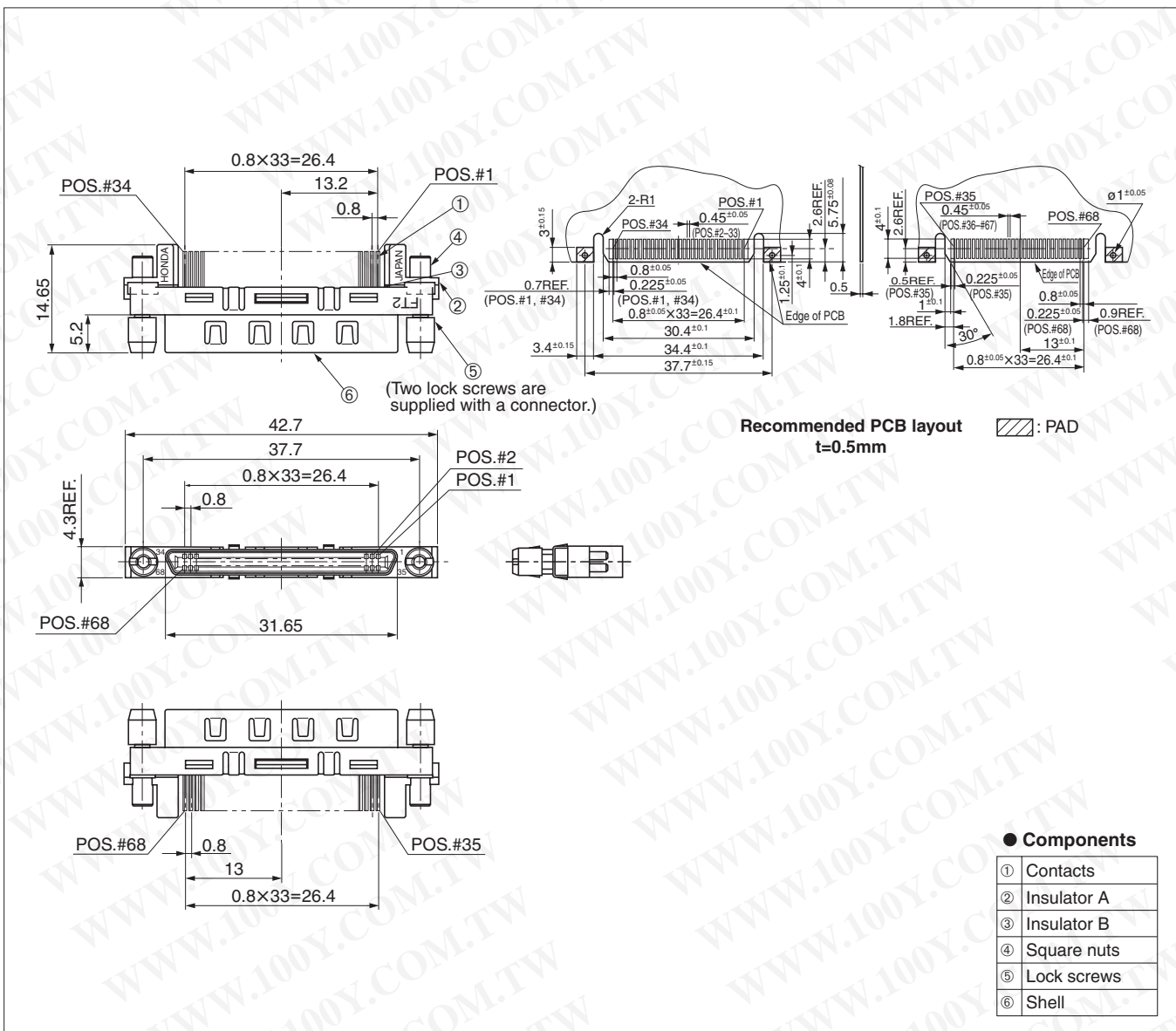

Mating connector: HDRA series IDC type male cable connector, or straddle SMT type male connector



# EMI-shielded vertical plastic housing for standard cable HDRA-E68LGKP( )

Vertical housing

EMI shielded

ANSI/SFF8441

RoHS



● Configuration of product Part No.

## HDRA- E 68 LGKP ( )

- ① Series name
- ② No. of contacts: 68
- ③ A: Vertical cable holding type  
C: Vertical ultrasonic welding type  
E: Vertical ultrasonic welding type  
F: Vertical ultrasonic welding type  
Outside diameter of cable is shown in the dimension table.

### HDRA-E68LGKPA

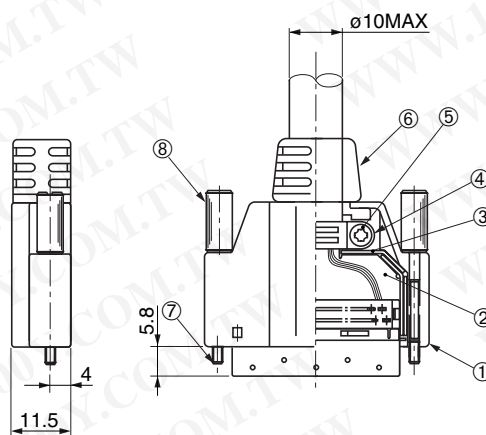
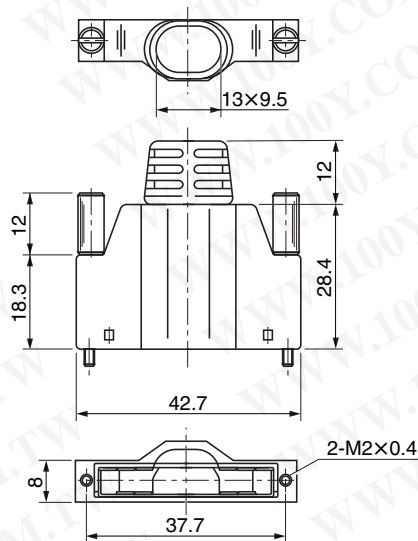

Thumb screw with plastic cap should be tightened by hand. For screw driver assembly use the product (P/N: HDRA-E68LGKPE3) with metal thumb screws attached.

● Components

①	Cover
②	Inner shell A
③	Inner shell B
④	Cable clamp
⑤	Screw
⑥	Bushing
⑦	Thumb screw
⑧	Cap (plastic)

### HDRA-E68LGKPC, LGKPE, LGKPF

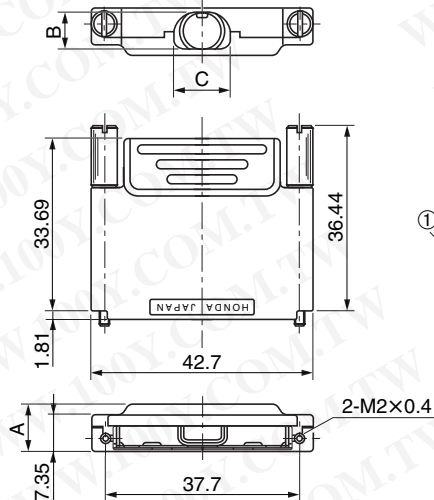

The following figure shows HDRA-E68LGKPF.

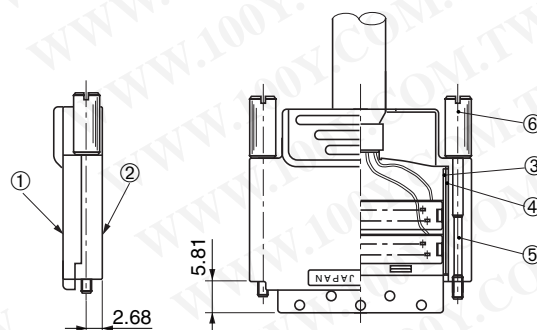

● Components

①	Cover A
②	Cover B
③	Shell A
④	Shell B
⑤	Thumb screw
⑥	Cap (plastic)

Part No.	A	B	C
HDRA-E68LGKPC	11.5	9.5	10.5x9.5
HDRA-E68LGKPE	9.5	7.5	
HDRA-E68LGKPF	9	7.2	10.5

For use with connectors : HDR series IDC type cable connector : -LGKPA for MA, -LGKPC/-LGKPE for MA1, and -LGKPF for MC1

Required tools (for LGKPC, LGKPE and LGKPF): Clamp caulking tools: FLPT-0017B (Refer to page Tool-10)

Ultrasonic welder, Housing holding jig, Sonic welder

**EMI-filtered vertical metallic housing  
HDRA-E100LPA**

Housing

Vertical

EMI filtered

RoHS



● Configuration of product Part No.

**HDRA- E 100 LP A**

①                      ②                      ③                      ④

- ① Series name
- ② No. of contacts: 100
- ③ Type of housing: Vertical type
- ④ Compatible cable  
A: Outside diameter of cable is 9.8 mm

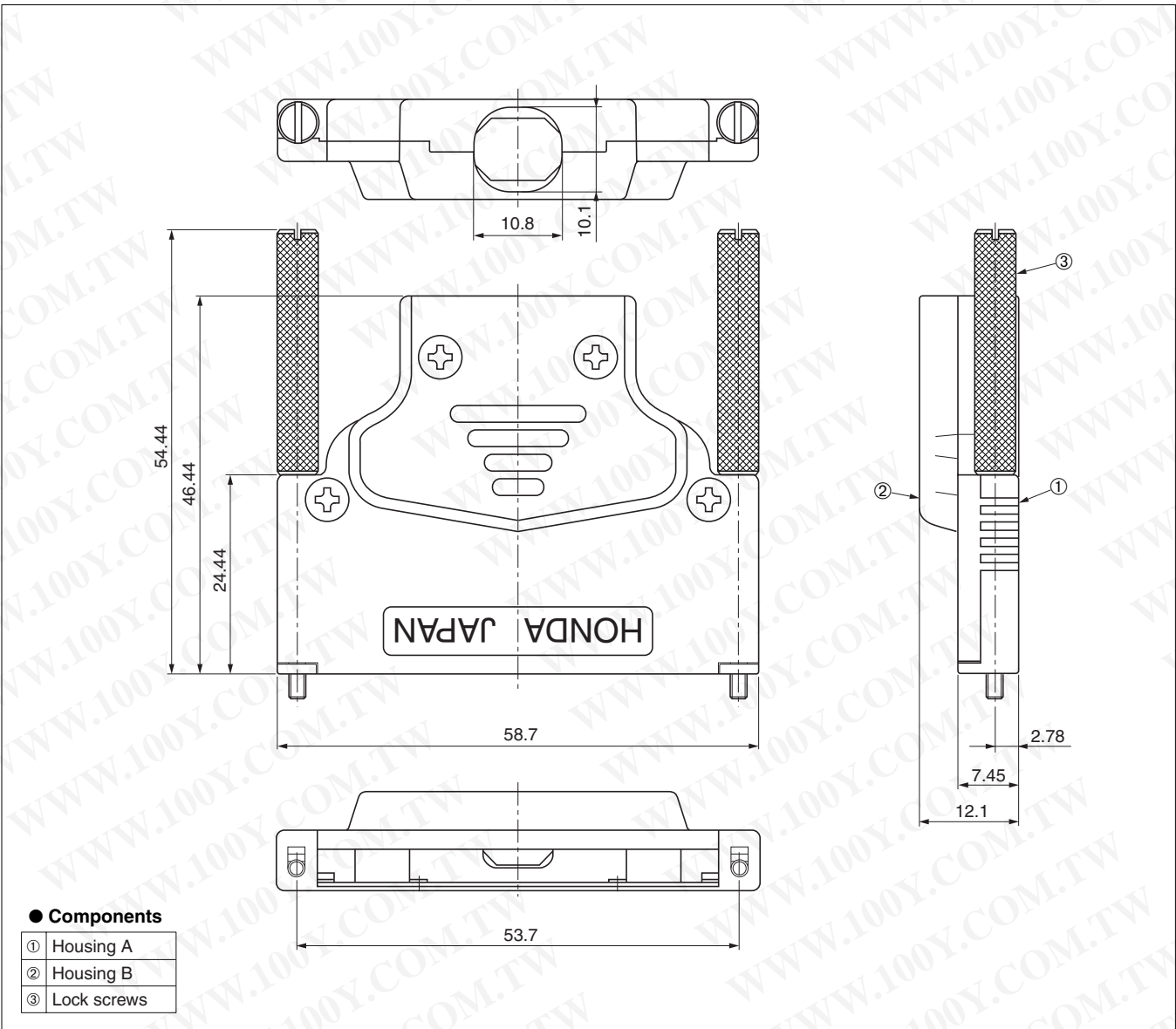

● Components

①	Housing A
②	Housing B
③	Lock screws

For use with connectors: HDRA-E100M( )1+

EMI-filtered vertical metallic housing  
HDRA-E100LPW( )

Housing

Vertical

RoHS

EMI filtered



● Configuration of product Part No.

**HDRA- E 100 LP W ( )**

- ① Series name
- ② No. of contacts: 100
- ③ Type of housing: Vertical type
- ④ Compatible cable and form of through hole  
 B : Two holes are available for two cables. Outside diameters of cable are 6.9 mm  
 C : One hole is available for one cable. Outside diameter of cable is 9.6 mm

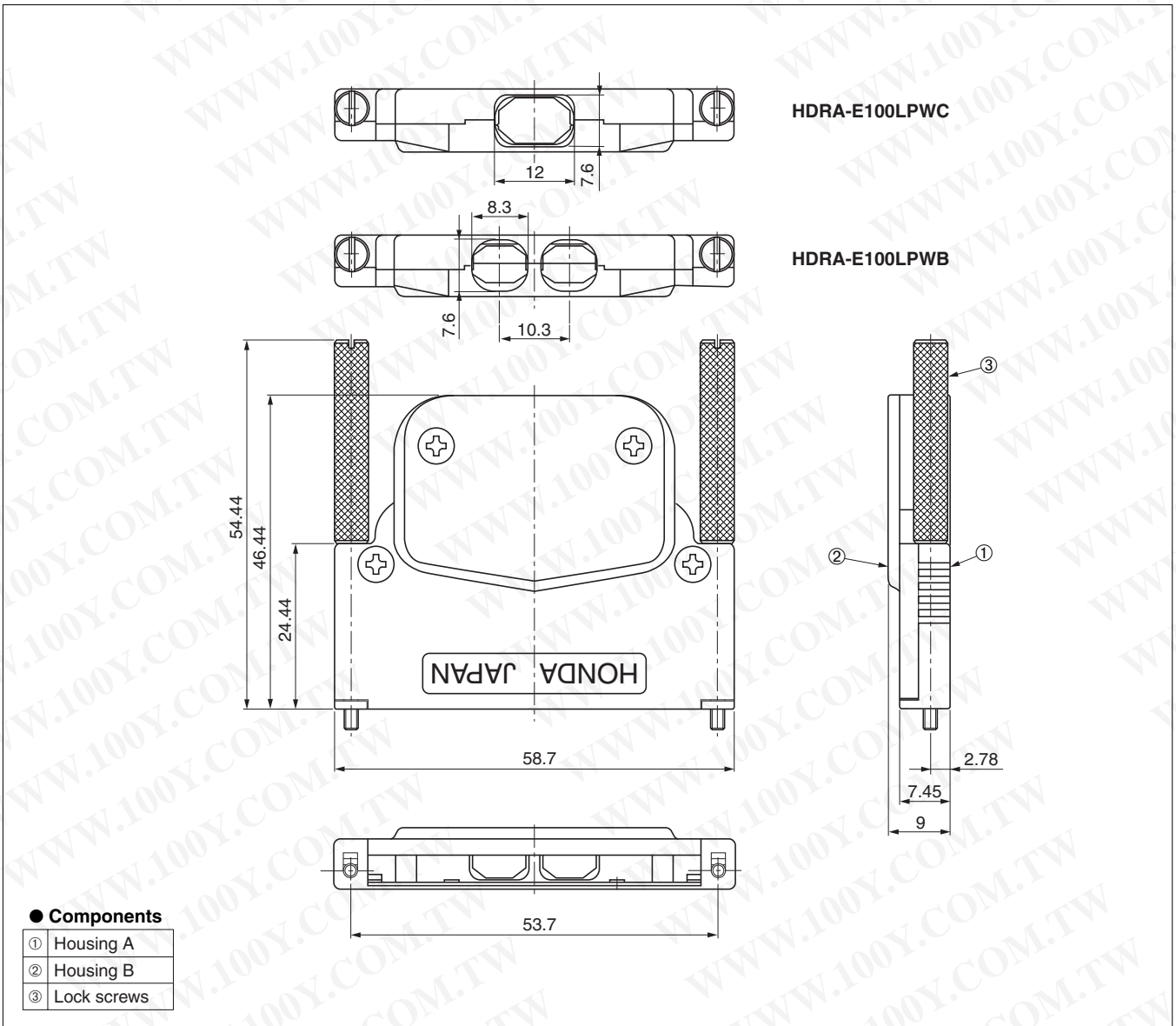

For use with connectors: HDRA-E100M( )1+

EMI-shielded vertical plastic housing  
HDRA-E36LPTH

Vertical housing

EMI shielded

RoHS

ANSI/SFF8441



● Configuration of product Part No.

**HDRA- E 36 LPTH**

① ② ③

- ① Series name
- ② No. of contacts: 36
- ③ Type of housing: Vertical type

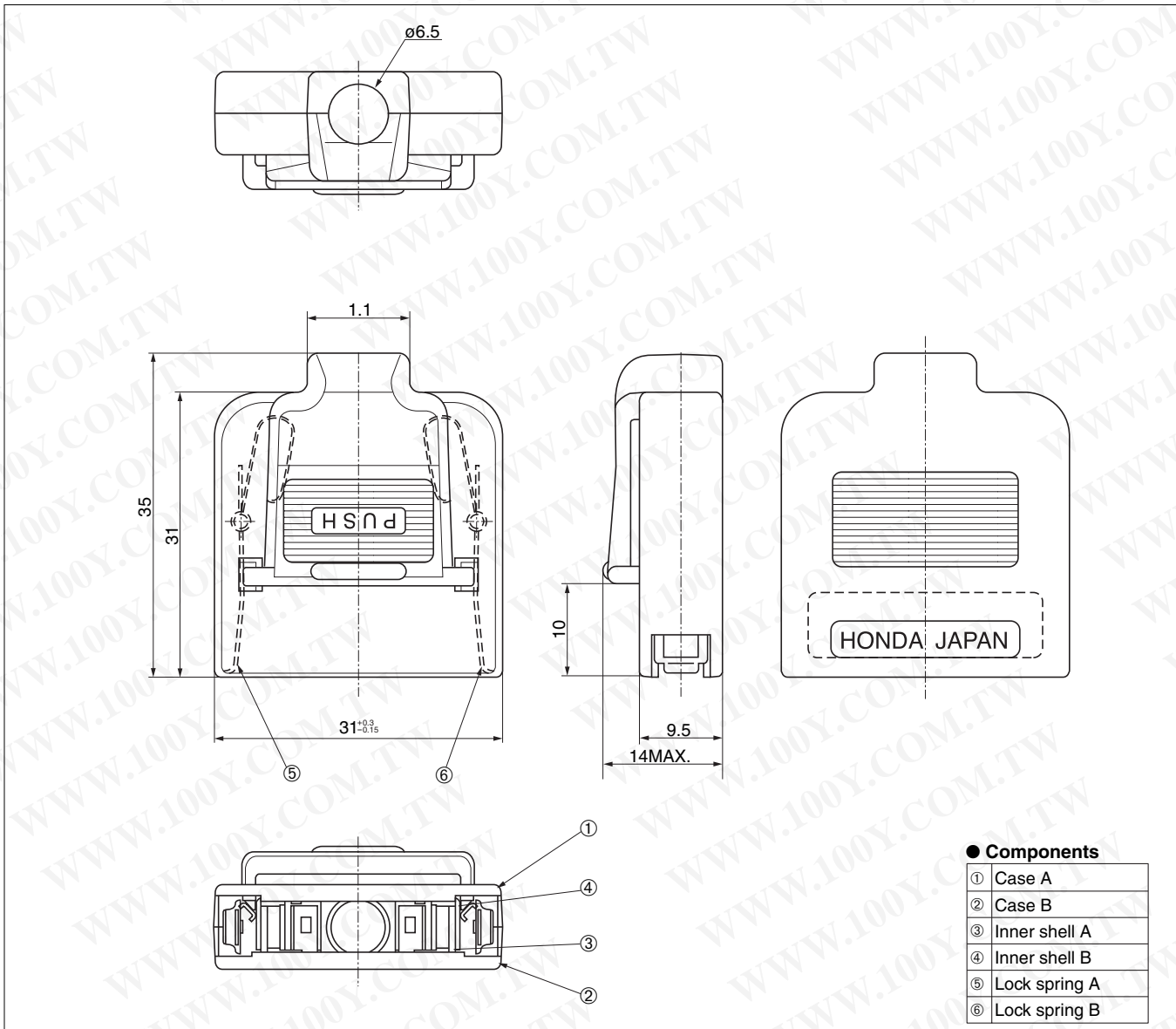

● Components

①	Case A
②	Case B
③	Inner shell A
④	Inner shell B
⑤	Lock spring A
⑥	Lock spring B

For use with connectors: HDRA-E36M(+)

Mating connectors: HDRA -EA36LFDT+ + Lock screw (HDR-E14LMY-SL-02C) panel:0.5-0.8mm thick  
-EA36FT-NS+ + Lock screw (HDR-E14LMY-SL-02C) panel:0.5-0.8mm thick

Required tools: Clamp caulking tools: FLPT-0024A (Refer to page Tool-10) Ultrasonic welder, Housing holding jig, Sonic welder

Dust-proof cap  
HDRA-E68( )-CP

Accessories

Cap

RoHS

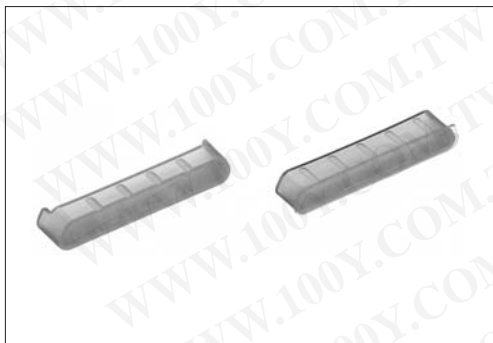

● Configuration of product Part No.

**HDRA- E 68 ( )- CP**

- ① Series name
- ② No. of contacts: 68
- ③ M : For male connector  
F : For female connector
- ④ Cap

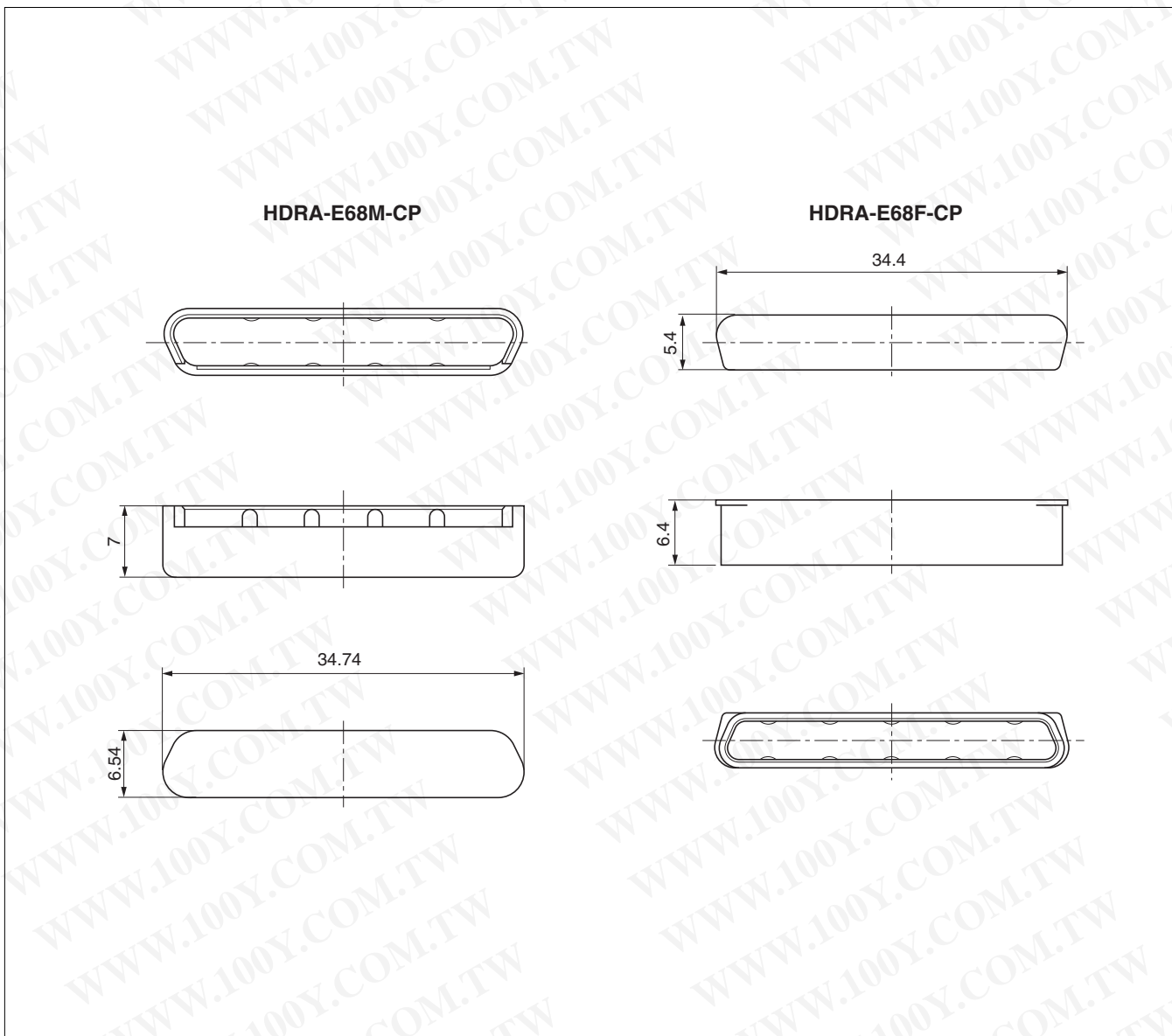

For use with housings: HDRA-E68LGKPC-F

-----

-----

-----

**Straight DIP type female connector for PCBs**  
**HDRA-EC68FDT-( )+**

**0.8 mm pitch connector**

**For PCBs**

**Straight DIP**

**EMI-filtered countermeasures**

RoHS

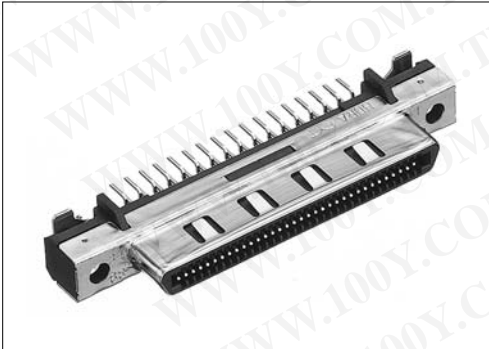

● Configuration of product Part No.

**HDRA- EC 68 FD T- ( )+**

①                      ②                      ③                      ④                      ⑤

- ① Series name
- ② No. of contacts: 68
- ③ Form of contact  
FD: Straight, DIP type, female
- ④ With ground lock pin
- ⑤ Lock screw  
SLD: Provided  
Blank: None

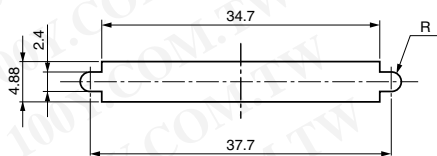
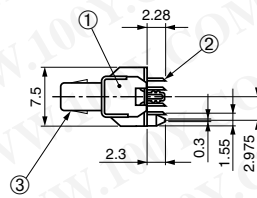
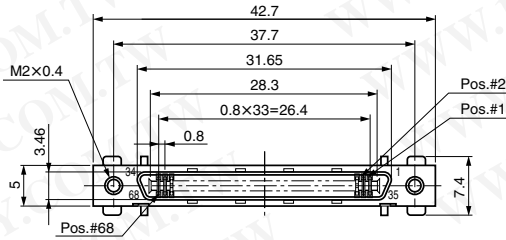
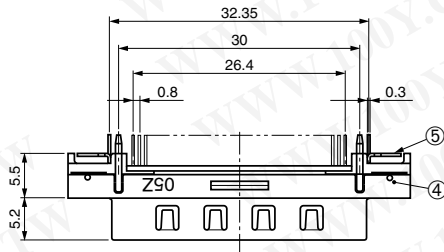

Recommended panel cut-out dimensions

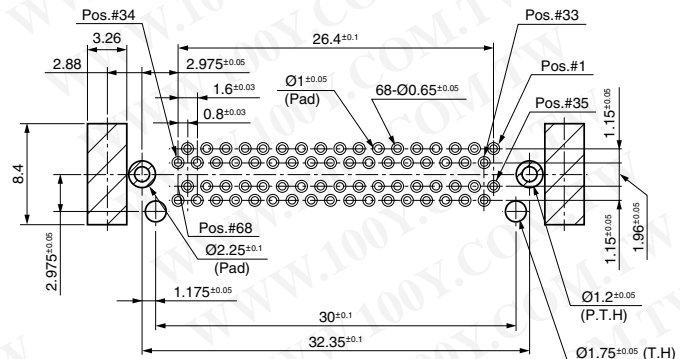

Recommended PCB layout

● Components

①	Insulator
②	Contact
③	Shell
④	Sqr.nut
⑤	Hold down

Mating connector: HDRA series male connectors

**Straight DIP type female connector for PCBs**  
**HDRA-EC100FDT-( )+**

**0.8 mm pitch connector**

**For PCBs**

**Straight DIP**

**RoHS**

**EMI-filtered countermeasures**



● Configuration of product Part No.

**HDRA- EC 100 FD T- ( )+**

①                      ②                      ③                      ④                      ⑤

- ① Series name
- ② No. of contacts: 100
- ③ Form of contact  
FD: Straight, DIP type, female
- ④ With ground lock pin
- ⑤ Lock screw  
SLD: Provided  
Blank: None

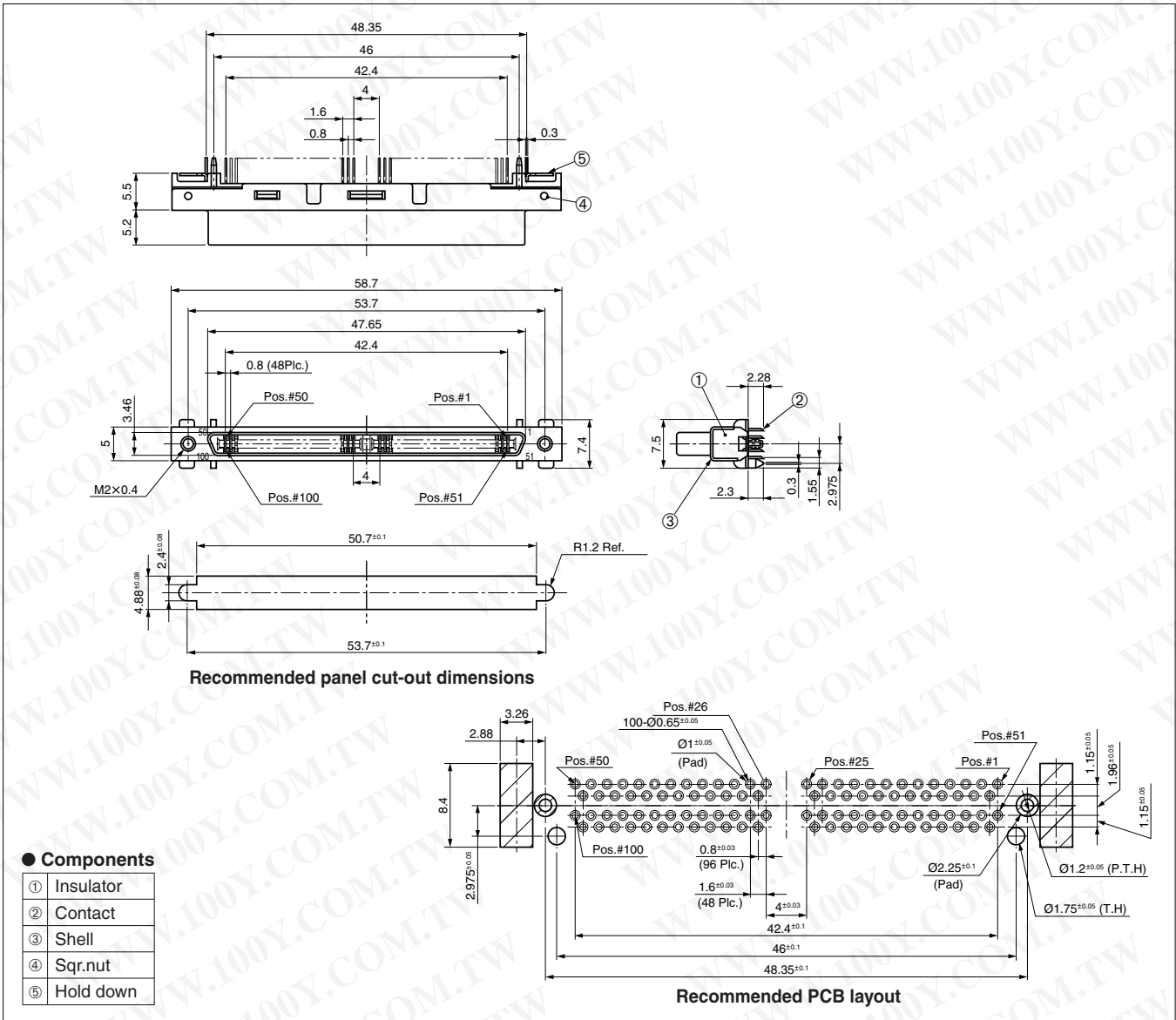

Mating connector: HDRA series, male connector