

Ribbon Cable connector Compliant with MIL Standard

HIF3B Series

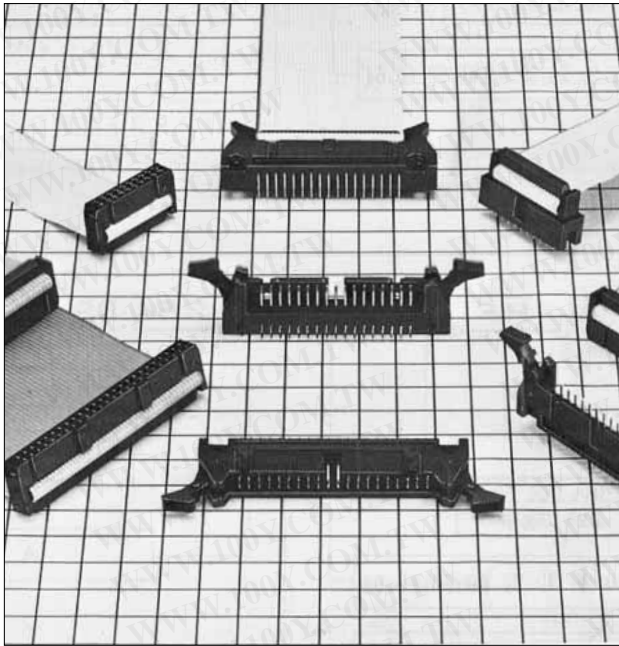

■Features

1. Product Compliant with MIL Standard

HIF3B series has been developed as a product compliant with MIL standard, and used for wide applications.

2. UL Approval Product

HIF3B series connectors are UL approved.

3. Mechanism to Prevent Mis-insertion

This connector is equipped with the mechanism to prevent Mis-insertion as follows.

- ① The system provides the convex area to insert the guide-key on the pin header side, and to guide it in combination with the socket convex area (MIL standard).
- ② The system embeds and guides the polarizing key in the socket holes.

4. Applicable Cable AWG#28

The applicable cable is UL2651 AWG#28 flat cable (7 cores./0.127mm, jacket dia. 0.9±0.1mm).

■Product Specifications

Rating	Current rating : 1A Voltage rating : 200V AC	Operating Temperature Range : -55 to +85°C (Note 1) Operating Moisture Range : 40 to 80%	Storage Temperature Range : -10 to +60°C (Note 2) Storage Humidity Range : 40 to 70% (Note 2)
--------	---	---	--

Item	Specification	Condition
1. Insulation Resistance	1000M ohms min.	500V DC
2. Withstanding voltage	No flashover or insulation breakdown.	650V AC/1 minute
3. Contact Resistance	15m ohms max.	0.1A
4. Vibration	No electrical discontinuity of 1μs or more	Frequency: 10 to 55 Hz, single amplitude of 0.75 mm, 2 hours in each of the 3 directions.
5. Humidity (Steady state)	Insulation resistance: 1000M ohms min.	96 hours at temperature of 40°C and humidity of 90% to 95%
6. Temperature Cycle	No damage, cracks, or parts looseness.	(-55°C: 30 minutes → 15 to 35°C: 5 minutes max. 125°C: 30 minutes → 15 to 35°C: 5 minutes max.) 5 cycles
7. Durability (Mating/un-mating)	Contact resistance: 15m ohms max.	500 cycles
8. Resistance to Soldering heat	No deformation of components affecting performance.	Solder bath: 260°C for 10 seconds Manual soldering: 360°C for 5 seconds

Note 1: Includes temperature rise caused by current flow.

Note 2: The term "storage" refers to products stored for long period of time prior to mounting and use. Operating Temperature Range and Humidity range covers non conducting condition of installed connectors in storage, shipment or during transportation.

Note 3: Information contained in this catalog represents general requirements for this Series. Contact us for the drawings and specifications for a specific part number shown.

Note 4: Please note that there is a risk of deforming the lock when an excessive load is applied to the inside.

■Material

Part	Material	Finish	Remarks
Insulator	PBT	Black	UL94V-0
Socket Contact	Beryllium copper	Connection area Gold plated	—————
Pin header contact	Brass	Selective Gold plated	—————

勝特力材料 886-3-5753170
 勝特力电子(上海) 86-21-34970699
 勝特力电子(深圳) 86-755-83298787
[Http://www.100y.com.tw](http://www.100y.com.tw)

■ Ordering Information

● Socket

HIF **3B** - ***** **D** - **2.54** **R**

① ② ③ ④ ⑤ ⑥

① Series Name	: HIF
② Series No.	: 3B, 3BA, 3BB (50, 60, 64 contacts only)
③ Number of contacts	: 6,10,14,16, 20, 26, 30, 34, 40, 50, 60, 64
④ Contact alignment	: D : Double
⑤ Contact pitch	: 2.54mm
⑥ Connection type	R : ID type

● Pin Header

HIF **3B** - ***** **P** **A** - **2.54** **DS**

① ② ③ ④ ⑤ ⑥ ⑦

① Series Name	: HIF
② Series No.	: 3B : (14 contacts not included) 3BC: (10 contacts only) 3BA, 3BB: (50, 60, 64 contacts only) 3BD: (10 contacts only)
③ Number of contacts	: 6,10,14,16, 20, 26, 30, 34, 40, 50, 60, 64
④ P	: Pin header
⑤ A	: Selective gold plated
⑥ Contact pitch	: 2.54mm
⑦ Contact style	DS : Right angle type DSA : Straight type

■Socket (With guide to prevent mis-insertion)

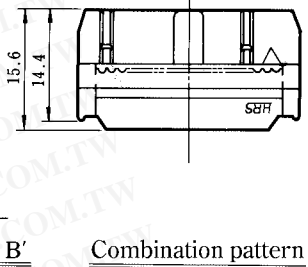
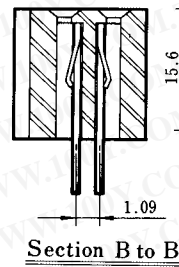
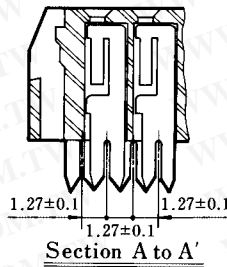

Body

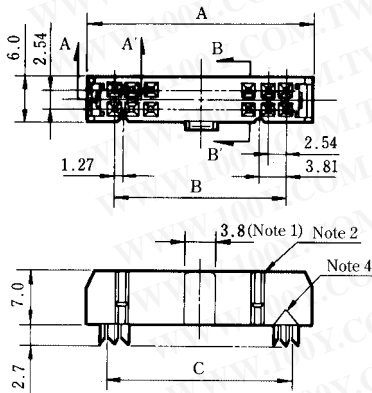

Protector

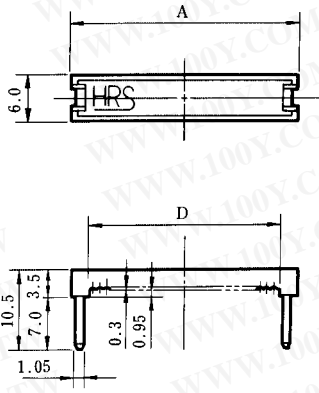

Clamp

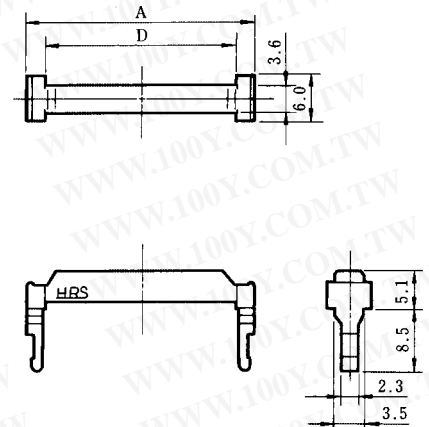

Note1, Note2: The number of polarizing keys and polarizing keyways changes according to products. Refer to the list as shown below.
 Note3: The 50, 60 and 64 contact connector contain two types of polarizing guides. Use the products, referring to Notes 1 and 2.
 Note4: The 6 contact has no polarizing mark.

Unit:mm

Part Number	CL No.	Number of Contacts	A	B	C	D	Polarizing Guide (Note 1)	Polarizing Keyway (Note 2)	RoHS
HIF3BA- 6D-2.54R	610-0032-3	6	12.19	5.08	6.35	7.72	One at center	None	YES
HIF3BA-10D-2.54R	610-0021-7	10	17.27	10.16	11.43	12.8		None	
★ HIF3BA-14D-2.54R	610-0022-0	14	22.35	15.24	16.51	17.88		One on left side	
★ HIF3BA-16D-2.54R	610-0023-2	16	24.89	17.78	19.05	20.42		One on left side	
★ HIF3BA-20D-2.54R	610-0024-5	20	29.97	22.86	24.13	25.5		One on right and left sides, resp.	
★ HIF3BA-26D-2.54R	610-0025-8	26	37.59	30.48	31.75	33.12		One at center	
★ HIF3BA-30D-2.54R	610-0026-0	30	42.67	35.56	36.83	38.2		One at center	
★ HIF3BA-34D-2.54R	610-0027-3	34	47.75	40.64	41.91	43.28		One at center	
★ HIF3BA-40D-2.54R	610-0028-6	40	55.37	48.26	49.53	50.9		One on right and left sides, resp.	
★ HIF3BA-50D-2.54R	610-0029-9	50	68.07	60.96	62.23	63.6		One at center	
★ HIF3BB-50D-2.54R	610-0041-4	50	68.07	60.96	62.23	63.6		One on right and left sides, resp.	
★ HIF3BA-60D-2.54R	610-0030-8	60	80.77	73.66	74.93	76.3		One at center	
★ HIF3BB-60D-2.54R	610-0042-7	60	80.77	73.66	74.93	76.3		One on right and left sides, resp.	
★ HIF3BA-64D-2.54R	610-0031-0	64	85.85	78.74	80.01	81.38		One at center	
★ HIF3BB-64D-2.54R	610-0043-0	64	85.85	78.74	80.01	81.38	One on right and left sides, resp.		

The products marked with ★ comply with MIL standard.

Socket

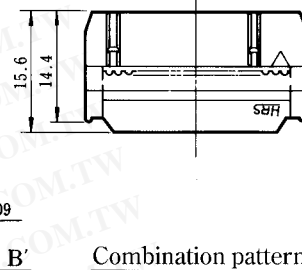
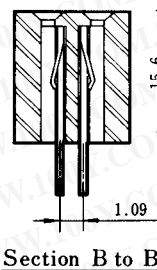
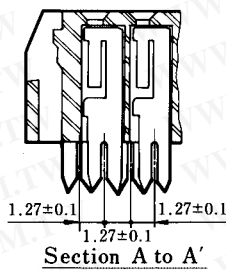

Body

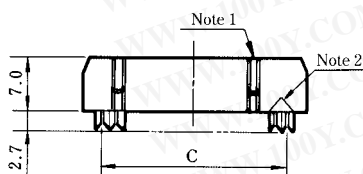
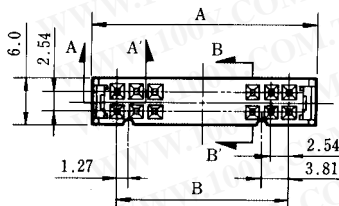

Protector

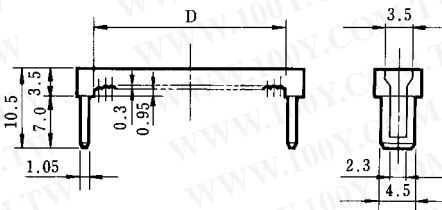
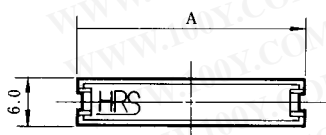

Clamp

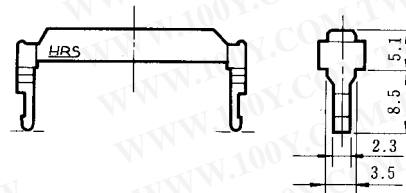
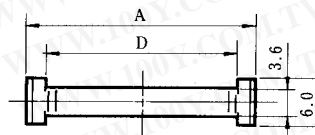

Note1: The number of polarizing keys and polarizing keyways changes according to products. For details, refer to the list as shown below.
 Note2: The 6 contact has no polarizing mark.

Unit:mm

Part Number	CL No.	Number of Contacts	A	B	C	D	Polarizing Guide (Note 1)	RoHS
HIF3B- 6D-2.54R	610-0012-6	6	12.19	5.08	6.35	7.72	None	YES
★ HIF3B-10D-2.54R	610-0001-0	10	17.27	10.16	11.43	12.80	One on left side	
★ HIF3B-14D-2.54R	610-0002-2	14	22.35	15.24	16.51	17.88		
★ HIF3B-16D-2.54R	610-0003-5	16	24.89	17.78	19.05	20.42	One on right and left sides, resp.	
★ HIF3B-20D-2.54R	610-0004-8	20	29.97	22.86	24.13	25.50		
★ HIF3B-26D-2.54R	610-0005-0	26	37.59	30.48	31.75	33.12		
★ HIF3B-30D-2.54R	610-0006-3	30	42.67	35.56	36.83	38.2		
★ HIF3B-34D-2.54R	610-0007-6	34	47.75	40.64	41.91	43.28		
★ HIF3B-40D-2.54R	610-0008-9	40	55.37	48.26	49.53	50.90		
★ HIF3B-50D-2.54R	610-0009-1	50	68.07	60.96	62.23	63.6		
★ HIF3B-60D-2.54R	610-0010-0	60	80.77	73.66	74.93	76.3		
★ HIF3B-64D-2.54R	610-0011-3	64	85.85	78.74	80.01	81.38		

The products marked with ★ comply with MIL standard.

■ Four Wall Angle Through hole

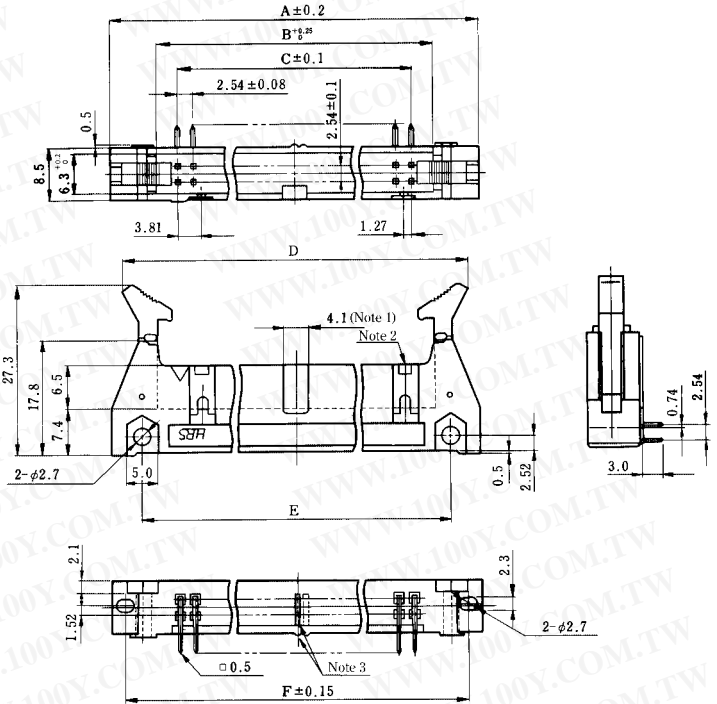
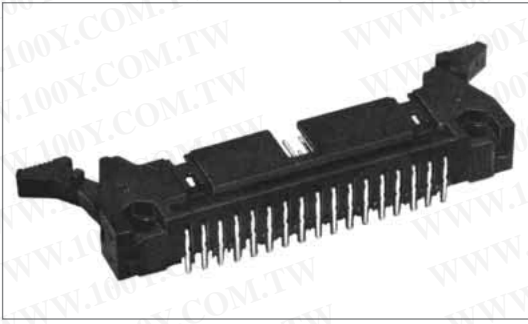

◆ PCB mounting pattern

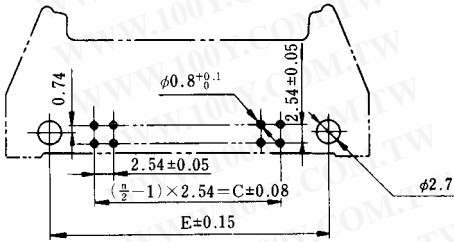

■ n=number of contacts

- Note 1, Note 2: The number of polarizing slot and key installed positions changes according to products. Refer to the list as shown below.
- Note 3: The spacer moves to the right according to the number of contacts.
- Note 4: The 10, 50, 60 and 64 contact connectors contain two types of polarizing slots.
Use products, referring to (Note 1) (Note 2).

Unit:mm

Part Number	CL No.	Number of Contacts	A	B	C	D	E	F	Polarizing Slot (Note 1)	Polarizing Key Install (Note 2)	RoHS
★ HIF3BA-10PA-2.54DS(71)	610-0091-2(71)	10	32.0	17.5	10.16	28.14 MAX51.1	21.8	27.9	None	One on right side	YES
HIF3BD-10PA-2.54DS(71)	610-0171-0(71)	10	32.0	17.5	10.16	28.14 MAX51.1	21.8	27.9	None	None	
★ HIF3BA-14PA-2.54DS(71)	610-0092-5(71)	14	37.1	22.6	15.24	33.24 MAX56.2	26.9	33.0	One at center	One on right side	
★ HIF3BA-16PA-2.54DS(71)	610-0093-8(71)	16	39.6	25.1	17.78	35.74 MAX58.7	29.5	35.5	One at center	One on right and left sides, resp.	
★ HIF3BA-20PA-2.54DS(71)	610-0094-0(71)	20	44.7	30.2	22.86	40.84 MAX63.8	34.5	40.6	One at center	One on right and left sides, resp.	
★ HIF3BA-26PA-2.54DS(71)	610-0095-3(71)	26	52.3	37.8	30.48	48.44 MAX71.4	42.2	48.3	One at center	One on right and left sides, resp.	
★ HIF3BA-30PA-2.54DS(71)	610-0096-6(71)	30	57.4	42.9	35.56	53.54 MAX76.5	47.2	53.3	One at center	One on right and left sides, resp.	
★ HIF3BA-34PA-2.54DS(71)	610-0097-9(71)	34	62.5	48.0	40.64	58.64 MAX81.6	52.3	58.4	One at center	One on right and left sides, resp.	
★ HIF3BA-40PA-2.54DS(71)	610-0098-1(71)	40	70.1	55.6	48.26	66.24 MAX89.2	59.9	66.0	One at center	One on right and left sides, resp.	
★ HIF3BA-50PA-2.54DS(71)	610-0099-4(71)	50	82.8	68.3	60.96	78.94 MAX101.9	72.6	78.7	One on right and left sides, resp.	One on right and left sides, resp.	
★ HIF3BB-50PA-2.54DS(71)	610-0131-5(71)	50	82.8	68.3	60.96	78.94 MAX101.9	72.6	78.7	One at center	One on right and left sides, resp.	
★ HIF3BA-60PA-2.54DS(71)	610-0100-1(71)	60	95.5	81.0	73.66	91.64 MAX114.6	85.3	91.4	One on right and left sides, resp.	One on right and left sides, resp.	
★ HIF3BB-60PA-2.54DS(71)	610-0132-8(71)	60	95.5	81.0	73.66	91.64 MAX114.6	85.3	91.4	One at center	One on right and left sides, resp.	
★ HIF3BA-64PA-2.54DS(71)	610-0101-4(71)	64	100.6	86.1	78.74	96.74 MAX119.7	90.4	96.5	One on right and left sides, resp.	One on right and left sides, resp.	
★ HIF3BB-64PA-2.54DS(71)	610-0133-0(71)	64	100.6	86.1	78.74	96.74 MAX119.7	90.4	96.5	One at center	One on right and left sides, resp.	

The products marked with ★ comply with MIL standard.

Four-Wall Straight Through hole

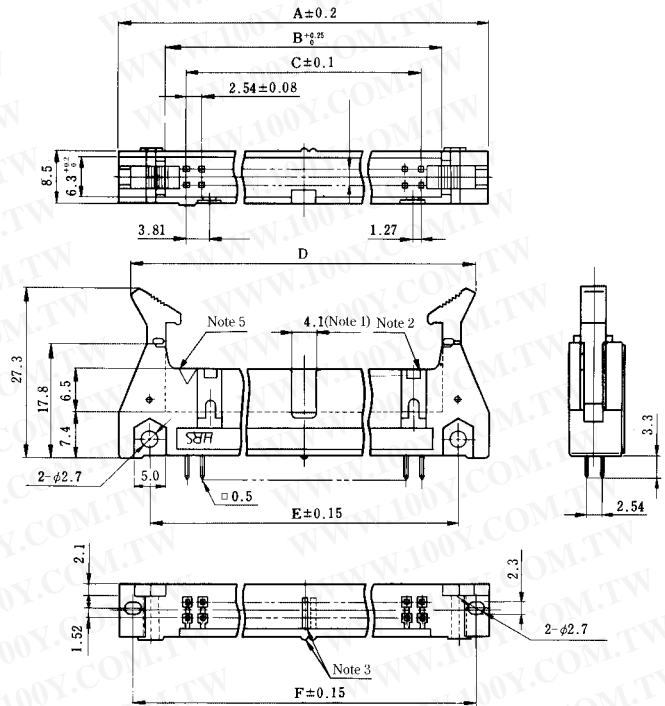
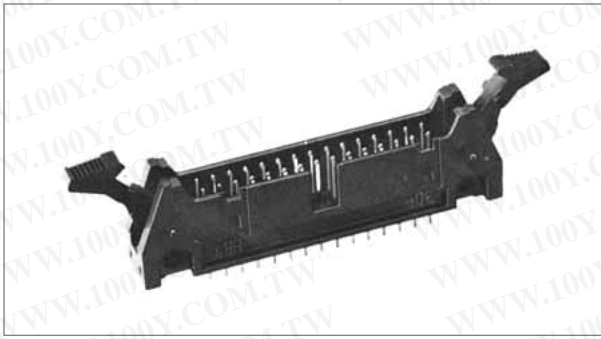

PCB mounting pattern

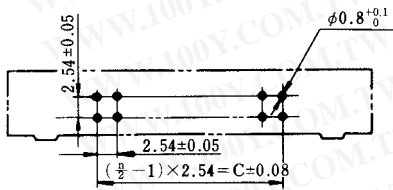

n=number of contacts

- Note 1, Note 2: The number of polarizing slot and key installed positions changes according to products. Refer to the list as shown below.
- Note 3: The spacer moves to the right according to the number of contacts.
- Note 4: The 10, 50, 60 and 64 contact connectors contain two types of polarizing slots.
Use products, confirming (Note 1) (Note 2).
- Note 5: The 6 contact has no polarity mark.

Unit:mm

Part Number	CL No.	Number of Contacts	A	B	C	D	E	F	Polarizing Slot (Note 1)	Polarizing Key Install (Note 2)	RoHS
★ HIF3-6PA-2.54DSA(71)	562-0503-9-71	6	26.92	12.42	5.08	$\frac{23.06}{MAX46.02}$	16.7	22.82	One at center	None	YES
HIF3BA-10PA-2.54DSA(71)	610-0111-8-71	10	32.0	17.5	10.16	$\frac{28.14}{MAX51.1}$	21.8	27.9	None	One on right side	
★ HIF3BD-10PA-2.54DSA(71)	610-0181-3-71	10	32.0	17.5	10.16	$\frac{28.14}{MAX51.1}$	21.8	27.9	None	None	
★ HIF3BA-14PA-2.54DSA(71)	610-0112-0-71	14	37.1	22.6	15.24	$\frac{33.24}{MAX56.2}$	26.9	33.0	One at center	One on right side	
★ HIF3BA-16PA-2.54DSA(71)	610-0113-3-71	16	39.6	25.1	17.78	$\frac{35.74}{MAX58.7}$	29.5	35.5			
★ HIF3BA-20PA-2.54DSA(71)	610-0114-6-71	20	44.7	30.2	22.86	$\frac{40.84}{MAX63.8}$	34.5	40.6			
★ HIF3BA-26PA-2.54DSA(71)	610-0115-9-71	26	52.3	37.8	30.48	$\frac{48.44}{MAX71.4}$	42.2	48.3			
★ HIF3BA-30PA-2.54DSA(71)	610-0116-1-71	30	57.4	42.9	35.56	$\frac{53.54}{MAX76.5}$	47.2	53.3	One on right and left sides, resp.	One on right and left sides, resp.	
★ HIF3BA-34PA-2.54DSA(71)	610-0117-4-71	34	62.5	48.0	40.64	$\frac{58.64}{MAX81.6}$	52.3	58.4			
★ HIF3BA-40PA-2.54DSA(71)	610-0118-7-71	40	70.1	55.6	48.26	$\frac{66.24}{MAX89.2}$	59.9	66.0			
★ HIF3BA-50PA-2.54DSA(71)	610-0119-0-71	50	82.8	68.3	60.96	$\frac{78.94}{MAX101.9}$	72.6	78.7			
★ HIF3BB-50PA-2.54DSA(71)	610-0141-9-71	50	82.8	68.3	60.96	$\frac{78.94}{MAX101.9}$	72.6	78.7	One at center	One on right and left sides, resp.	
★ HIF3BA-60PA-2.54DSA(71)	610-0120-9-71	60	95.5	81.0	73.66	$\frac{91.64}{MAX114.6}$	85.3	91.4	One on right and left sides, resp.		
★ HIF3BB-60PA-2.54DSA(71)	610-0142-1-71	60	95.5	81.0	73.66	$\frac{91.64}{MAX114.6}$	85.3	91.4	One at center		
★ HIF3BA-64PA-2.54DSA(71)	610-0121-1-71	64	100.6	86.1	78.74	$\frac{96.74}{MAX119.7}$	90.4	96.5	One on right and left sides, resp.		
★ HIF3BB-64PA-2.54DSA(71)	610-0143-4-71	64	100.6	86.1	78.74	$\frac{96.74}{MAX119.7}$	90.4	96.5	One at center		

The products marked with ★ comply with MIL standard.

Three Wall Angle Type

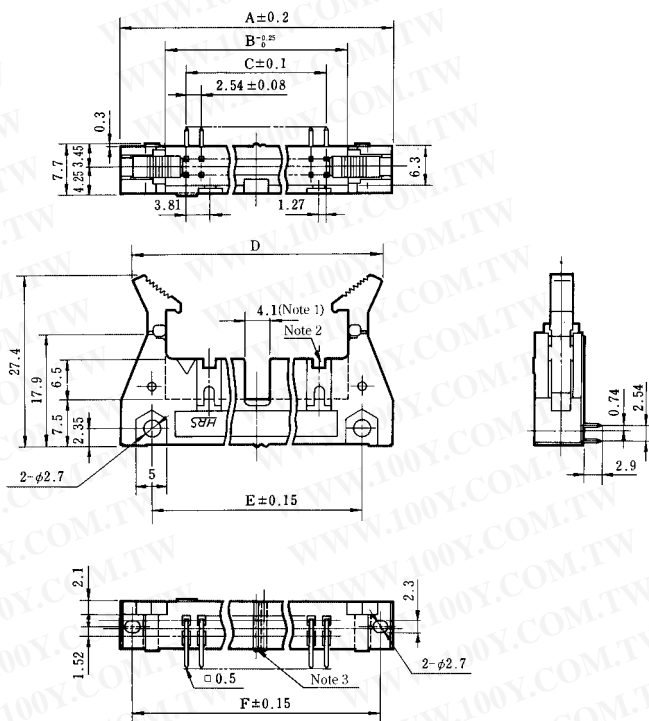

PCB mounting pattern

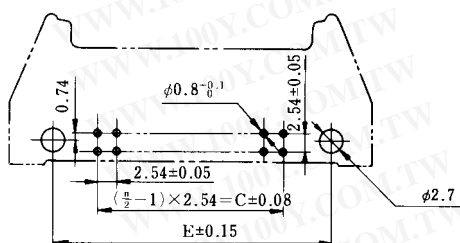

■n=number of contacts

Note 1, Note 2: The number of polarizing slot and key installed positions changes according to products. Refer to the list as shown below.

Note 3: The spacer moves according to the number of contacts.

Note 4: The 10 contact connector consists of two types.

Use products, confirming (Note 1) (Note 2).

Unit:mm

Part Number	CL No.	Number of Contacts	A	B	C	D	E	F	Polarizing Slot (Note 1)	Polarizing Key Install (Note 2)	RoHS
★ HIF3B -10PA-2.54DS(71)	610-0051-8-71	10	32.0	17.5	10.16	28.14 MAX51.1	21.8	27.9	None	One on right side	YES
HIF3BC-10PA-2.54DS(71)	610-0151-2-71	10	32.0	17.5	10.16	28.14 MAX51.1	21.8	27.9	None	None	
★ HIF3B -16PA-2.54DS(71)	610-0052-0-71	16	39.6	25.1	17.78	35.74 MAX58.7	29.5	35.5	One at center	One on right and left sides, resp.	
★ HIF3B -20PA-2.54DS(71)	610-0053-3-71	20	44.7	30.2	22.86	40.84 MAX63.8	34.5	40.6			
★ HIF3B -26PA-2.54DS(71)	610-0054-6-71	26	52.3	37.8	30.48	48.44 MAX71.4	42.2	48.3			
★ HIF3B -30PA-2.54DS(71)	610-0055-9-71	30	57.4	42.9	35.56	53.54 MAX76.5	47.2	53.3			
★ HIF3B -34PA-2.54DS(71)	610-0056-1-71	34	62.5	48.0	40.64	58.64 MAX81.6	52.3	58.4			
★ HIF3B -40PA-2.54DS(71)	610-0057-4-71	40	70.1	55.6	48.26	66.24 MAX89.2	59.9	66.0			
★ HIF3B -50PA-2.54DS(71)	610-0058-7-71	50	82.8	68.3	60.96	78.94 MAX101.9	72.6	78.7	One on right and left sides, resp.		
★ HIF3B -60PA-2.54DS(71)	610-0059-0-71	60	95.5	81.0	73.66	91.64 MAX114.6	85.3	91.4			
★ HIF3B -64PA-2.54DS(71)	610-0060-9-71	64	100.6	86.1	78.74	96.74 MAX119.7	90.4	96.5			

The products marked with ★ comply with MIL standard.

Three Wall Straight Through hole

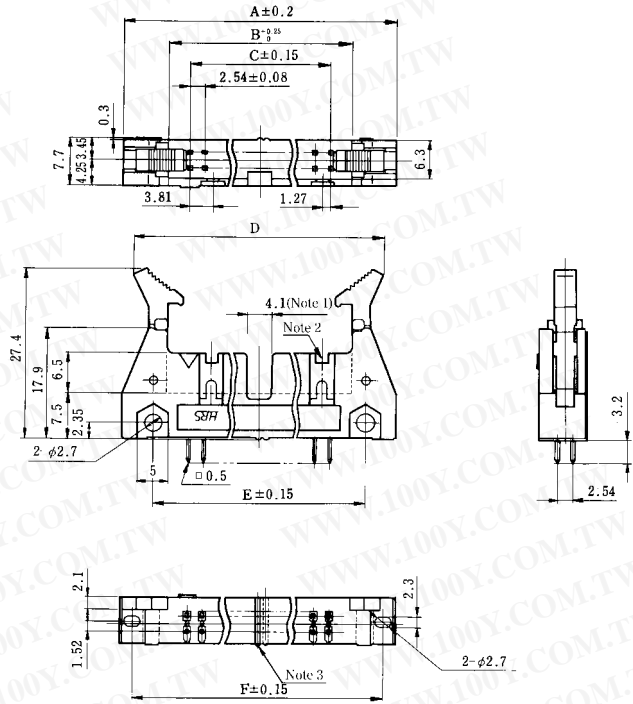
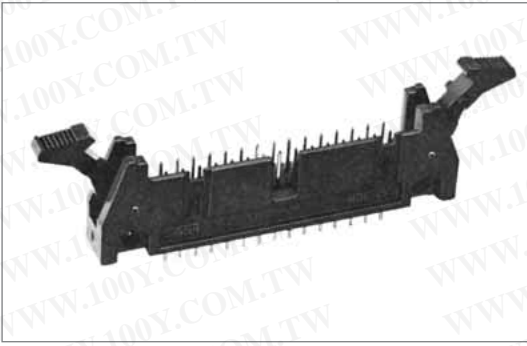

PCB mounting pattern

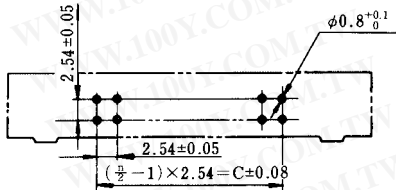

n=number of contacts

Note1, Note2: The number of polarizing slot and key installed positions changes according to products. Refer to the list as shown below.

Note3: The spacer moves to the right according to the number of contacts.

Note4: The 10 contact connector consists of two types. Use products, referring to (Note 1) and (Note 2).

Unit:mm

Part Number	CL No.	Number of Contacts	A	B	C	D	E	F	Polarizing Slot (Note 1)	Polarizing Key Install (Note 2)	RoHS
★ HIF3B -10PA-2.54DSA(71)	610-0071-5-71	10	32.0	17.5	10.16	28.14 MAX51.1	21.8	27.9	None	One on right side	YES
HIF3BC-10PA-2.54DSA(71)	610-0161-6-71	10	32.0	17.5	10.16	28.14 MAX51.1	21.8	27.9	None	None	
★ HIF3B -16PA-2.54DSA(71)	610-0072-8-71	16	39.6	25.1	17.78	35.74 MAX58.7	29.5	35.5	One at center	One on right and left sides, resp.	
★ HIF3B -20PA-2.54DSA(71)	610-0073-0-71	20	44.7	30.2	22.86	40.84 MAX63.8	34.5	40.6			
★ HIF3B -26PA-2.54DSA(71)	610-0074-3-71	26	52.3	37.8	30.48	48.44 MAX71.4	42.2	48.3			
★ HIF3B -30PA-2.54DSA(71)	610-0075-6-71	30	57.4	42.9	35.56	53.54 MAX76.5	47.2	53.3			
★ HIF3B -34PA-2.54DSA(71)	610-0076-9-71	34	62.5	48.0	40.64	58.64 MAX81.6	52.3	58.4			
★ HIF3B -40PA-2.54DSA(71)	610-0077-1-71	40	70.1	55.6	48.26	66.24 MAX88.2	59.9	66.0			
★ HIF3B -50PA-2.54DSA(71)	610-0078-4-71	50	82.8	68.3	60.96	78.94 MAX101.9	72.6	78.7			
★ HIF3B -60PA-2.54DSA(71)	610-0079-7-71	60	95.5	81.0	73.66	91.64 MAX114.6	85.3	91.4			
★ HIF3B -64PA-2.54DSA(71)	610-0080-6-71	64	100.6	86.1	78.74	96.74 MAX119.7	90.4	96.5			

The products marked with ★ comply with MIL standard.

■ Four Wall Wrapping Type

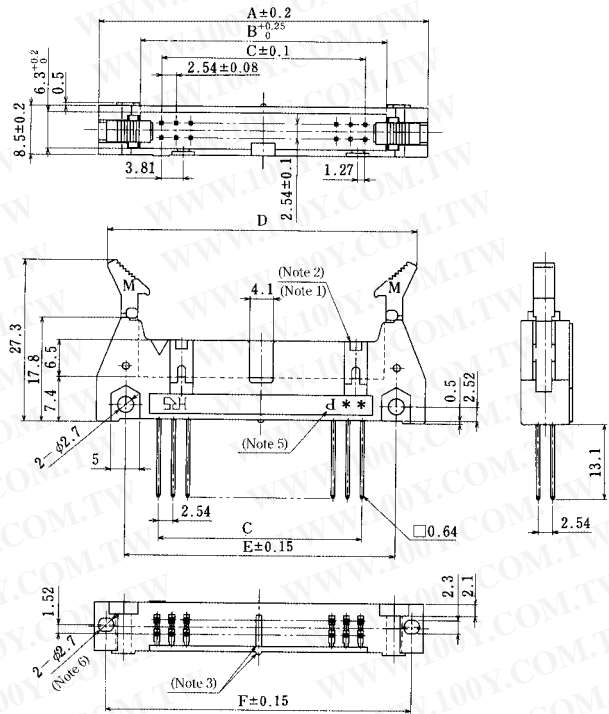
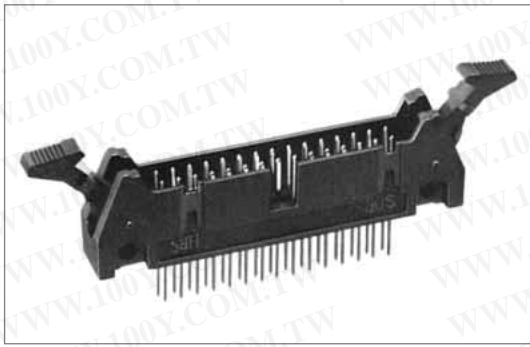

◆ PCB mounting pattern

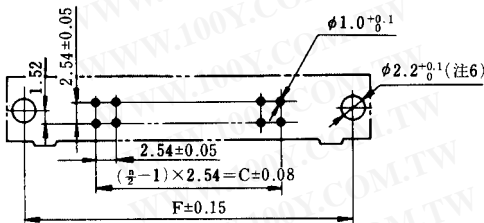

■ n=number of contacts

Note 1, Note 2. The number of polarizing slot and key installed positions changes according to products. Refer to the list as shown below.

Note 3. The spacer moves to the right according to the number of contacts.

Note 4. The 10, 50, 60 and 64 contact connectors consists of two types. Use products, confirming (Note 1) (Note 2).

Note 5. The mark * indicates the number of contacts.

Note 6. The nut built-in specification product is also provided.

The product can be fixed by M2 screws from the rear side.

Use the screw of (board thickness) +4 mm under the neck.

Unit:mm

Part Number	CL No.	Number of Contacts	A	B	C	D	E	F	Polarizing Slot (Note 1)	Polarizing Key Install (Note 2)	RoHS
★ HIF3BA-10P-2.54W	610-0503-8	10	32.0	17.5	10.16	28.14 MAX51.1	21.8	27.9	None	One on right side	YES
HIF3BD-10P-2.54W	610-0492-3	10	32.0	17.5	10.16	28.14 MAX51.1	21.8	27.9	None	None	
★ HIF3BA-14P-2.54W	610-0493-6	14	37.1	22.6	15.24	33.24 MAX56.2	26.9	33.0	One at center	One on right side	
★ HIF3BA-16P-2.54W	610-0494-9	16	39.6	25.1	17.78	35.74 MAX58.7	29.5	35.5	One at center	One on right side	
★ HIF3BA-20P-2.54W	610-0495-1	20	44.7	30.2	22.86	40.84 MAX63.8	34.5	40.6	One at center	One on right side	
★ HIF3BA-26P-2.54W	610-0496-4	26	52.3	37.8	30.48	48.44 MAX71.4	42.2	48.3	One at center	One on right side	
★ HIF3BA-30P-2.54W	610-0497-7	30	57.4	42.9	35.56	53.54 MAX76.5	47.2	53.3	One at center	One on right side	
★ HIF3BA-34P-2.54W	610-0498-0	34	62.5	48.0	40.64	58.64 MAX81.6	52.3	58.4	One at center	One on right side	
★ HIF3BA-40P-2.54W	610-0499-2	40	70.1	55.6	48.26	66.24 MAX89.2	59.9	66.0	One at center	One on right side	
★ HIF3BA-50P-2.54W	610-0504-0	50	82.8	68.3	60.96	78.94 MAX101.9	72.6	78.7	One on right and left sides, resp.	One on right and left sides, resp.	
★ HIF3BB-50P-2.54W	610-0500-0	50	82.8	68.3	60.96	78.94 MAX101.9	72.6	78.7	One at center	One on right and left sides, resp.	
★ HIF3BA-60P-2.54W	610-0505-3	60	95.5	81.0	73.66	91.64 MAX114.6	85.3	91.4	One on right and left sides, resp.	One on right and left sides, resp.	
★ HIF3BB-60P-2.54W	610-0501-2	60	95.5	81.0	73.66	91.64 MAX114.6	85.3	91.4	One at center	One on right and left sides, resp.	
★ HIF3BA-64P-2.54W	610-0506-6	64	100.6	86.1	78.74	96.74 MAX119.7	90.4	96.5	One on right and left sides, resp.	One on right and left sides, resp.	
★ HIF3BB-64P-2.54W	610-0502-5	64	100.6	86.1	78.74	96.74 MAX119.7	90.4	96.5	One at center	One on right and left sides, resp.	

The products marked with ★ comply with MIL standard.

Four Wall Straight Through hole

[Flux Blister Prevention Type]

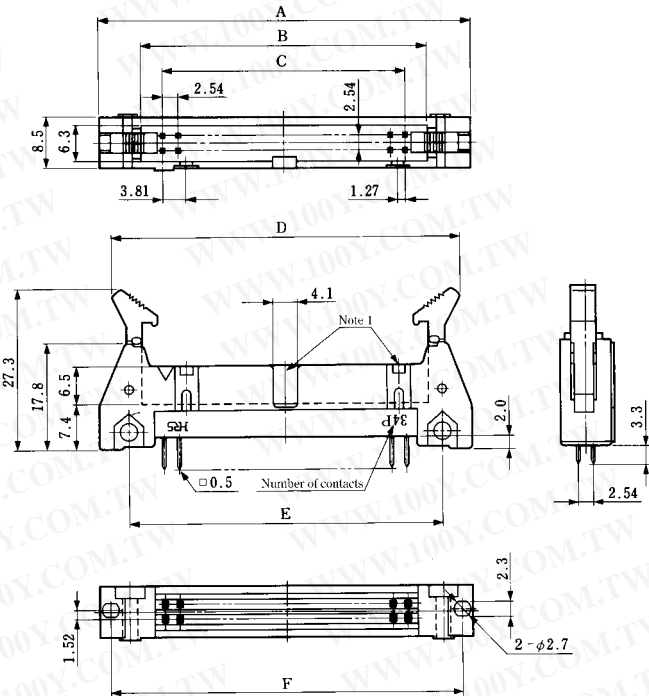
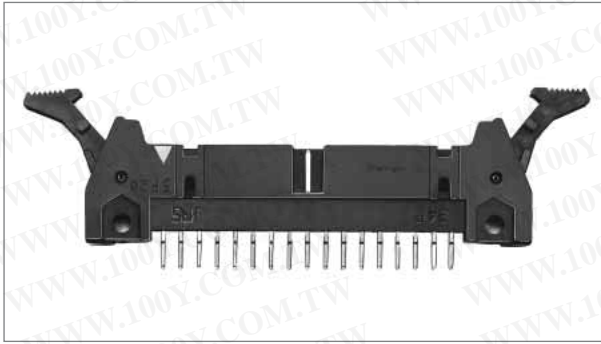

PCB mounting pattern

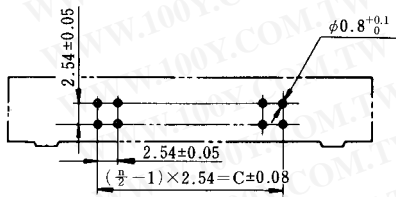

n=number of contacts

Note1: The number of polarizing slot and key installed positions changes according to products. Refer to the list as shown below.

Unit:mm

Part Number	CL No.	Number of Contacts	A	B	C	D	E	F	Polarizing Slot	Polarizing Key Install	RoHS
★ HIF3CA-10PA-2.54DSA(71)	610-0701-1-71	10	32.0	17.5	10.16	28.14 MAX51.1	21.8	27.9	None	One on right side	YES
HIF3CD-10PA-2.54DSA(71)	610-0722-1-71	10	32.0	17.5	10.16	28.14 MAX51.1	21.8	27.9		None	
★ HIF3CA-16PA-2.54DSA(71)	610-0703-7-71	16	39.6	25.1	17.78	35.74 MAX58.7	29.5	35.5	One at center	One on right and left sides, resp.	
★ HIF3CA-20PA-2.54DSA(71)	610-0704-0-71	20	44.7	30.2	22.86	40.84 MAX63.8	34.5	40.6			
★ HIF3CA-26PA-2.54DSA(71)	610-0705-2-71	26	52.3	37.8	30.48	48.44 MAX71.4	42.2	48.3			
★ HIF3CA-30PA-2.54DSA(71)	610-0706-5-71	30	57.4	42.9	35.56	53.54 MAX76.5	47.2	53.3			
★ HIF3CA-34PA-2.54DSA(71)	610-0707-8-71	34	62.5	48.0	40.64	58.64 MAX81.6	52.3	58.4			
★ HIF3CA-40PA-2.54DSA(71)	610-0708-0-71	40	70.1	55.6	48.26	66.24 MAX89.2	59.9	66.0			
★ HIF3CA-50PA-2.54DSA(71)	610-0709-3-71	50	82.8	68.3	60.96	78.94 MAX101.9	72.6	78.7	One on right and left sides, resp.		
★ HIF3CB-50PA-2.54DSA(71)	610-0721-9-71	50	82.8	68.3	60.96	78.94 MAX101.9	72.6	78.7	One at center		
★ HIF3CB-60PA-2.54DSA(71)	610-0723-4-71	60	95.5	81.0	73.66	91.64 MAX114.6	85.3	91.4			
★ HIF3CB-64PA-2.54DSA(71)	610-0724-7-71	64	100.6	86.1	78.74	96.74 MAX119.7	90.4	96.5			

The products marked with ★ comply with MIL standard.

Two Stage Staking Right Angle Through hole

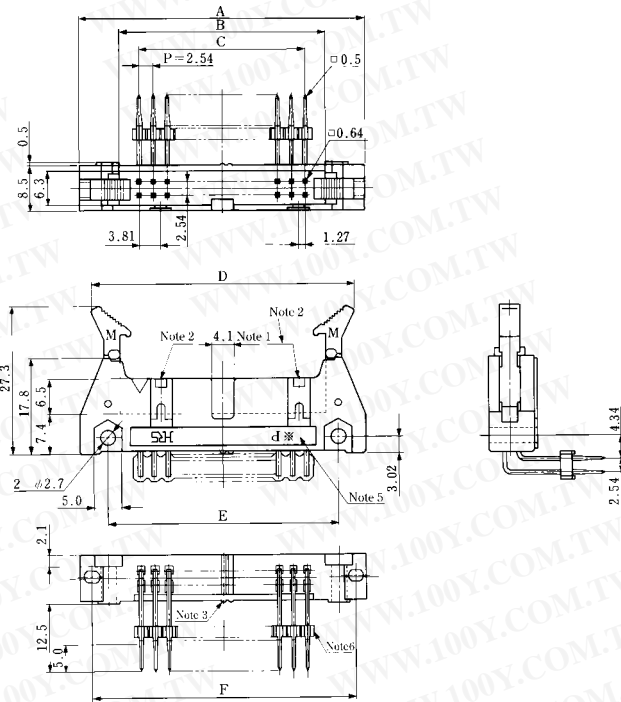

Note 1, Note 2: The number of polarizing slot and key installed positions changes according to products. Refer to the list as shown below.

Note 3: The spacer moves to the right according to the number of contacts.

Note 4: The 10, 50, 60 and 64 contact connectors consists of two types.
Use products, confirming (Note 1) (Note 2).

Note 5: The mark * indicates the number of contacts.

Note 6: The locator is located optionally.

Unit:mm

Part Number	CL No.	Number of Contacts	A	B	C	D	E	F	Polarizing Slot (Note 1)	Polarizing Key Install (Note 2)	RoHS
★ HIF3BA-10PA-2.54WB(71)	610-1502-0-71	10	32.0	17.5	10.16	28.14 MAX51.1	21.8	27.9	None	One on right side	YES
HIF3BD-10PA-2.54WB(71)	610-1503-3-71	10	32.0	17.5	10.16	28.14 MAX51.1	21.8	27.9			
★ HIF3BA-16PA-2.54WB(71)	610-1505-9-71	16	39.6	25.1	17.78	35.74 MAX58.7	29.5	35.5	One at center	One on right and left sides, resp.	
★ HIF3BA-20PA-2.54WB(71)	610-1506-1-71	20	44.7	30.2	22.86	40.84 MAX63.8	34.5	40.6			
★ HIF3BA-26PA-2.54WB(71)	610-1507-4-71	26	52.3	37.8	30.48	48.44 MAX71.4	42.2	48.3			
★ HIF3BA-30PA-2.54WB(71)	610-1508-7-71	30	57.4	42.9	35.56	53.54 MAX76.5	47.2	53.3			
★ HIF3BA-34PA-2.54WB(71)	610-1509-0-71	34	62.5	48.0	40.64	58.64 MAX81.6	52.3	58.4			
★ HIF3BA-40PA-2.54WB(71)	610-1510-9-71	40	70.1	55.6	48.26	66.24 MAX89.2	59.9	66.0			
★ HIF3BA-50PA-2.54WB(71)	610-1511-1-71	50	82.8	68.3	60.96	78.94 MAX101.9	72.6	78.7	One on right and left sides, resp.		
★ HIF3BB-50PA-2.54WB(71)	610-1512-4-71	50	82.8	68.3	60.96	78.94 MAX101.9	72.6	78.7	One at center		
★ HIF3BA-60PA-2.54WB(71)	610-1513-7-71	60	95.5	81.0	73.66	91.64 MAX114.6	85.3	91.4	One on right and left sides, resp.		
★ HIF3BB-60PA-2.54WB(71)	610-1514-0-71	60	95.5	81.0	73.66	91.64 MAX114.6	85.3	91.4	One at center		
★ HIF3BA-64PA-2.54WB(71)	610-1515-2-71	64	100.6	86.1	78.74	96.74 MAX119.7	90.4	96.5	One on right and left sides, resp.		
★ HIF3BB-64PA-2.54WB(71)	610-1516-5-71	64	100.6	86.1	78.74	96.74 MAX119.7	90.4	96.5	One at center		

The products marked with ★ comply with MIL standard.

◆ Combination Pattern

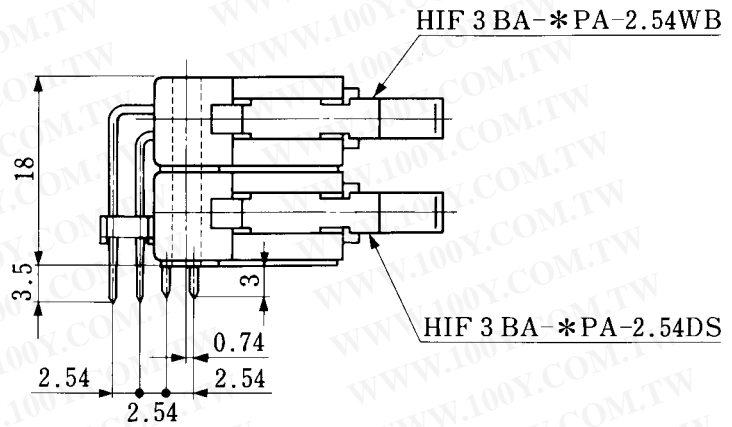

Note : Fix the HIF3-mounting hole spacer by screws between upper stage and lower stage connectors.

◆ PCB mounting pattern

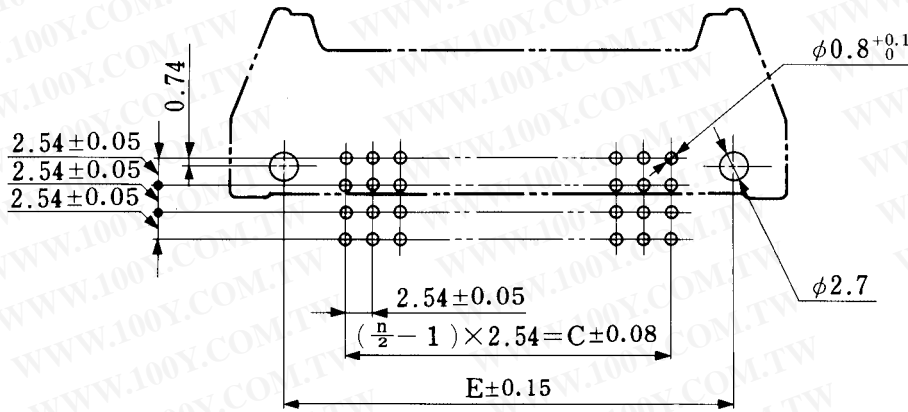

■ Mounting Hole Spacer

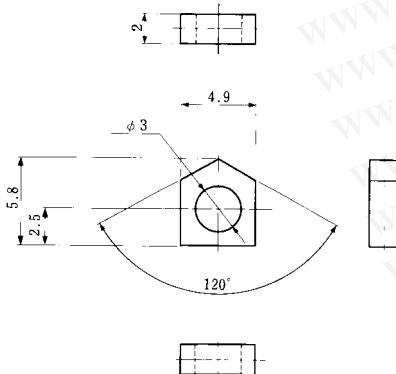

Part Number	CL No.	Finish	RoHS
HIF-3 mounting hole spacer	562-0714-4	PBT Black	YES

Note : 2 pieces are contained in a bag.

◆ Polarizing Key



HIF3B-GK
CL562-0601-8

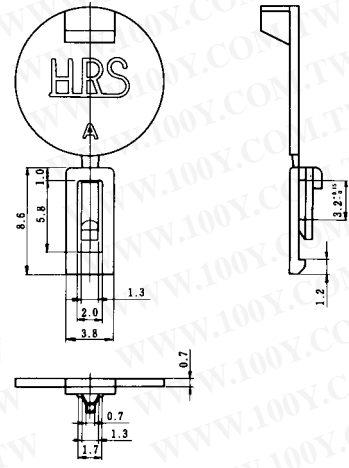

HIF3-GPIN(A)

HIF3BA-GPIN

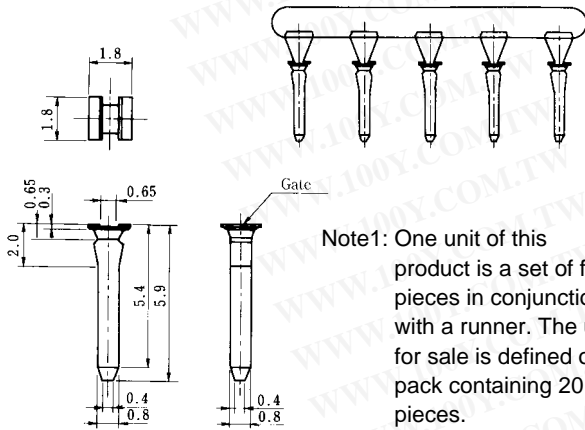

Note1: One unit of this product is a set of five pieces in conjunction with a runner. The unit for sale is defined one pack containing 20 pieces.

Note2: This product is applicable to HIF3A-*D2.54R, HIF3C-*D2.54C and HIF3BA-*D2.54C products.

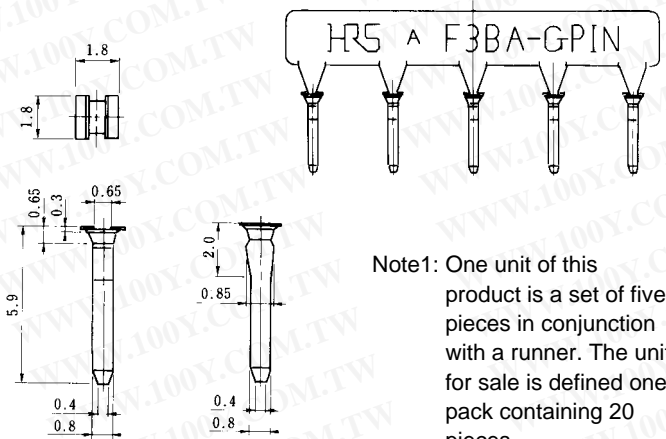

Note1: One unit of this product is a set of five pieces in conjunction with a runner. The unit for sale is defined one pack containing 20 pieces.

Note2: This product is applicable to the HIF3BA-*D2.54R product.

Part Number	CL No.	Material	Remarks	RoHS
HIF3-GPIN(A)	562-0126-6	Poly acetal (white)	A set of 5 pieces	YES

Part Number	CL No.	Material	Remarks	RoHS
HIF3BA-GPIN	612-0500-2	Poly acetal (white)	A set of 5 pieces	YES

◆ HIF3-Multi Clamp



This clamp is used for intermediate connection in the bus-line system, etc. Remove compulsory force from the insulation displacement area of the connector in intermediate connection.

Note: The pin header corresponds to the HIF3BAE series (lock E).

◆ HIF3-*CL Pull Tab



This pull tab is used for the HIF3 series equipped with cable clamp function. Remove all compulsory force, which is loaded on the insulation displacement area of the connector for extraction.

Note: This HIF3-* Pull Tab can not be used for HIF3BA-*PD.

Note: The pin header corresponds to the HIF3BAE series (lock E).



◆ Lock

● Low Profile Lock Pin Header

Lock G

Part Number : HIF3BAG-**-PA-2.54DSA(71)

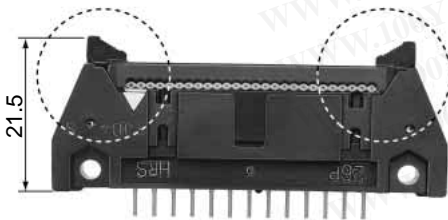

- Low profile type, and used for lock ejection. Connector height is reduced. Since no connector clamp is needed on the cable side, this is used without turning back on the cable side. Take care about this point.

● F Type Lock Pin Header

Lock F

Part Number : HIF3BAG-**-PA-2.54DSA(71)

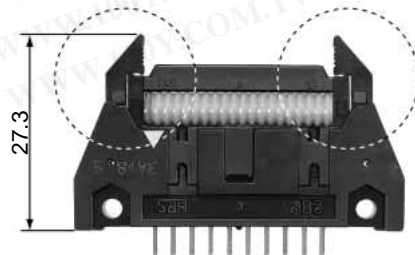

- Locking range more reduced than conventional lock type. Even if connectors are aligned laterally, the mounting space is reduced. Note : The clamp must be replaced for HIF3A socket type 60 contacts only. Take care about this point.

Socket for Crimping

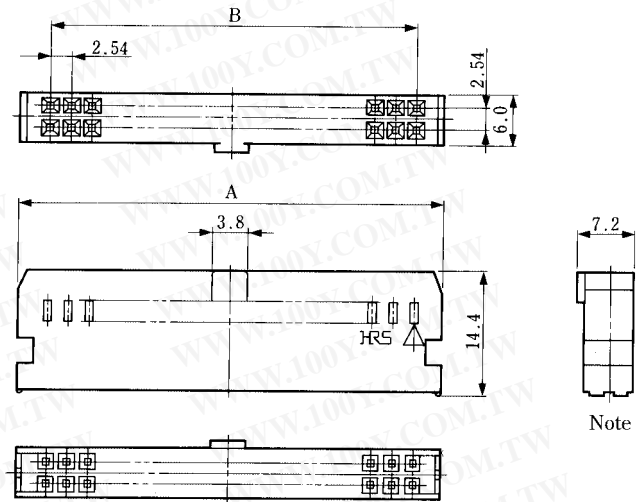

Note

Unit: mm

Part Number	CL No.	Number of Contacts	A	B	Polarizing Guide	RoHS
HIF3BA-10D-2.54C	610-1041-0	10	17.25	10.16	One at center	YES
HIF3BA-14D-2.54C	610-1051-3	14	22.35	15.24		
HIF3BA-16D-2.54C	610-1042-2	16	24.8	17.78		
HIF3BA-20D-2.54C	610-1043-5	20	29.95	22.86		
HIF3BA-26D-2.54C	610-1044-8	26	37.55	30.48		
HIF3BA-30D-2.54C	610-1045-0	30	42.63	35.56		
HIF3BA-34D-2.54C	610-1046-3	34	47.75	40.64		
HIF3BA-50D-2.54C	610-1048-9	50	68.04	60.96	One right and left side, resp.	
HIF3BB-50D-2.54C	610-1061-7				One at center	
HIF3BA-60D-2.54C	610-1049-1	60	80.77	73.66	One right and left side, resp.	
HIF3BB-60D-2.54C	610-1062-0				One at center	
HIF3BA-64D-2.54C	610-1064-5	64	85.85	78.74	One right and left side, resp.	
HIF3BB-64D-2.54C	610-1063-2				One at center	

Note: Some variations may differ from those in above figures.

■Cover Case for Crimping socket

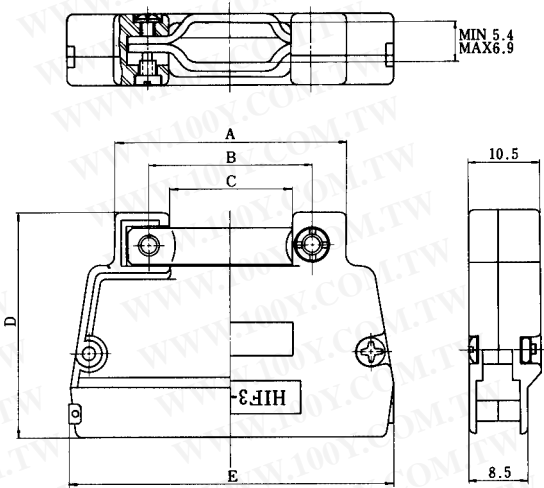

Unit: mm

Part Number	CL No.	Number of Contacts	A	B	C	D	E	RoHS
HIF3-20CV(71)	562-0201-0-71	20	24.5	18.0	12.0	30.5	29.95	YES
HIF3-26CV(71)	562-0202-2-71	26	30.2	20.0	14.0	32.0	37.55	
HIF3-30CV(71)	562-0203-5-71	30	32.2	22.0	16.0	33.0	42.63	
HIF3-34CV(71)	562-0204-8-71	34	34.2	24.0	18.0	33.5	47.75	
HIF3-40CV(71)	562-0205-0-71	40	36.2	26.0	20.0	35.5	55.35	
HIF3-50CV(71)	562-0206-3-71	50	39.2	29.0	23.0	38.0	68.04	
HIF3-60CV(71)	562-0207-6-71	60	42.2	32.0	26.0	40.5	80.77	

Note 1: The type F lock pin header cannot be used for a mating member.

Note 2: Note that the product cannot be used with AWG #20.

Applicable jacket diameters are as described below.

20 contacts: 1.7 mm diameter MAX

26 to 40 contacts: 1.6 mm diameter MAX

50 to 60 contacts: 1.4 mm diameter MAX

Contact for Crimping Socket

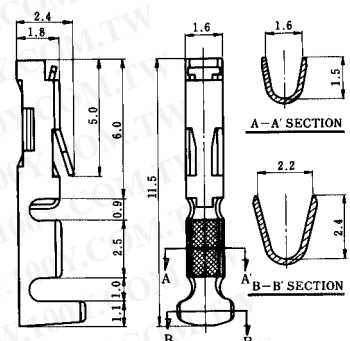
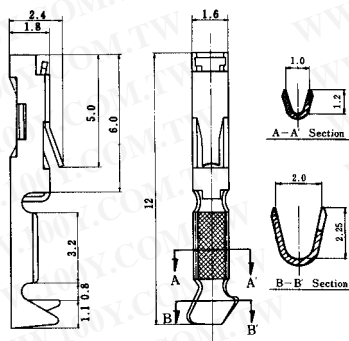
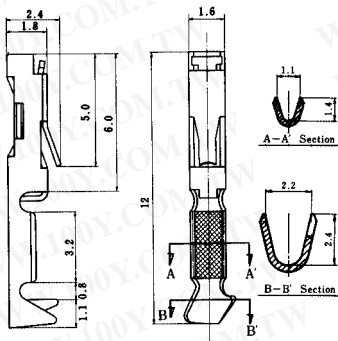

HIF3-2226SC	562-0079-8	gold plated contact in bag	RoHS YES
HIF3-2226SCA	562-0244-2	Selective gold plated contact in bag	
Applicable cable	AWG#22 to #26 UL 1007 Stranded wire		
Manual crimping tool	HIF3-T2226HC		

HIF3-2428SC	562-0124-0	gold plated contact in bag	RoHS YES
HIF3-2428SCA	562-0246-8	Selective gold plated contact in bag	
Applicable cable	AWG#24 to #28 UL 1007 Stranded wire		
Manual crimping tool	HIF3-TA2428HC		

HIF3-2022SC	562-0492-4	gold plated contact in bag	RoHS YES
Applicable cable	AWG#20 to #22 UL 1007 Stranded wire		
Manual crimping tool	HIF3-TA2022HC		

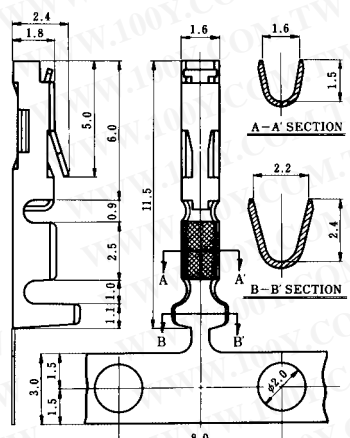
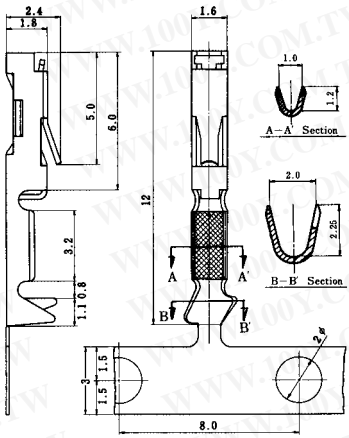
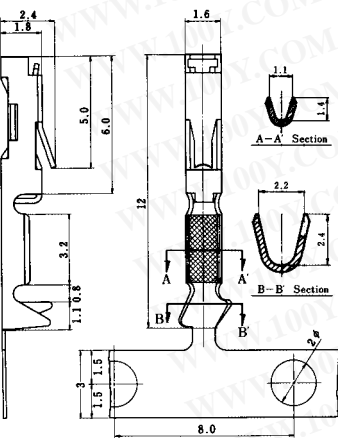

HIF3-2226SCF	562-0080-7	gold plated contact in reel	RoHS YES
HIF3-2226SCFA	562-0245-5	Selective gold plated contact in reel	
Applicable cable	AWG#22 to #26 UL 1007 Stranded wire		

HIF3-2428SCF	562-0125-3	gold plated contact in reel	RoHS YES
HIF3-2428SCFA	562-0247-0	Selective gold plated contact in reel	
Applicable cable	AWG#24 to #28 UL 1007 Stranded wire		

HIF3-2022SCF	562-0493-7	gold plated contact in reel	RoHS YES
Applicable cable	AWG#20 to #22 UL 1007 Stranded wire		

* HIF3-2226SCFA 562-0245-5 Selective gold plated contact in reel

* HIF3-2428SCFA 562-0247-0 Selective gold plated contact in reel

Note:* products have both side careers.

Type VA (Selective gold plated in reel)

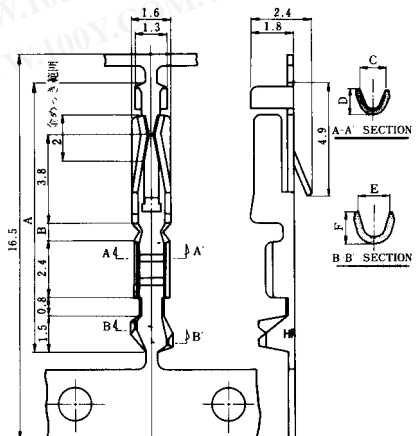
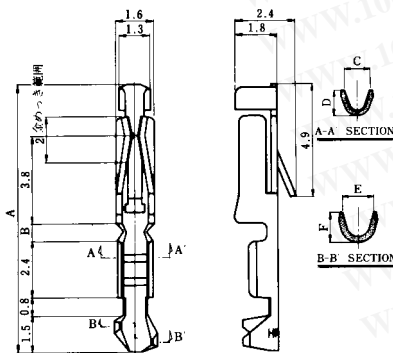

Part Number	CL No.	Applicable Cable	A	B	C	D	E	F	RoHS
HIF3-2226SCFC	613-0002-1	AWG#22 to #26 UL 1007 Stranded wire	11.5	0.8	1.8	1.8	2.3	2.6	
HIF3-2630SCFC	613-0001-9	AWG#26 to #30 UL 1007 Stranded wire	11.5	0.8	1.4	1.35	2.0	2.1	YES
HIF3A-3236SCFC	613-0005-0	AWG#32 to #36 UL 1007 Stranded wire	12.4	1.7	1.1	1.1	1.4	1.5	

Type VA (Selective gold plated contact in bag)

Part Number	CL No.	Applicable Cable	Manual Crimp Tool	A	B	C	D	E	F	RoHS
HIF3-2226SCC	613-0004-7	AWG#22 to #26 UL 1007 Stranded wire	HIF3-TB2226HC	11.5	0.8	1.8	1.8	2.3	2.6	YES
HIF3-2630SCC	613-0003-4	AWG#26 to #30 UL 1007 Stranded wire	HIF3-TB2630HC	11.5	0.8	1.4	1.35	2.0	2.1	

◆ Tools

● Crimping Tool



Part Number	CL No.
HIF3-T2226HC	550-0063-8

Manual Crimping Tool HIF3-T2226HC

● Automatic Crimping Tool (Type: CM-105)



Part Number	CL No.
CM-105	901-0005-4

● Contact Extraction Tools

How to use the extraction tool

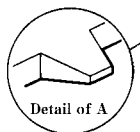
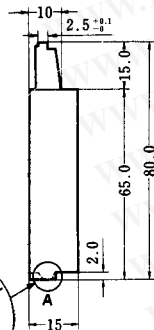

(1) How to extract contacts

As shown in Figure 1, where the extraction tool is inserted in the lance fixed slot on the insulated case, slightly pull the cable, and the contact can be removed.

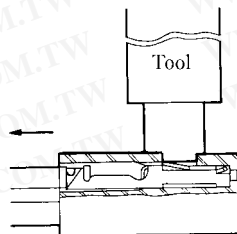

Figure 1

(2) How to adjust the lance (raise)

In order to re-insert the contact removed from the insulated case, raise the contact lance area using the tool A, and re-insert the contact, as shown in Figure 2.



Figure 2

Part Number	CL No.
HIF1-PO	550-0049-7

Type	Item	Part Number	CL No.	Applicable Contact	Applicable Cable
Manual	Manual crimping tool	HIF3-T2226HC	550-0063-8	HIF3-2226SC HIF3-2226SCA	AWG#22 to #26
		HIF3-TA2428HC	550-0100-2	HIF3-2428SC HIF3-2428SCA	AWG#24 to #28
		HIF3-TA2022HC	550-0124-0	HIF3-2022SC	AWG#20 to #22
		HIF3-TB2226HC	550-0154-1	HIF3-2226SCC	AWG#22 to #26
		HIF3-TB2630HC	550-0155-4	HIF3-2630SCC	AWG#26 to #30
Automatic	Automatic crimping tool unit	CM-105	901-0005-4	—————	—————
	Applicator	AP105-HIF3-22-28SCF <small>(Note1)</small>	901-4031-6	HIF3-2226SCF HIF3-2428SCF	AWG#22 to #26 AWG#24 to #28
		AP105-HIF3-22-28SCFA <small>(Note1)</small>	901-4030-3	HIF3-2226SCFA HIF3-2428SCFA	AWG#22 to #26 AWG#24 to #28
		AP105-HIF3-2022S	901-4027-9	HIF3-2022SCF	AWG#20 to #22
		AP105-HIF3-2226SCFC	901-4005-6	HIF3-2226SCFC	AWG#22 to #26
		AP105-HIF3-2630SCFC	901-4006-9	HIF3-2630SCFC	AWG#26 to #30
		AP105-HIF3-3236SCFC	901-4007-1	HIF3-3236SCFC	AWG#32 to #36
		Extraction tool	HIF1-PO	550-0049-7	—————

Note1: AP106-HIF3-22-28SCF and AP105-HIF3-22-28SCFA can be modified by changing a few parts.

◆ Socket Side (Crimping) Assembling Procedures

- (1) As shown in Figure 1, peel the applicable cable (AWG#20 to #26) jacket, and connect it using crimping jig HIF3-TA2022HC, HIF3-TA2226HC, or HIF3-TA2426HC. In this case, insert the cable so as to hit the contact cable stripper position as shown Figure 2.
- (2) After connection as shown Figure 2, check the contact direction, and insert the contact as shown Figures 3 and 4. Slightly pull the cable, and check whether the contact lance position is firmly fixed to the insulation case, as shown in the area (A).

Note1 : For handling procedures for special crimping tools, refer to the "Handling Instruction Manual".

Note2 : Wire strip length: Refer to crimp condition sheet.

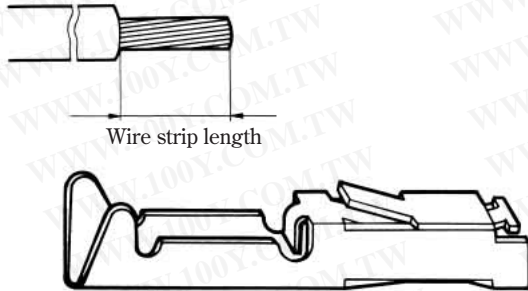

Figure 1

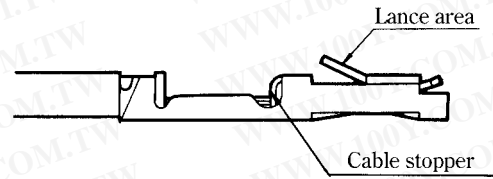

Figure 2

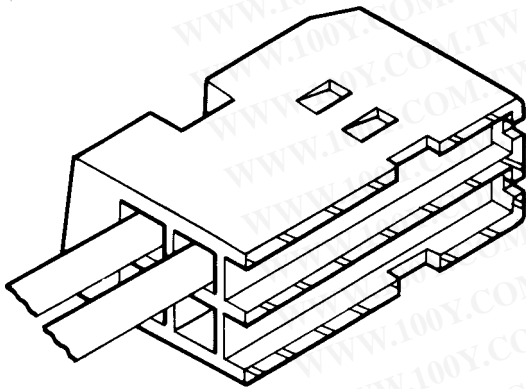

Figure 3

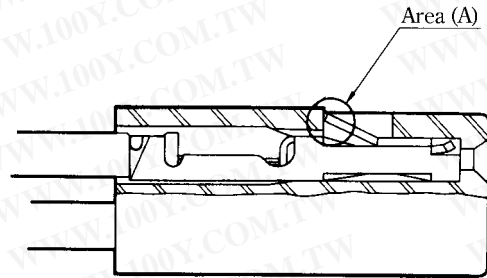
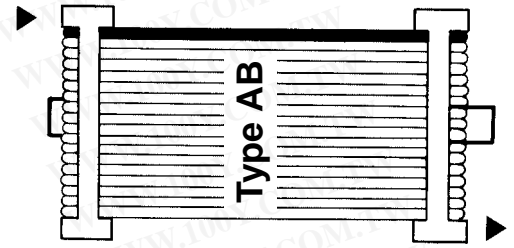
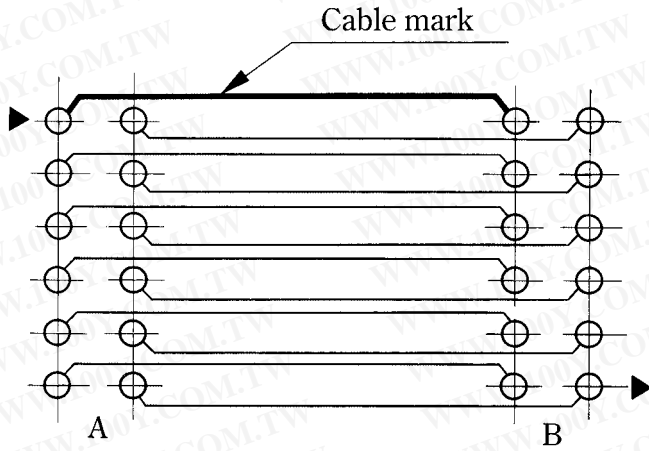

Figure 4

HIF3B Connection Circuit Diagram

Type AB



Type AD

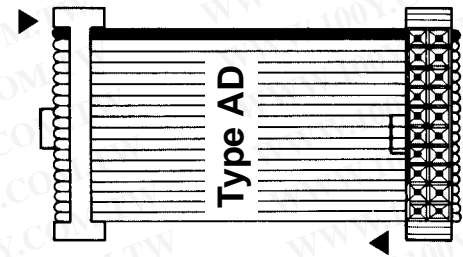
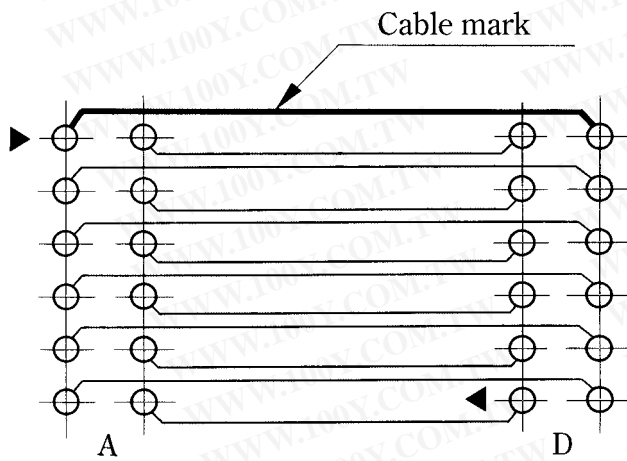

Type CD

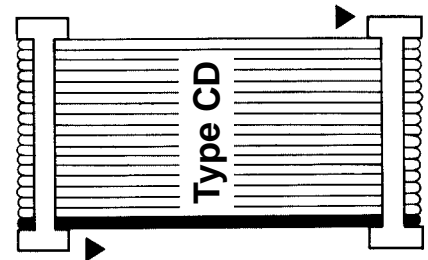
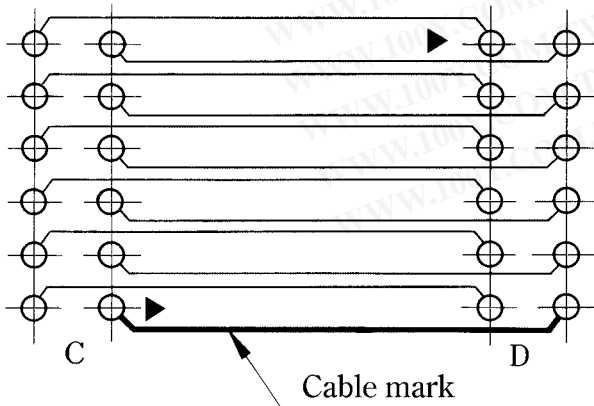

Type AC

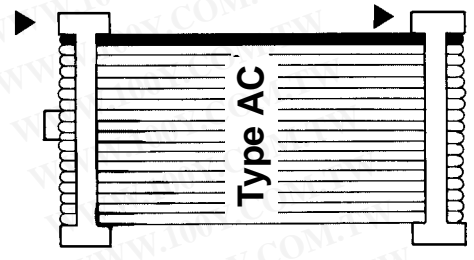
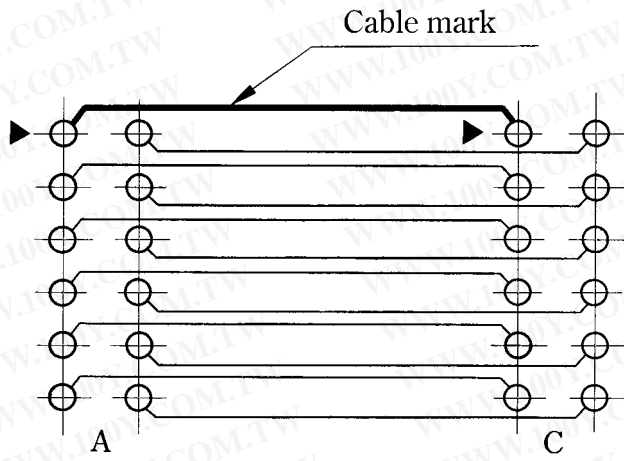

Type CC

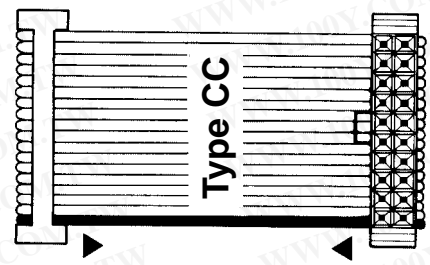
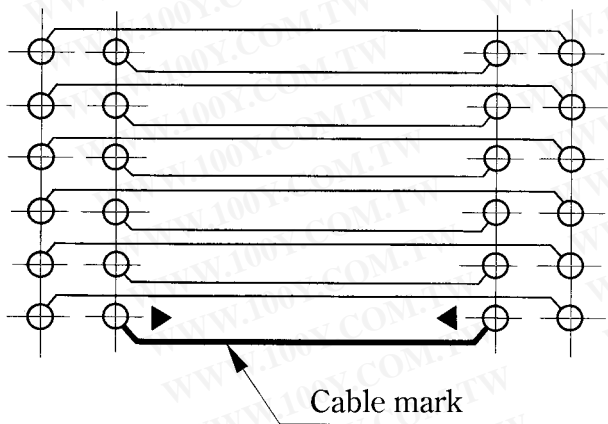

Type AA

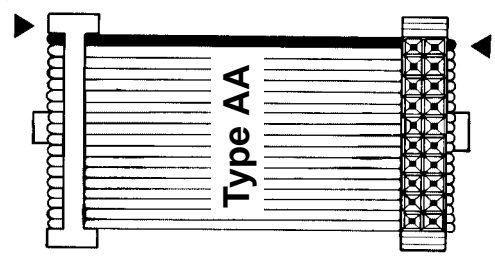
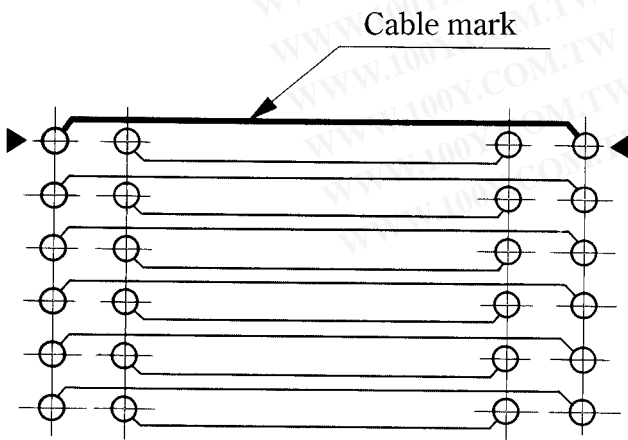

HIF2E R(S) A to HIF3B Connection Circuit Diagram

Type AA

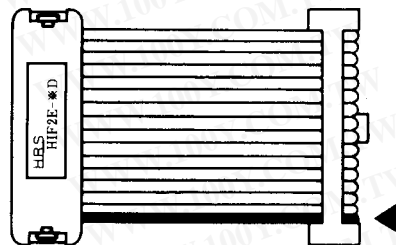
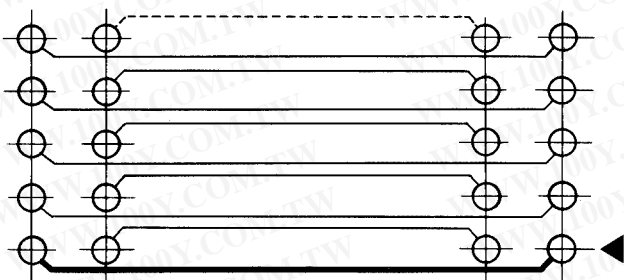

Type AC

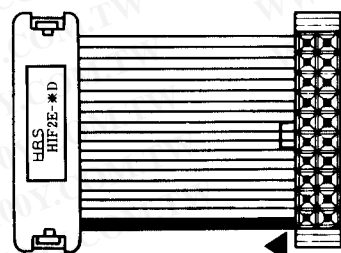
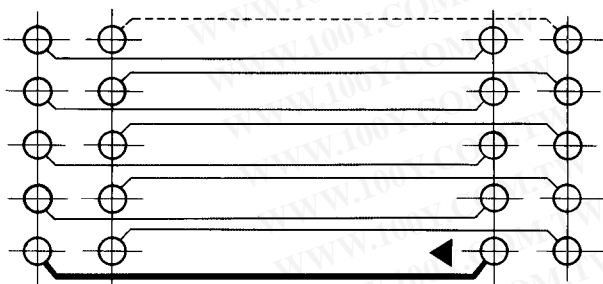

Type BA

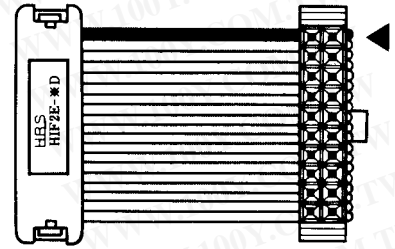
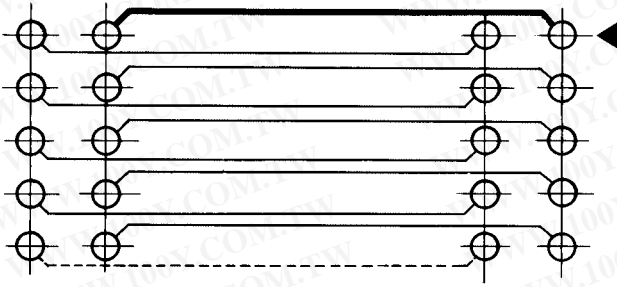

Type BC

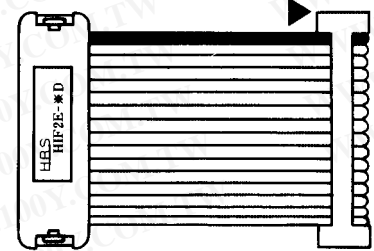
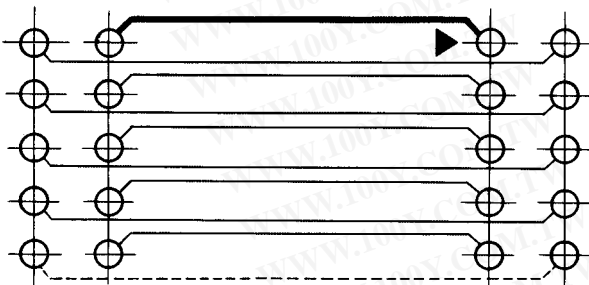

HIF2E R(S)B to HIF3 Connection Circuit Diagram

Type AA

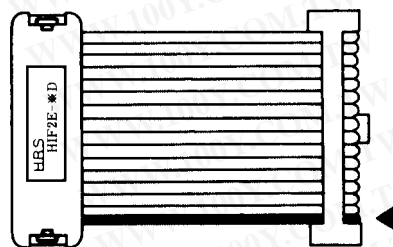
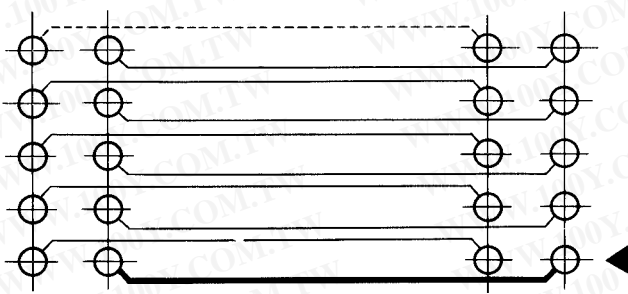

Type AC

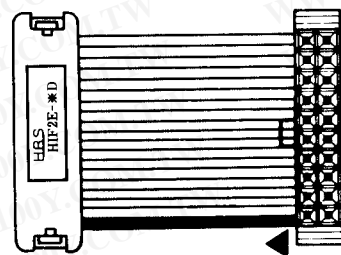
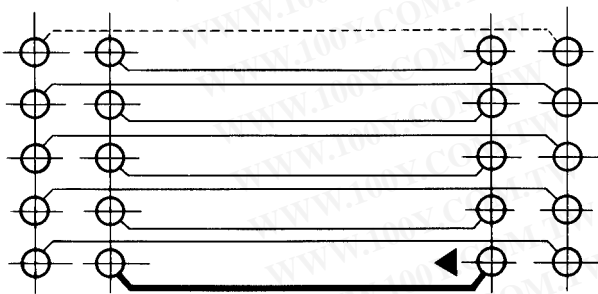

Type BA

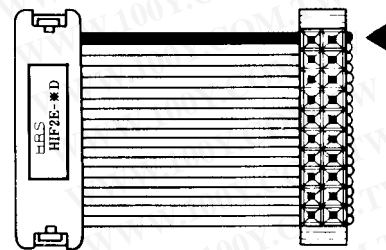
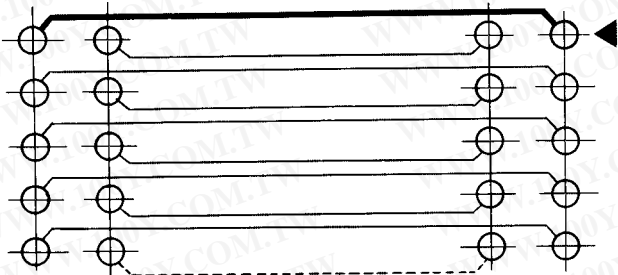

Type BC

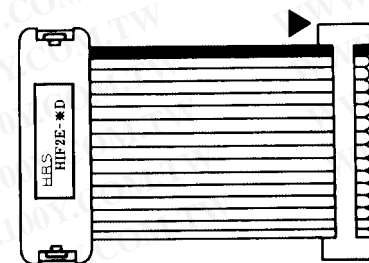
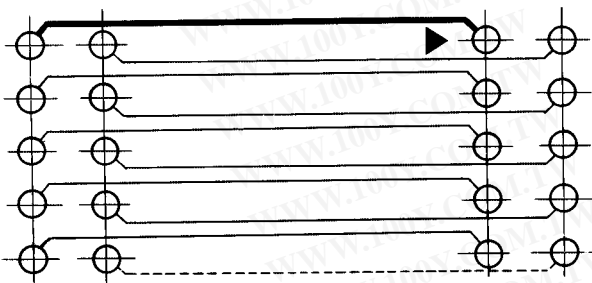

勝特力材料 886-3-5753170
勝特力电子(上海) 86-21-34970699
勝特力电子(深圳) 86-755-83298787
[Http://www.100y.com.tw](http://www.100y.com.tw)