

勝特力電材超市-龍山店 886-3-5773766
 勝特力電材超市-光復店 886-3-5729570
 勝特力电子(上海) 86-21-34970699
 勝特力电子(深圳) 86-755-83298787
<http://www.100y.com.tw>

N3300-9085

N Plug Solder Right Angle For RG405; 50Ω
3.6GHz VSWR 1.2

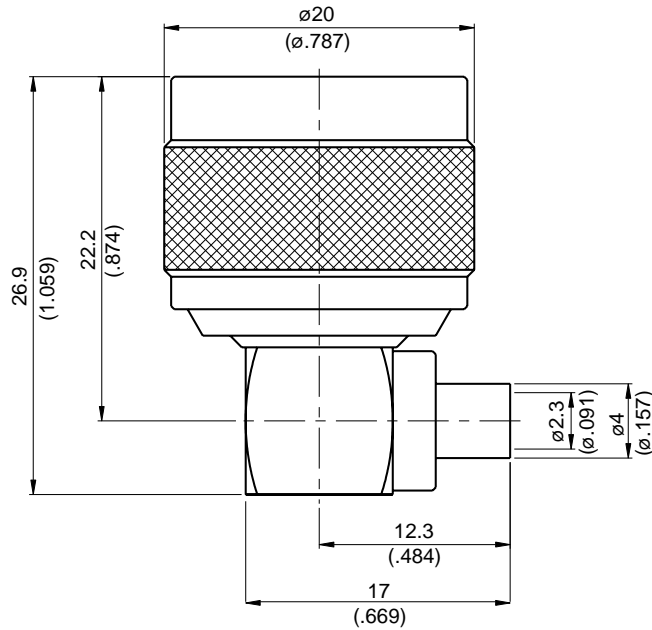



Parts	Material	Plating (Micro-inch)
Nut	Brass	Tin-Zinc-Copper-Alloy 100 Over Copper 50
Gasket	Silicon	
Center Pin	Brass	Gold 4 Over Nickel-Phosphorus Alloy 80 Over Copper 20
Insulator	Teflon	
Solder Body	Brass	Gold 4 Over Nickel-Phosphorus Alloy 80 Over Copper 20
Body	Brass	Tin-Zinc-Copper-Alloy 100 Over Copper 50
Coupling Nut	Brass	Tin-Zinc-Copper-Alloy 100 Over Copper 50

Weight: 30.26 g
 Suitable Cables: Semi-rigid.085

N	N3300-9085																		
<div data-bbox="167 344 569 394" style="border: 1px solid black; padding: 2px;">Interface</div> MIL-STD-348B																			
<div data-bbox="167 510 569 560" style="border: 1px solid black; padding: 2px;">Electrical Data</div> <table border="0" style="width: 100%;"> <tr> <td style="width: 50%;">Impedance</td> <td style="width: 50%;">50Ω</td> </tr> <tr> <td>Frequency range</td> <td>DC to 3.6GHz</td> </tr> <tr> <td>VSWR</td> <td>≦ 1.2 (DC to 3.6GHz)</td> </tr> <tr> <td>Insertion loss</td> <td>≦ 0.05 x √f(GHz)dB</td> </tr> <tr> <td>Insulation resistance</td> <td>≧ 5000MΩ</td> </tr> <tr> <td>Contact resistance inner conductor</td> <td>≦ 1.5mΩ</td> </tr> <tr> <td>Contact resistance outer conductor</td> <td>≦ 1mΩ</td> </tr> <tr> <td>Dielectric withstanding voltage (at sea level)</td> <td>2500 V rms</td> </tr> <tr> <td>Working voltage (at sea level)</td> <td>1000 V rms</td> </tr> </table>		Impedance	50Ω	Frequency range	DC to 3.6GHz	VSWR	≦ 1.2 (DC to 3.6GHz)	Insertion loss	≦ 0.05 x √f(GHz)dB	Insulation resistance	≧ 5000MΩ	Contact resistance inner conductor	≦ 1.5mΩ	Contact resistance outer conductor	≦ 1mΩ	Dielectric withstanding voltage (at sea level)	2500 V rms	Working voltage (at sea level)	1000 V rms
Impedance	50Ω																		
Frequency range	DC to 3.6GHz																		
VSWR	≦ 1.2 (DC to 3.6GHz)																		
Insertion loss	≦ 0.05 x √f(GHz)dB																		
Insulation resistance	≧ 5000MΩ																		
Contact resistance inner conductor	≦ 1.5mΩ																		
Contact resistance outer conductor	≦ 1mΩ																		
Dielectric withstanding voltage (at sea level)	2500 V rms																		
Working voltage (at sea level)	1000 V rms																		
<div data-bbox="167 1057 569 1106" style="border: 1px solid black; padding: 2px;">Mechanical Data</div> <table border="0" style="width: 100%;"> <tr> <td style="width: 50%;">Recommended coupling nut torque</td> <td style="width: 50%;">6 to 10 inch lbs</td> </tr> <tr> <td>Coupling proof torque</td> <td>15 inch lbs</td> </tr> <tr> <td>Coupling nut retention force</td> <td>≧ 101.2 lbs</td> </tr> <tr> <td>Contact captivation-axial</td> <td>≧ 6.3 lbs</td> </tr> <tr> <td>Durability (mating)</td> <td>≧ 500</td> </tr> </table>		Recommended coupling nut torque	6 to 10 inch lbs	Coupling proof torque	15 inch lbs	Coupling nut retention force	≧ 101.2 lbs	Contact captivation-axial	≧ 6.3 lbs	Durability (mating)	≧ 500								
Recommended coupling nut torque	6 to 10 inch lbs																		
Coupling proof torque	15 inch lbs																		
Coupling nut retention force	≧ 101.2 lbs																		
Contact captivation-axial	≧ 6.3 lbs																		
Durability (mating)	≧ 500																		
<div data-bbox="167 1411 569 1460" style="border: 1px solid black; padding: 2px;">Environmental Data</div> <table border="0" style="width: 100%;"> <tr> <td style="width: 50%;">Temperature range</td> <td style="width: 50%;">-65°C to +165°C</td> </tr> <tr> <td>Thermal shock</td> <td>MIL-STD-202, Method 107, Condition B</td> </tr> <tr> <td>Moisture resistance</td> <td>MIL-STD-202, Method 106</td> </tr> <tr> <td>Corrosion</td> <td>MIL-STD-202, Method 101, Condition B</td> </tr> <tr> <td>RoHS</td> <td>Compliant</td> </tr> </table>		Temperature range	-65°C to +165°C	Thermal shock	MIL-STD-202, Method 107, Condition B	Moisture resistance	MIL-STD-202, Method 106	Corrosion	MIL-STD-202, Method 101, Condition B	RoHS	Compliant								
Temperature range	-65°C to +165°C																		
Thermal shock	MIL-STD-202, Method 107, Condition B																		
Moisture resistance	MIL-STD-202, Method 106																		
Corrosion	MIL-STD-202, Method 101, Condition B																		
RoHS	Compliant																		
<div data-bbox="167 1765 569 1814" style="border: 1px solid black; padding: 2px;">Tooling</div> <table border="0" style="width: 100%;"> <tr> <td style="width: 50%;">Soldering fixture</td> <td style="width: 50%;">ST-008</td> </tr> <tr> <td>Insert for .085semi-rigid cable</td> <td>ST-009</td> </tr> <tr> <td>Locator tool</td> <td>ST-012</td> </tr> </table>		Soldering fixture	ST-008	Insert for .085semi-rigid cable	ST-009	Locator tool	ST-012												
Soldering fixture	ST-008																		
Insert for .085semi-rigid cable	ST-009																		
Locator tool	ST-012																		

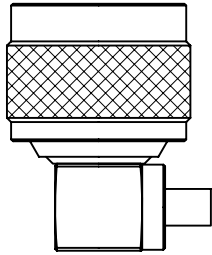
CABLE ASSEMBLY INSTRUCTION

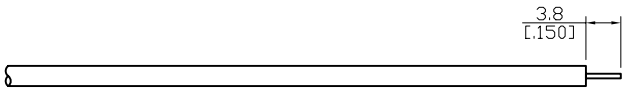
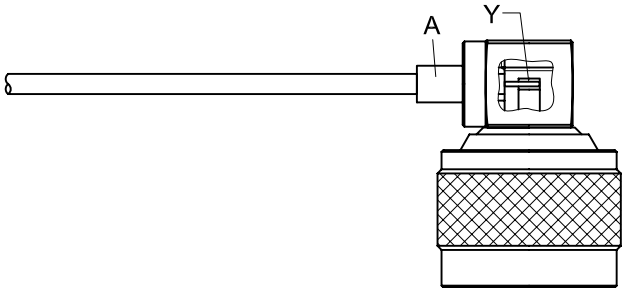
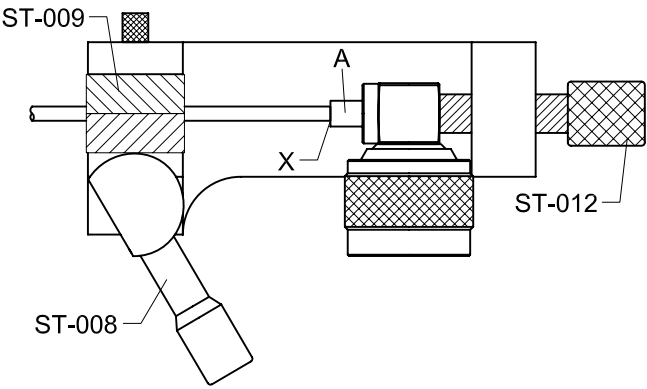
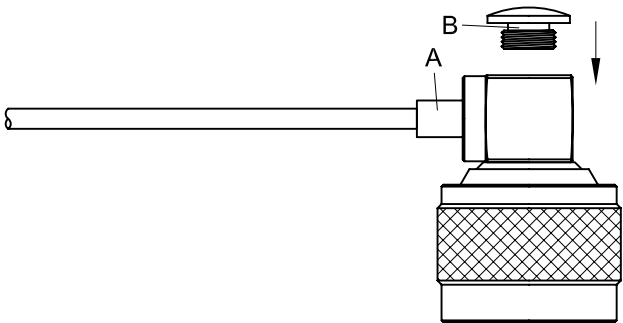
<p>N3300-9085</p>	<p>DATE</p>	<p>2014/04/29</p>	<p>REV</p>	<p>—</p>
<p>A</p>  <p>BODY</p>	<p>B</p>  <p>NUT</p>			
<p>DIAGRAM</p>	<p>ASSEMBLY INSTRUCTION</p>			
	<p>Step 1: STRIP AS SHOWN.</p>			
	<p>Step 2: SLIDE CENTER CONDUCTOR ON THE CONTACT PIN OF CONNECTOR " A " AND SOLDER IN " Y ".</p>			
	<p>Step 3: INSERT PREPARED CABLE INTO SOLDERING FIXTURE " ST-008 ". USE INSERT TOOL " ST-009 " AND LOCATOR TOOL " ST-012 " TO FIX THE CONNECTOR. SOLDER IN " X ".</p>			
	<p>STEP 4: FINALLY SCREW NUT " B " ON THE CONNECTOR BODY " A ".</p>			
<p>APPROVED</p>	<p>CHECKED</p>		<p>DRAWING</p> <p style="text-align: right;"><i>Albert</i></p>	

N3300-9085

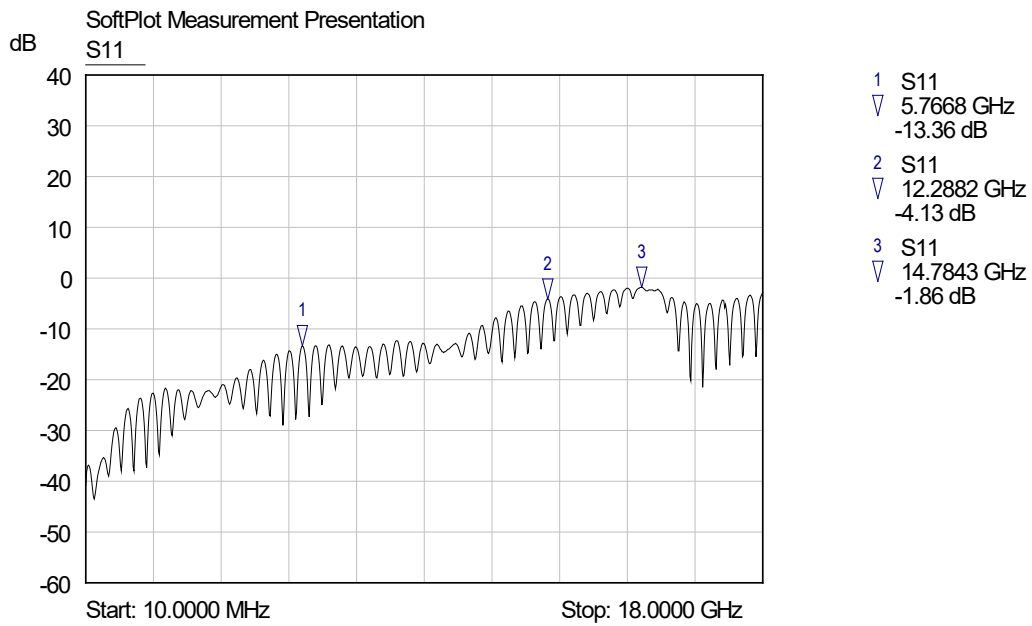

勝特力電材超市-龍山店 886-3-5773766
勝特力電材超市-光復店 886-3-5729570
勝特力電子(上海) 86-21-34970699
勝特力電子(深圳) 86-755-83298787
<http://www.100y.com.tw>