

MULTILAYER CERAMIC CAPACITORS

High Capacitance Series



1. DESCRIPTION

MLCC consists of a conducting material and electrodes. To manufacture a chip-type SMT and achieve miniaturization, high density and high efficiency, ceramic condensers are used.

WTC high capacitance MLCC offers low ESR and excellent frequency characteristics to be suited for coupling and decoupling applications in circuit. The high dielectric constant material X7R, X5R and Y5V are used for this series product.

2. FEATURES

- Small size with high capacitance.
- Capacitor with lead-free termination (pure Tin).

3. APPLICATIONS

- Digital circuit coupling or decoupling applications.
- For high frequency and high-density type power suppliers.
- For bypassing.

4. HOW TO ORDER

<u>1206</u>	<u>E</u>	<u>106</u>	<u>Z</u>	<u>100</u>	<u>C</u>	<u>I</u>
<u>Size</u>	<u>Dielectric</u>	<u>Capacitance</u>	<u>Tolerance</u>	<u>Rated voltage</u>	<u>Termination</u>	<u>Packaging</u>
Inch (mm) 0402 (1005) 0603 (1608) 0805 (2012) 1206 (3216) 1210 (3225) 1812 (4532)	B=X7R X=X5R F=Y5V	Two significant digits followed by no. of zeros. And R is in place of decimal point. eg.: 106=10x10 ⁶ =10μF	K=±10% M=±20% Z=-20/+80%	Two significant digits followed by no. of zeros. And R is in place of decimal point. 6R3=6.3 VDC 100=10 VDC 160=16 VDC 250=25 VDC 500=50 VDC	C=Cu/Ni/Sn	T=7" reeled G=13" reeled

勝特力材料 886-3-5753170
 勝特力电子(上海) 86-21-54151736
 勝特力电子(深圳) 86-755-83298787
[Http://www.100y.com.tw](http://www.100y.com.tw)

MULTILAYER CERAMIC CAPACITORS

High Capacitance Series



5. EXTERNAL DIMENSIONS

Size Inch (mm)	L (mm)	W (mm)	T (mm)/Symbol	Remark	M _B (mm)	
0402 (1005)	1.00±0.05	0.50±0.05	0.50±0.05	N	0.25 +0.05/-0.10	
0603 (1608)	1.60±0.10	0.80±0.10	0.80±0.07	S	0.40±0.15	
	1.60+0.15/-0.10	0.80+0.15/-0.10	0.80+0.15/-0.10	X		
0805 (2012)	2.00±0.15	1.25±0.10	0.80±0.10	B	0.50±0.20	
			1.25±0.10	D		#
	2.00±0.20	1.25±0.20	1.25±0.20	I		#
1206 (3216)	3.20±0.15	1.60±0.15	0.95±0.10	C	0.60±0.20	
			1.25±0.10	D		#
	3.20±0.20	1.60±0.20	1.60±0.20	G		#
			1.15±0.15	J		#
3.20+0.30/-0.10	1.60+0.30/-0.10	1.60+0.30/-0.10	P	#		
1210 (3225)	3.20±0.30	2.50±0.20	0.95±0.10	C	0.75±0.25	
			1.25±0.10	D		#
	3.20±0.40	2.50±0.30	1.60±0.20	G		#
			2.00±0.20	K		#
			2.50±0.30	M		#
1812 (4532)	4.50±0.40	3.20±0.30	1.25±0.10	D	0.75±0.25	
			2.00±0.20	K		#
			2.50±0.30	M		#

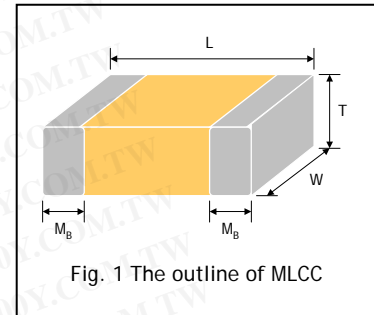

Fig. 1 The outline of MLCC

勝特力材料 886-3-5753170
 勝特力电子(上海) 86-21-54151736
 勝特力电子(深圳) 86-755-83298787
[Http://www.100y.com.tw](http://www.100y.com.tw)

Reflow soldering only is recommended.

6. GENERAL ELECTRICAL DATA

Dielectric	X7R	X5R	Y5V
Size	0402, 0603, 0805, 1206, 1210, 1812		
Capacitance range*	100nF to 4.7μF	100nF to 22μF	150nF to 100μF
Capacitance tolerance	K (±10%), M (±20%)		M (±20%), Z (-20/+80%)
Rated voltage (WVDC)	6.3V, 10V, 16V, 25V, 50V		
Tan δ*	Note 1		
Insulation resistance at U _r	R _x C≥500ΩxF		
Operating temperature	-55 to +125°C	-55 to +85°C	-25 to +85°C
Capacitance characteristic	±15%		+30/-80%
Termination	Ni/Sn (lead-free termination)		

* Measured at 1.0±0.2Vrms, 1.0kHz±10% for C≤10μF; 0.5±0.2Vrms, 120Hz±20% for C>10μF, 30~70% related humidity, 25°C ambient temperature for X7R, X5R and at 20°C for Y5V.

* Note 1

Rated vol.	D.F.	Exception of D.F.
≥50V	≤2.5%	≤3% 0603≥0.047μF; 0805≥0.18μF; 1206≥0.47μF
25V	≤3.5%	≤5% 0805≥1μF; 1210≥10μF
		≤7% 0603≥0.33μF
		≤10% 0603≥0.68μF; 0805≥4.7μF; 1206≥6.8μF
16V	≤3.5%	≤5% 0402≥0.033μF; 0603≥0.15μF; 0805≥0.68μF; 1206≥2.2μF; 1210≥4.7μF
		≤10% 0603≥0.68μF; 0805≥2.2μF; 1206≥6.8μF; 1210≥22μF
10V	≤5.0%	≤10% 0603≥1μF; 0805≥2.2μF; 1206≥6.8μF; 1210≥22μF
6.3V	≤10%	≤15.0% 0805≥10μF; 1210≥100μF

Y5V

Rated vol.	D.F.	Exception of D.F.
≥50V	≤5.0%	≤7% 0603≥0.1μF
35V	≤7%	---
25V	≤5.0%	≤7% 0402≥0.047; 0603≥0.1μF; 0805≥0.33μF; 1206≥1μF; 1210≥4.7μF
		≤9% 0402≥0.068μF; 0603≥0.47μF; 1206≥4.7μF
		≤7.0% 0402≥0.068μF; 0603≥0.68μF
16V (C<1.0μF)	≤7.0%	≤9% 0402≥0.068μF; 0603≥0.68μF
16V (C≥1.0μF)	≤9.0%	≤12.5% 0805≥4.7μF; 1206≥10μF; 1210≥22μF; 1812≥47μF
10V	≤12.5%	---
6.3V	≤20%	---

MULTILAYER CERAMIC CAPACITORS

High Capacitance Series



7. CAPACITANCE RANGE

7-1 X7R Dielectric

Dielectric		X7R																							
Size		0402		0603				0805			1206					1210				1812					
Rated Voltage (VDC)		6.3	10	10	16	25	50	10	16	25	6.3	10	16	25	50	10	16	25	50	10	16	25	50		
Capacitance	0.10μF (104)	N	N	S	S	S	X																		
	0.15μF (154)			S	S																				
	0.22μF (224)			S	S																				
	0.33μF (334)			X																					
	0.47μF (474)			X																					
	0.68μF (684)			X																					
	1.0μF (105)			X				D	D	D		J	J	J	P	D	D	D	D	D	D	D	D	D	K
	1.5μF (155)											J	J	J											
	2.2μF (225)											J	J	J	P										
	3.3μF (335)												P												
	4.7μF (475)											P	P	P											
	6.8μF (685)																								
10μF (106)																									

1. The letter in cell is expressed the symbol of product thickness.

7-2 X5R Dielectric

Dielectric		X5R													
Size		0402			0603			0805			1206			1210	
Rated Voltage (VDC)		6.3	10	16	6.3	10	16	6.3	10	16	6.3	10	16	10	16
Capacitance	0.027μF (273)			N											
	0.033μF (333)			N											
	0.039μF (393)			N											
	0.047μF (473)			N											
	0.056μF (563)		N												
	0.068μF (683)		N												
	0.082μF (823)		N												
	0.10μF (104)		N	N											
	0.15μF (154)														
	0.22μF (224)	N													
	0.33μF (334)					X	X								
	0.47μF (474)					X	X								
	0.68μF (684)					X	X								
	1.0μF (105)				X	X	X								
	1.5μF (155)				X			I	I			J	J	K	K
	2.2μF (225)				X			I	I	I		J	J	K	K
4.7μF (475)							I	I	I	P	P	P	K	K	
10μF (106)							I			P	P	P	K	K	
22μF (226)										P					

1. The letter in cell is expressed the symbol of product thickness.

勝特力材料 886-3-5753170
勝特力电子(上海) 86-21-54151736
勝特力电子(深圳) 86-755-83298787
[Http://www.100y.com.tw](http://www.100y.com.tw)

MULTILAYER CERAMIC CAPACITORS

High Capacitance Series



7-3 Y5V Dielectric

1. The letter in cell is expressed the symbol of product thickness.

		Y5V																								
Size		0402		0603			0805				1206					1210					1812					
Rated Voltage (VDC)		6.3	10	6.3	10	16	10	16	25	50	10	16	25	35	50	6.3	10	16	25	35	50	10	16	25	50	
Capacitance	0.15μF (154)		N																							
	0.22μF (224)	N	N																							
	0.33μF (334)	N	N																							
	0.47μF (474)	N	N																							
	0.68μF (684)	N																								
	1.0μF (105)	N			S	X	B	B	D	D	C	C	C		C	C	C	C		C		C	D	D	D	D
	1.5μF (155)				S		D	D			C	C	C			C	C	C				D	D	D	D	D
	2.2μF (225)				S		D	D			C	C	C			C	C	C				D	D	D	D	D
	3.3μF (335)			X			D	D			D	D	D			C	C	C				D	D	D	D	D
	4.7μF (475)			X			D	D			D	D	D	J		C	C	D				D	D	D	D	D
	6.8μF (685)						I				D	D				C	C	D				D	D	D	D	D
	10μF (106)						I				J	J				D	D	G	K			D	D	D		
22μF (226)										P						K	K									
47μF (476)																K						M				
100μF (107)															M											

8. PACKAGING STYLE AND QUANTITY

Size	Thickness (mm)/Symbol		Paper tape		Plastic tape	
			7" reel	13" reel	7" reel	13" reel
0402 (1005)	0.50±0.05	N	10k	50k	-	-
0603 (1608)	0.80±0.07	S	4k	15k	-	-
	0.80+0.15/-0.10	X	4k	15k	-	-
0805 (2012)	0.80±0.10	B	4k	15k	-	-
	1.25±0.10	D	-	-	3k	10k
	1.25±0.20	I	-	-	3k	10k
1206 (3216)	0.95±0.10	C	-	-	3k	10k
	1.15±0.15	J	-	-	3K	10K
	1.25±0.10	D	-	-	3k	10k
	1.60±0.20	G	-	-	2k	-
	1.60+0.30/-0.10	P	-	-	2k	-
1210 (3225)	0.95±0.10	C	-	-	3k	10k
	1.25±0.10	D	-	-	3k	10k
	1.60±0.20	G	-	-	2k	-
	2.00±0.20	K	-	-	1k	-
	2.50±0.30	M	-	-	1k	-
1812 (4532)	1.25±0.10	D	-	-	1k	-
	2.00±0.20	K	-	-	1k	-
	2.50±0.30	M	-	-	0.5k	-

Unit: pieces

勝特力材料 886-3-5753170
 勝特力电子(上海) 86-21-54151736
 勝特力电子(深圳) 86-755-83298787
[Http://www.100y.com.tw](http://www.100y.com.tw)

MULTILAYER CERAMIC CAPACITORS

High Capacitance Series



9. ELECTRICAL CHARACTERISTICS

Typical Impedance/ESR vs. Frequency

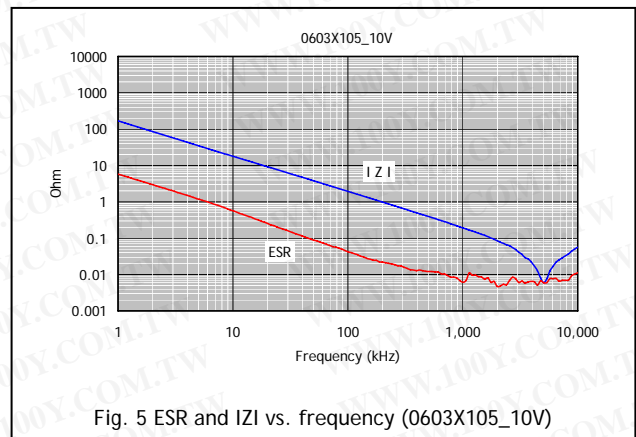
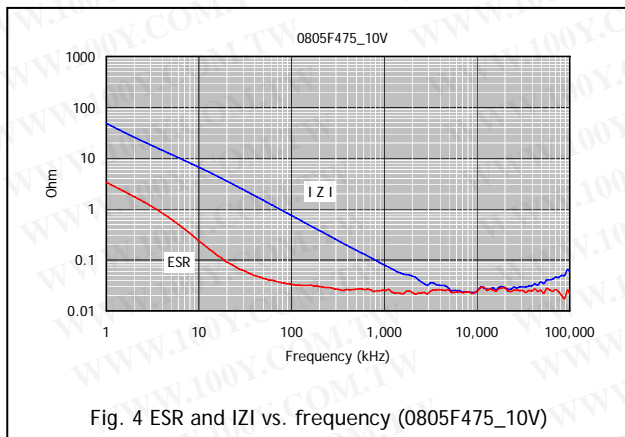
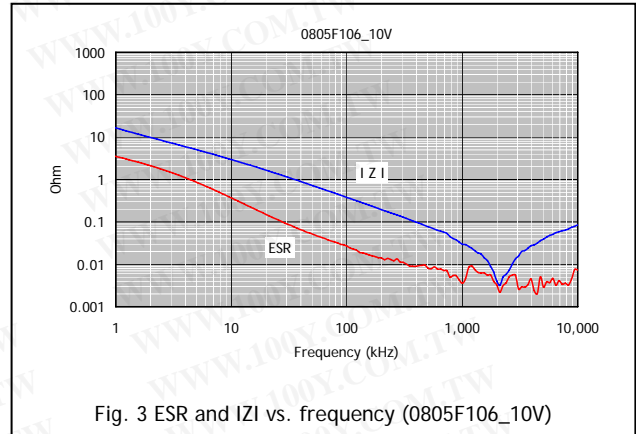
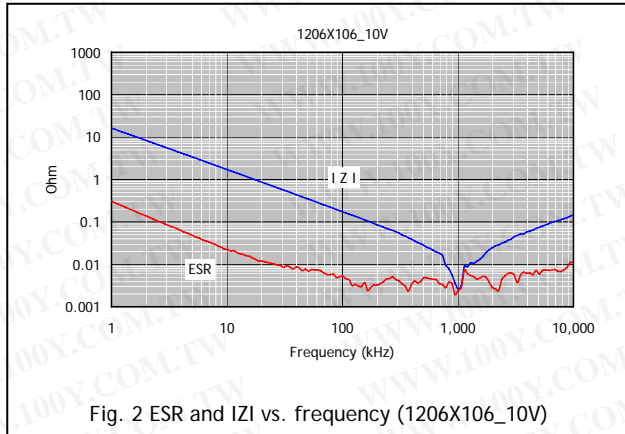

勝特力材料 886-3-5753170
勝特力电子(上海) 86-21-54151736
勝特力电子(深圳) 86-755-83298787
[Http://www.100y.com.tw](http://www.100y.com.tw)

MULTILAYER CERAMIC CAPACITORS

High Capacitance Series



10. RELIABILITY TEST CONDITIONS AND REQUIREMENTS

No.	Item	Test Condition	Requirements																																														
1.	Visual and Mechanical	--	* No remarkable defect. * Dimensions to conform to individual specification sheet.																																														
2.	Capacitance	Cap \leq 10 μ F, 1.0 \pm 0.2Vrms, 1kHz \pm 10%	* Shall not exceed the limits given in the detailed spec.																																														
3.	Q/ D.F. (Dissipation Factor)	Cap $>$ 10 μ F, 0.5 \pm 0.2Vrms, 120Hz \pm 20%	X7R, X5R: <table border="1"> <thead> <tr> <th>Rated vol.</th> <th>D.F.</th> <th>Exception of D.F.</th> </tr> </thead> <tbody> <tr> <td>\geq50V</td> <td>\leq2.5%</td> <td>\leq3% 0603\geq0.047μF; 0805\geq0.18μF; 1206\geq0.47μF</td> </tr> <tr> <td rowspan="3">25V</td> <td rowspan="3">\leq3.5%</td> <td>\leq5% 0805\geq1μF; 1210\geq10μF</td> </tr> <tr> <td>\leq7% 0603\geq0.33μF</td> </tr> <tr> <td>\leq10% 0603\geq0.68uF;0805\geq4.7uF;1206\geq6.8μF</td> </tr> <tr> <td rowspan="2">16V</td> <td rowspan="2">\leq3.5%</td> <td>\leq5% 0402\geq0.033μF; 0603\geq0.15μF; 0805\geq0.68μF; 1206\geq2.2μF; 1210\geq4.7uF</td> </tr> <tr> <td>\leq10% 0603\geq0.68uF;0805\geq2.2uF; 1206\geq6.8uF;1210\geq22μF</td> </tr> <tr> <td>10V</td> <td>\leq5.0%</td> <td>\leq10% 0603\geq1μF; 0805\geq2.2μF; 1206\geq6.8uF; 1210\geq22μF</td> </tr> <tr> <td>6.3V</td> <td>\leq10%</td> <td>\leq15.0% 0603\geq10uF;0805\geq10μF; 1210\geq100μF</td> </tr> </tbody> </table> Y5V: <table border="1"> <thead> <tr> <th>Rated vol.</th> <th>D.F.</th> <th>Exception of D.F.</th> </tr> </thead> <tbody> <tr> <td>\geq50V</td> <td>\leq5.0%</td> <td>\leq7% 0603\geq0.1μF</td> </tr> <tr> <td>35V</td> <td>\leq7%</td> <td>---</td> </tr> <tr> <td rowspan="2">25V</td> <td rowspan="2">\leq5.0%</td> <td>\leq7% 0603\geq0.1μF; 0805\geq0.33μF; 1206\geq1μF; 1210\geq4.7μF</td> </tr> <tr> <td>\leq9% 0402\geq0.068μF;0603\geq0.47uF; 1206\geq4.7μF</td> </tr> <tr> <td>16V (C$<$1.0μF)</td> <td>\leq7.0%</td> <td>\leq9% 0402\geq0.068μF;0603\geq0.68μF</td> </tr> <tr> <td>16V (C\geq1.0μF)</td> <td>\leq9.0%</td> <td>\leq12.5% 0805\geq4.7μF; 1206\geq10μF;1210\geq22μF; 1812\geq47μF</td> </tr> <tr> <td>10V</td> <td>\leq12.5%</td> <td>---</td> </tr> <tr> <td>6.3V</td> <td>\leq20%</td> <td>---</td> </tr> </tbody> </table>	Rated vol.	D.F.	Exception of D.F.	\geq 50V	\leq 2.5%	\leq 3% 0603 \geq 0.047 μ F; 0805 \geq 0.18 μ F; 1206 \geq 0.47 μ F	25V	\leq 3.5%	\leq 5% 0805 \geq 1 μ F; 1210 \geq 10 μ F	\leq 7% 0603 \geq 0.33 μ F	\leq 10% 0603 \geq 0.68uF;0805 \geq 4.7uF;1206 \geq 6.8 μ F	16V	\leq 3.5%	\leq 5% 0402 \geq 0.033 μ F; 0603 \geq 0.15 μ F; 0805 \geq 0.68 μ F; 1206 \geq 2.2 μ F; 1210 \geq 4.7uF	\leq 10% 0603 \geq 0.68uF;0805 \geq 2.2uF; 1206 \geq 6.8uF;1210 \geq 22 μ F	10V	\leq 5.0%	\leq 10% 0603 \geq 1 μ F; 0805 \geq 2.2 μ F; 1206 \geq 6.8uF; 1210 \geq 22 μ F	6.3V	\leq 10%	\leq 15.0% 0603 \geq 10uF;0805 \geq 10 μ F; 1210 \geq 100 μ F	Rated vol.	D.F.	Exception of D.F.	\geq 50V	\leq 5.0%	\leq 7% 0603 \geq 0.1 μ F	35V	\leq 7%	---	25V	\leq 5.0%	\leq 7% 0603 \geq 0.1 μ F; 0805 \geq 0.33 μ F; 1206 \geq 1 μ F; 1210 \geq 4.7 μ F	\leq 9% 0402 \geq 0.068 μ F;0603 \geq 0.47uF; 1206 \geq 4.7 μ F	16V (C $<$ 1.0 μ F)	\leq 7.0%	\leq 9% 0402 \geq 0.068 μ F;0603 \geq 0.68 μ F	16V (C \geq 1.0 μ F)	\leq 9.0%	\leq 12.5% 0805 \geq 4.7 μ F; 1206 \geq 10 μ F;1210 \geq 22 μ F; 1812 \geq 47 μ F	10V	\leq 12.5%	---	6.3V	\leq 20%	---
Rated vol.	D.F.	Exception of D.F.																																															
\geq 50V	\leq 2.5%	\leq 3% 0603 \geq 0.047 μ F; 0805 \geq 0.18 μ F; 1206 \geq 0.47 μ F																																															
25V	\leq 3.5%	\leq 5% 0805 \geq 1 μ F; 1210 \geq 10 μ F																																															
		\leq 7% 0603 \geq 0.33 μ F																																															
		\leq 10% 0603 \geq 0.68uF;0805 \geq 4.7uF;1206 \geq 6.8 μ F																																															
16V	\leq 3.5%	\leq 5% 0402 \geq 0.033 μ F; 0603 \geq 0.15 μ F; 0805 \geq 0.68 μ F; 1206 \geq 2.2 μ F; 1210 \geq 4.7uF																																															
		\leq 10% 0603 \geq 0.68uF;0805 \geq 2.2uF; 1206 \geq 6.8uF;1210 \geq 22 μ F																																															
10V	\leq 5.0%	\leq 10% 0603 \geq 1 μ F; 0805 \geq 2.2 μ F; 1206 \geq 6.8uF; 1210 \geq 22 μ F																																															
6.3V	\leq 10%	\leq 15.0% 0603 \geq 10uF;0805 \geq 10 μ F; 1210 \geq 100 μ F																																															
Rated vol.	D.F.	Exception of D.F.																																															
\geq 50V	\leq 5.0%	\leq 7% 0603 \geq 0.1 μ F																																															
35V	\leq 7%	---																																															
25V	\leq 5.0%	\leq 7% 0603 \geq 0.1 μ F; 0805 \geq 0.33 μ F; 1206 \geq 1 μ F; 1210 \geq 4.7 μ F																																															
		\leq 9% 0402 \geq 0.068 μ F;0603 \geq 0.47uF; 1206 \geq 4.7 μ F																																															
16V (C $<$ 1.0 μ F)	\leq 7.0%	\leq 9% 0402 \geq 0.068 μ F;0603 \geq 0.68 μ F																																															
16V (C \geq 1.0 μ F)	\leq 9.0%	\leq 12.5% 0805 \geq 4.7 μ F; 1206 \geq 10 μ F;1210 \geq 22 μ F; 1812 \geq 47 μ F																																															
10V	\leq 12.5%	---																																															
6.3V	\leq 20%	---																																															
4.	Dielectric Strength	To apply voltage (\leq 50V) 250%. Duration: 1 to 5 sec. Charge and discharge current less than 50mA.	* No evidence of damage or flash over during test.																																														
5.	Insulation Resistance	To apply rated voltage for max. 120 sec.	\geq 10G Ω or RxC \geq 500Q-F whichever is smaller. Class II (X5R, X6S, X7R, Y5V) <table border="1"> <thead> <tr> <th>Rated voltage</th> <th>Insulation Resistance</th> </tr> </thead> <tbody> <tr> <td>10V:0603$>$0.47μF;0805$>$2.2μF;1206$>$4.7μF</td> <td rowspan="2">\geq 100 Ω-F</td> </tr> <tr> <td>6.3V</td> </tr> </tbody> </table>	Rated voltage	Insulation Resistance	10V:0603 $>$ 0.47 μ F;0805 $>$ 2.2 μ F;1206 $>$ 4.7 μ F	\geq 100 Ω -F	6.3V																																									
Rated voltage	Insulation Resistance																																																
10V:0603 $>$ 0.47 μ F;0805 $>$ 2.2 μ F;1206 $>$ 4.7 μ F	\geq 100 Ω -F																																																
6.3V																																																	
6.	Temperature	With no electrical load.																																															
7.	Coefficient Adhesive Strength of Termination	<table border="1"> <thead> <tr> <th>T.C.</th> <th>Operating Temp</th> </tr> </thead> <tbody> <tr> <td>X7R</td> <td>-55-125°C at 25°C</td> </tr> <tr> <td>X5R</td> <td>-55-85°C at 25°C</td> </tr> <tr> <td>Y5V</td> <td>-25-85°C at 20°C</td> </tr> </tbody> </table> * Pressurizing force : 5N (\leq 0603) and 10N ($>$ 0603) * Test time: 10 \pm 1 sec.	T.C.	Operating Temp	X7R	-55-125°C at 25°C	X5R	-55-85°C at 25°C	Y5V	-25-85°C at 20°C	<table border="1"> <thead> <tr> <th>T.C.</th> <th>Capacitance Change</th> </tr> </thead> <tbody> <tr> <td>X7R</td> <td>Within \pm15%</td> </tr> <tr> <td>X5R</td> <td>Within \pm15%</td> </tr> <tr> <td>Y5V</td> <td>Within +30%/-80%</td> </tr> </tbody> </table> * No remarkable damage or removal of the terminations.	T.C.	Capacitance Change	X7R	Within \pm 15%	X5R	Within \pm 15%	Y5V	Within +30%/-80%																														
T.C.	Operating Temp																																																
X7R	-55-125°C at 25°C																																																
X5R	-55-85°C at 25°C																																																
Y5V	-25-85°C at 20°C																																																
T.C.	Capacitance Change																																																
X7R	Within \pm 15%																																																
X5R	Within \pm 15%																																																
Y5V	Within +30%/-80%																																																
8.	Vibration Resistance	* Vibration frequency: 10-55 Hz/min. * Total amplitude: 1.5mm * Test time: 6 hrs. (Two hrs each in three mutually perpendicular directions.)	* No remarkable damage. * Cap change and Q/D.F.: To meet initial spec.																																														
9.	Solderability	* Solder temperature: 235 \pm 5°C * Dipping time: 2 \pm 0.5 sec.	95% min. coverage of all metalized area.																																														

勝特力材料 886-3-5753170
勝特力电子(上海) 86-21-54151736
勝特力电子(深圳) 86-755-83298787
[Http://www.100y.com.tw](http://www.100y.com.tw)

MULTILAYER CERAMIC CAPACITORS

High Capacitance Series



No.	Item	Test Condition	Requirements																																																																		
10.	Bending Test	<p>The middle part of substrate shall be pressurized by means of the pressurizing rod at a rate of about 1 mm per second until the deflection becomes 1 mm and then the pressure shall be maintained for 5±1 sec.</p> <p>* Measurement to be made after keeping at room temp. for 24±2 hrs.</p>	<p>No remarkable damage.</p> <p>* Cap change : X7R, X5R: within ±12.5% Y5V: within ±30%</p> <p>(This capacitance change means the change of capacitance under specified flexure of substrate from the capacitance measured before the test.)</p>																																																																		
11.	Resistance to Soldering Heat	<p>Solder temperature: 270±5°C</p> <p>Dipping time: 10±1 sec</p> <p>Preheating: 120 to 150°C for 1 minute before immerse the capacitor in a eutectic solder.</p> <p>Before initial measurement (Class II only): Perform 150+0/-10°C for 1 hr and then set for 48±4 hrs at room temp.</p> <p>Measurement to be made after keeping at room temp. for 48±4 hrs.</p>	<p>No remarkable damage.</p> <p>* Cap change: X7R, X5R: within ±7.5% Y5V: within ±20%</p> <p>Q/D.F., I.R. and dielectric strength: To meet initial requirements. 25% max. leaching on each edge.</p>																																																																		
12.	Temperature Cycle	<p>Conduct the five cycles according to the temperatures and time.</p> <table border="1"> <thead> <tr> <th>Step</th> <th>Temp. (°C)</th> <th>Time (min.)</th> </tr> </thead> <tbody> <tr> <td>1</td> <td>Min. operating temp. +0/-3</td> <td>30±3</td> </tr> <tr> <td>2</td> <td>Room temp.</td> <td>2-3</td> </tr> <tr> <td>3</td> <td>Max. operating temp. +3/-0</td> <td>30±3</td> </tr> <tr> <td>4</td> <td>Room temp.</td> <td>2-3</td> </tr> </tbody> </table> <p>Before initial measurement (Class II only): Perform 150+0/-10°C for 1 hr and then set for 48±4 hrs at room temp.</p> <p>Measurement to be made after keeping at room temp. for 48±4 hrs.</p>	Step	Temp. (°C)	Time (min.)	1	Min. operating temp. +0/-3	30±3	2	Room temp.	2-3	3	Max. operating temp. +3/-0	30±3	4	Room temp.	2-3	<p>No remarkable damage.</p> <p>* Cap change : X7R, X5R: within ±7.5% Y5V: within ±20%</p> <p>Q/D.F., I.R. and dielectric strength: To meet initial requirements.</p>																																																			
Step	Temp. (°C)	Time (min.)																																																																			
1	Min. operating temp. +0/-3	30±3																																																																			
2	Room temp.	2-3																																																																			
3	Max. operating temp. +3/-0	30±3																																																																			
4	Room temp.	2-3																																																																			
13.	Humidity (Damp Heat) Steady State	<p>Test temp.: 40±2°C</p> <p>Humidity: 90-95% RH</p> <p>Test time: 500+24/-0hrs.</p> <p>Measurement to be made after keeping at room temp. for 48±4 hrs.</p>	<p>No remarkable damage.</p> <p>* Cap change: X7R, X5R: ≥10V, within ±12.5%; 6.3V, within ±25% Y5V: ≥10V, within ±30%; 6.3V, within +30/-40%</p> <p>Q/D.F. value: X7R, X5R:</p> <table border="1"> <thead> <tr> <th>Rated vol.</th> <th>D.F.</th> <th colspan="2">Exception of D.F.</th> </tr> </thead> <tbody> <tr> <td>≥50V</td> <td>≤3.0%</td> <td>≤6.0%</td> <td>0603≥0.047μF; 0805≥0.18μF; 1206≥0.47μF</td> </tr> <tr> <td>25V</td> <td>≤5.0%</td> <td>≤10.0%</td> <td>0805≥1μF; 1210≥10μF;</td> </tr> <tr> <td></td> <td></td> <td>≤14.0%</td> <td>0603≥0.33uF; 1206≥10μF</td> </tr> <tr> <td rowspan="2">16V</td> <td rowspan="2">≤5.0%</td> <td>≤10.0%</td> <td>0402≥0.033μF; 0603≥0.15μF; 0805≥0.68μF; 1206≥2.2μF; 1210≥4.7μF</td> </tr> <tr> <td>≤15.0%</td> <td>1210≥22μF</td> </tr> <tr> <td rowspan="2">10V</td> <td rowspan="2">≤7.5%</td> <td>≤15.0%</td> <td>0402≥0.056μF; 0603≥0.33μF; 0805≥2.2μF; 1206≥2.2μF; 1210≥22μF</td> </tr> <tr> <td></td> <td></td> </tr> <tr> <td>6.3V</td> <td>≤15.0%</td> <td>≤30.0%</td> <td>0603≥10μ; 0805≥10μF; 1210≥100μF</td> </tr> </tbody> </table> <p>Y5V:</p> <table border="1"> <thead> <tr> <th>Rated vol.</th> <th>D.F.</th> <th colspan="2">Exception of D.F.</th> </tr> </thead> <tbody> <tr> <td>≥50V</td> <td>≤7.5%</td> <td>---</td> <td>---</td> </tr> <tr> <td>35V</td> <td>≤10%</td> <td>---</td> <td>---</td> </tr> <tr> <td rowspan="2">25V</td> <td rowspan="2">≤7.5%</td> <td>≤10.0%</td> <td>0402≥0.047uF; 0603≥0.1μF; 0805≥0.33μF; 1206≥1μF; 1210≥4.7μF</td> </tr> <tr> <td>≤12.5%</td> <td>0402≥0.068μF; 0603≥0.47uF</td> </tr> <tr> <td>16V (C<1.0μF)</td> <td>≤10.0%</td> <td>≤12.5%</td> <td>0402≥0.068μF; 0603≥0.68μF</td> </tr> <tr> <td>16V (C≥1.0μF)</td> <td>≤12.5%</td> <td>≤20%</td> <td>0805≥4.7μF; 1206≥10μF; 1210≥22μF; 1812≥47μF</td> </tr> <tr> <td>10V</td> <td>≤15.0%</td> <td>---</td> <td>---</td> </tr> <tr> <td>6.3V</td> <td>≤30%</td> <td>---</td> <td>---</td> </tr> </tbody> </table> <p>* I.R.: ≥10V, ≥1GΩ or RxC≥50Ω-F whichever is smaller. 6.3V, RxC≥10Ω-F</p>	Rated vol.	D.F.	Exception of D.F.		≥50V	≤3.0%	≤6.0%	0603≥0.047μF; 0805≥0.18μF; 1206≥0.47μF	25V	≤5.0%	≤10.0%	0805≥1μF; 1210≥10μF;			≤14.0%	0603≥0.33uF; 1206≥10μF	16V	≤5.0%	≤10.0%	0402≥0.033μF; 0603≥0.15μF; 0805≥0.68μF; 1206≥2.2μF; 1210≥4.7μF	≤15.0%	1210≥22μF	10V	≤7.5%	≤15.0%	0402≥0.056μF; 0603≥0.33μF; 0805≥2.2μF; 1206≥2.2μF; 1210≥22μF			6.3V	≤15.0%	≤30.0%	0603≥10μ; 0805≥10μF; 1210≥100μF	Rated vol.	D.F.	Exception of D.F.		≥50V	≤7.5%	---	---	35V	≤10%	---	---	25V	≤7.5%	≤10.0%	0402≥0.047uF; 0603≥0.1μF; 0805≥0.33μF; 1206≥1μF; 1210≥4.7μF	≤12.5%	0402≥0.068μF; 0603≥0.47uF	16V (C<1.0μF)	≤10.0%	≤12.5%	0402≥0.068μF; 0603≥0.68μF	16V (C≥1.0μF)	≤12.5%	≤20%	0805≥4.7μF; 1206≥10μF; 1210≥22μF; 1812≥47μF	10V	≤15.0%	---	---	6.3V	≤30%	---	---
Rated vol.	D.F.	Exception of D.F.																																																																			
≥50V	≤3.0%	≤6.0%	0603≥0.047μF; 0805≥0.18μF; 1206≥0.47μF																																																																		
25V	≤5.0%	≤10.0%	0805≥1μF; 1210≥10μF;																																																																		
		≤14.0%	0603≥0.33uF; 1206≥10μF																																																																		
16V	≤5.0%	≤10.0%	0402≥0.033μF; 0603≥0.15μF; 0805≥0.68μF; 1206≥2.2μF; 1210≥4.7μF																																																																		
		≤15.0%	1210≥22μF																																																																		
10V	≤7.5%	≤15.0%	0402≥0.056μF; 0603≥0.33μF; 0805≥2.2μF; 1206≥2.2μF; 1210≥22μF																																																																		
6.3V	≤15.0%	≤30.0%	0603≥10μ; 0805≥10μF; 1210≥100μF																																																																		
Rated vol.	D.F.	Exception of D.F.																																																																			
≥50V	≤7.5%	---	---																																																																		
35V	≤10%	---	---																																																																		
25V	≤7.5%	≤10.0%	0402≥0.047uF; 0603≥0.1μF; 0805≥0.33μF; 1206≥1μF; 1210≥4.7μF																																																																		
		≤12.5%	0402≥0.068μF; 0603≥0.47uF																																																																		
16V (C<1.0μF)	≤10.0%	≤12.5%	0402≥0.068μF; 0603≥0.68μF																																																																		
16V (C≥1.0μF)	≤12.5%	≤20%	0805≥4.7μF; 1206≥10μF; 1210≥22μF; 1812≥47μF																																																																		
10V	≤15.0%	---	---																																																																		
6.3V	≤30%	---	---																																																																		

勝特力材料 886-3-5753170
勝特力电子(上海) 86-21-54151736
勝特力电子(深圳) 86-755-83298787
[Http://www.100y.com.tw](http://www.100y.com.tw)

MULTILAYER CERAMIC CAPACITORS

High Capacitance Series



No.	Item	Test Condition	Requirements																																																											
14.	Humidity (Damp Heat) Load	Test temp.: 40±2°C Humidity: 90-95%RH Test time: 500+24/-0 hrs. To apply voltage : rated voltage. Measurement to be made after keeping at room temp. for 48±4 hrs.	No remarkable damage. Cap change: X7R, X5R: ≥10V, within ±12.5%; 6.3V, within ±25% Y5V: ≥10V, within ±30%; 6.3V, within +30/-40% Q/D.F. value: X7R, X5R:																																																											
			<table border="1"> <thead> <tr> <th>Rated vol.</th> <th>D.F.</th> <th colspan="2">Exception of D.F.</th> </tr> </thead> <tbody> <tr> <td>≥50V</td> <td>≤3.0%</td> <td>≤6.0%</td> <td>0603≥0.047μF; 0805≥0.18μF; 1206≥0.47μF</td> </tr> <tr> <td rowspan="2">25V</td> <td rowspan="2">≤5.0%</td> <td>≤10.0%</td> <td>0805≥1μF; 1210≥10μF;</td> </tr> <tr> <td>≤14.0%</td> <td>0603≥0.33μF; 1206≥10μF</td> </tr> <tr> <td rowspan="2">16V</td> <td rowspan="2">≤5.0%</td> <td>≤10.0%</td> <td>0402≥0.033μF; 0603≥0.15μF; 0805≥0.68μF; 1206≥2.2μF; 1210≥4.7μF</td> </tr> <tr> <td>≤15.0%</td> <td>1210≥22μF</td> </tr> <tr> <td>10V</td> <td>≤7.5%</td> <td>≤15.0%</td> <td>0402≥0.056μF; 0603≥0.33μF; 0805≥2.2μF; 1206≥2.2μF; 1210≥22μF</td> </tr> <tr> <td>6.3V</td> <td>≤15.0%</td> <td>≤30.0%</td> <td>0603≥10μF; 0805≥10μF; 1210≥100μF</td> </tr> </tbody> </table> <p>Y5V:</p> <table border="1"> <thead> <tr> <th>Rated vol.</th> <th>D.F.</th> <th colspan="2">Exception of D.F.</th> </tr> </thead> <tbody> <tr> <td>≥50V</td> <td>≤7.5%</td> <td>---</td> <td>---</td> </tr> <tr> <td>35V</td> <td>≤10%</td> <td>---</td> <td>---</td> </tr> <tr> <td rowspan="2">25V</td> <td rowspan="2">≤7.5%</td> <td>≤10.0%</td> <td>0402≥0.047μF; 0603≥0.1μF; 0805≥0.33μF; 1206≥1μF; 1210≥4.7μF</td> </tr> <tr> <td>≤12.5%</td> <td>0402≥0.068μF; 0603≥0.47μF</td> </tr> <tr> <td>16V (C<1.0μF)</td> <td>≤10.0%</td> <td>≤12.5%</td> <td>0402≥0.068μF; 0603≥0.68μF</td> </tr> <tr> <td>16V (C≥1.0μF)</td> <td>≤12.5%</td> <td>≤20%</td> <td>0805≥4.7μF; 1206≥10μF; 1210≥22μF; 1812≥47μF</td> </tr> <tr> <td>10V</td> <td>≤15.0%</td> <td>---</td> <td>---</td> </tr> <tr> <td>6.3V</td> <td>≤30%</td> <td>---</td> <td>---</td> </tr> </tbody> </table> <p>I.R.: ≥10V, ≥500MΩ or RxC≥25Ω-F whichever is smaller. 6.3V, RxC≥5Ω-F</p>	Rated vol.	D.F.	Exception of D.F.		≥50V	≤3.0%	≤6.0%	0603≥0.047μF; 0805≥0.18μF; 1206≥0.47μF	25V	≤5.0%	≤10.0%	0805≥1μF; 1210≥10μF;	≤14.0%	0603≥0.33μF; 1206≥10μF	16V	≤5.0%	≤10.0%	0402≥0.033μF; 0603≥0.15μF; 0805≥0.68μF; 1206≥2.2μF; 1210≥4.7μF	≤15.0%	1210≥22μF	10V	≤7.5%	≤15.0%	0402≥0.056μF; 0603≥0.33μF; 0805≥2.2μF; 1206≥2.2μF; 1210≥22μF	6.3V	≤15.0%	≤30.0%	0603≥10μF; 0805≥10μF; 1210≥100μF	Rated vol.	D.F.	Exception of D.F.		≥50V	≤7.5%	---	---	35V	≤10%	---	---	25V	≤7.5%	≤10.0%	0402≥0.047μF; 0603≥0.1μF; 0805≥0.33μF; 1206≥1μF; 1210≥4.7μF	≤12.5%	0402≥0.068μF; 0603≥0.47μF	16V (C<1.0μF)	≤10.0%	≤12.5%	0402≥0.068μF; 0603≥0.68μF	16V (C≥1.0μF)	≤12.5%	≤20%	0805≥4.7μF; 1206≥10μF; 1210≥22μF; 1812≥47μF	10V	≤15.0%	---	---	6.3V
Rated vol.	D.F.	Exception of D.F.																																																												
≥50V	≤3.0%	≤6.0%	0603≥0.047μF; 0805≥0.18μF; 1206≥0.47μF																																																											
25V	≤5.0%	≤10.0%	0805≥1μF; 1210≥10μF;																																																											
		≤14.0%	0603≥0.33μF; 1206≥10μF																																																											
16V	≤5.0%	≤10.0%	0402≥0.033μF; 0603≥0.15μF; 0805≥0.68μF; 1206≥2.2μF; 1210≥4.7μF																																																											
		≤15.0%	1210≥22μF																																																											
10V	≤7.5%	≤15.0%	0402≥0.056μF; 0603≥0.33μF; 0805≥2.2μF; 1206≥2.2μF; 1210≥22μF																																																											
6.3V	≤15.0%	≤30.0%	0603≥10μF; 0805≥10μF; 1210≥100μF																																																											
Rated vol.	D.F.	Exception of D.F.																																																												
≥50V	≤7.5%	---	---																																																											
35V	≤10%	---	---																																																											
25V	≤7.5%	≤10.0%	0402≥0.047μF; 0603≥0.1μF; 0805≥0.33μF; 1206≥1μF; 1210≥4.7μF																																																											
		≤12.5%	0402≥0.068μF; 0603≥0.47μF																																																											
16V (C<1.0μF)	≤10.0%	≤12.5%	0402≥0.068μF; 0603≥0.68μF																																																											
16V (C≥1.0μF)	≤12.5%	≤20%	0805≥4.7μF; 1206≥10μF; 1210≥22μF; 1812≥47μF																																																											
10V	≤15.0%	---	---																																																											
6.3V	≤30%	---	---																																																											
15.	High Temperature Load (Endurance)	Test temp.: X7R: 125±3°C X5R, Y5V: 85±3°C To apply voltage: 200% of rated voltage. Test time: 1000+24/-0 hrs. Measurement to be made after keeping at room temp. for 48±4 hrs.	No remarkable damage. Cap change: X7R, X5R: ≥10V, within ±12.5%; 6.3V, within ±25% Y5V: ≥10V, within ±30%; 6.3V, within +30/-40% Q/D.F. value: X7R, X5R:																																																											
			<table border="1"> <thead> <tr> <th>Rated vol.</th> <th>D.F.</th> <th colspan="2">Exception of D.F.</th> </tr> </thead> <tbody> <tr> <td>≥50V</td> <td>≤3.0%</td> <td>≤6.0%</td> <td>0603≥0.047μF; 0805≥0.18μF; 1206≥0.47μF</td> </tr> <tr> <td rowspan="2">25V</td> <td rowspan="2">≤5.0%</td> <td>≤10.0%</td> <td>0805≥1μF; 1206≥10μF; 1210≥10μF;</td> </tr> <tr> <td>≤14.0%</td> <td>0603≥0.33μF</td> </tr> <tr> <td rowspan="2">16V</td> <td rowspan="2">≤5.0%</td> <td>≤10.0%</td> <td>0402≥0.033μF; 0603≥0.15μF; 0805≥0.68μF; 1206≥2.2μF; 1210≥4.7μF</td> </tr> <tr> <td>≤15.0%</td> <td>1210≥22μF</td> </tr> <tr> <td>10V</td> <td>≤7.5%</td> <td>≤15.0%</td> <td>0402≥0.056μF; 0603≥0.33μF; 0805≥2.2μF; 1206≥2.2μF; 1210≥22μF</td> </tr> <tr> <td>6.3V</td> <td>≤15.0%</td> <td>≤30.0%</td> <td>0603≥10μF; 0805≥10μF; 1210≥100μF</td> </tr> </tbody> </table> <p>Y5V:</p> <table border="1"> <thead> <tr> <th>Rated vol.</th> <th>D.F.</th> <th colspan="2">Exception of D.F.</th> </tr> </thead> <tbody> <tr> <td>≥50V</td> <td>≤7.5%</td> <td>---</td> <td>---</td> </tr> <tr> <td>35V</td> <td>≤10%</td> <td>---</td> <td>---</td> </tr> <tr> <td rowspan="2">25V</td> <td rowspan="2">≤7.5%</td> <td>≤10.0%</td> <td>0402≥0.047μF; 0603≥0.1μF; 0805≥0.33μF; 1206≥1μF; 1210≥4.7μF</td> </tr> <tr> <td>≤12.5%</td> <td>0402≥0.068μF; 0603≥0.47μF</td> </tr> <tr> <td>16V (C<1.0μF)</td> <td>≤10.0%</td> <td>≤12.5%</td> <td>0402≥0.068μF; 0603≥0.68μF</td> </tr> <tr> <td>16V (C≥1.0μF)</td> <td>≤12.5%</td> <td>≤20%</td> <td>0805≥4.7μF; 1206≥10μF; 1210≥22μF; 1812≥47μF</td> </tr> <tr> <td>10V</td> <td>≤15.0%</td> <td>---</td> <td>---</td> </tr> <tr> <td>6.3V</td> <td>≤30%</td> <td>---</td> <td>---</td> </tr> </tbody> </table> <p>I.R.: ≥10V, ≥1GΩ or RxC≥50Ω-F whichever is smaller. 6.3V, RxC≥10Ω-F</p>	Rated vol.	D.F.	Exception of D.F.		≥50V	≤3.0%	≤6.0%	0603≥0.047μF; 0805≥0.18μF; 1206≥0.47μF	25V	≤5.0%	≤10.0%	0805≥1μF; 1206≥10μF; 1210≥10μF;	≤14.0%	0603≥0.33μF	16V	≤5.0%	≤10.0%	0402≥0.033μF; 0603≥0.15μF; 0805≥0.68μF; 1206≥2.2μF; 1210≥4.7μF	≤15.0%	1210≥22μF	10V	≤7.5%	≤15.0%	0402≥0.056μF; 0603≥0.33μF; 0805≥2.2μF; 1206≥2.2μF; 1210≥22μF	6.3V	≤15.0%	≤30.0%	0603≥10μF; 0805≥10μF; 1210≥100μF	Rated vol.	D.F.	Exception of D.F.		≥50V	≤7.5%	---	---	35V	≤10%	---	---	25V	≤7.5%	≤10.0%	0402≥0.047μF; 0603≥0.1μF; 0805≥0.33μF; 1206≥1μF; 1210≥4.7μF	≤12.5%	0402≥0.068μF; 0603≥0.47μF	16V (C<1.0μF)	≤10.0%	≤12.5%	0402≥0.068μF; 0603≥0.68μF	16V (C≥1.0μF)	≤12.5%	≤20%	0805≥4.7μF; 1206≥10μF; 1210≥22μF; 1812≥47μF	10V	≤15.0%	---	---	6.3V
Rated vol.	D.F.	Exception of D.F.																																																												
≥50V	≤3.0%	≤6.0%	0603≥0.047μF; 0805≥0.18μF; 1206≥0.47μF																																																											
25V	≤5.0%	≤10.0%	0805≥1μF; 1206≥10μF; 1210≥10μF;																																																											
		≤14.0%	0603≥0.33μF																																																											
16V	≤5.0%	≤10.0%	0402≥0.033μF; 0603≥0.15μF; 0805≥0.68μF; 1206≥2.2μF; 1210≥4.7μF																																																											
		≤15.0%	1210≥22μF																																																											
10V	≤7.5%	≤15.0%	0402≥0.056μF; 0603≥0.33μF; 0805≥2.2μF; 1206≥2.2μF; 1210≥22μF																																																											
6.3V	≤15.0%	≤30.0%	0603≥10μF; 0805≥10μF; 1210≥100μF																																																											
Rated vol.	D.F.	Exception of D.F.																																																												
≥50V	≤7.5%	---	---																																																											
35V	≤10%	---	---																																																											
25V	≤7.5%	≤10.0%	0402≥0.047μF; 0603≥0.1μF; 0805≥0.33μF; 1206≥1μF; 1210≥4.7μF																																																											
		≤12.5%	0402≥0.068μF; 0603≥0.47μF																																																											
16V (C<1.0μF)	≤10.0%	≤12.5%	0402≥0.068μF; 0603≥0.68μF																																																											
16V (C≥1.0μF)	≤12.5%	≤20%	0805≥4.7μF; 1206≥10μF; 1210≥22μF; 1812≥47μF																																																											
10V	≤15.0%	---	---																																																											
6.3V	≤30%	---	---																																																											

勝特力材料 886-3-5753170
 勝特力电子(上海) 86-21-54151736
 勝特力电子(深圳) 86-755-83298787
[Http://www.100y.com.tw](http://www.100y.com.tw)

MULTILAYER CERAMIC CAPACITORS

High Capacitance Series



APPENDICES

■ Tape & reel dimensions

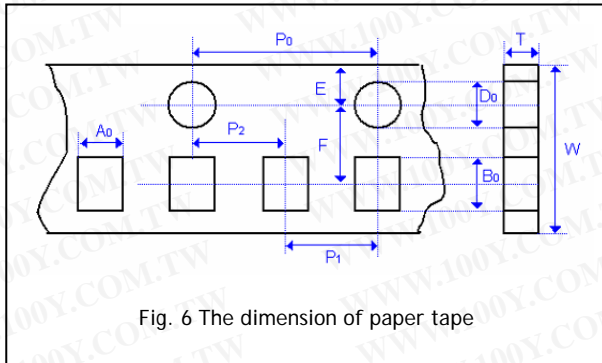

Fig. 6 The dimension of paper tape

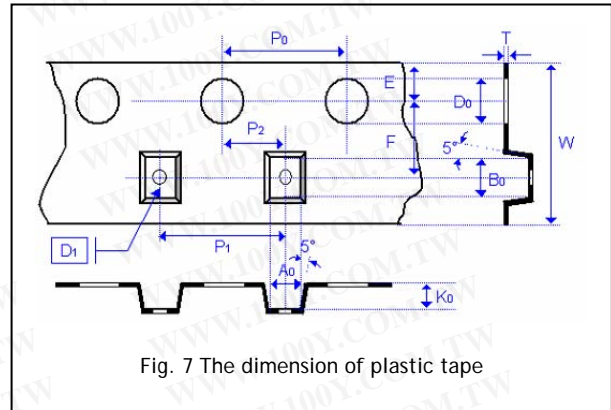

Fig. 7 The dimension of plastic tape

Size	0402	0603	0805			1206			1210			1812	
Thickness	N	S, X	A	B	C, D, I	B	C, J, D	G, P	C, D	G, K	M	D, K	M
A ₀	0.62±0.05	1.02±0.05	1.50±0.10	1.50±0.10	<1.57	2.00±0.10	<1.85	<1.95	<2.97	<2.97	<2.97	<3.81	<3.81
B ₀	1.12±0.05	1.82±0.05	2.30±0.10	2.30±0.10	<2.40	3.50±0.10	<3.46	<3.67	<3.73	<3.73	<3.73	<5.30	<5.30
T	0.60±0.05	0.95±0.05	0.75±0.05	0.95±0.05	0.23±0.05	0.95±0.05	0.23±0.05	0.23±0.05	0.23±0.05	0.23±0.05	0.23±0.05	0.25±0.05	0.25±0.05
K ₀	-	-	-	-	<2.50	-	<2.50	<2.50	<2.50	<2.50	<3.00	<2.50	<3.00
W	8.00±0.10	8.00±0.10	8.00±0.10	8.00±0.10	8.00±0.10	8.00±0.10	8.00±0.10	8.00±0.10	8.00±0.10	8.00±0.10	8.00±0.10	12.0±0.20	12.0±0.20
P ₀	4.00±0.10	4.00±0.10	4.00±0.10	4.00±0.10	4.00±0.10	4.00±0.10	4.00±0.10	4.00±0.10	4.00±0.10	4.00±0.10	4.00±0.10	4.00±0.10	4.00±0.10
10xP ₀	40.0±0.10	40.0±0.10	40.0±0.10	40.0±0.10	40.0±0.10	40.0±0.10	40.0±0.10	40.0±0.10	40.0±0.10	40.0±0.10	40.0±0.10	40.0±0.10	40.0±0.10
P ₁	2.00±0.05	4.00±0.10	4.00±0.10	4.00±0.10	4.00±0.10	4.00±0.10	4.00±0.10	4.00±0.10	4.00±0.10	4.00±0.10	4.00±0.10	8.00±0.10	8.00±0.10
P ₂	2.00±0.05	2.00±0.05	2.00±0.05	2.00±0.05	2.00±0.05	2.00±0.05	2.00±0.05	2.00±0.05	2.00±0.05	2.00±0.05	2.00±0.05	2.00±0.05	2.00±0.05
D ₀	1.55±0.05	1.55±0.05	1.55±0.05	1.55±0.05	1.50±0.05	1.50±0.05	1.50±0.05	1.50±0.05	1.50±0.05	1.50±0.05	1.50±0.05	1.50±0.05	1.50±0.05
D ₁	-	-	-	-	1.00±0.10	-	1.00±0.10	1.00±0.10	1.00±0.10	1.00±0.10	1.00±0.10	1.50±0.10	1.50±0.10
E	1.75±0.05	1.75±0.05	1.75±0.05	1.75±0.05	1.75±0.10	1.75±0.10	1.75±0.10	1.75±0.10	1.75±0.10	1.75±0.10	1.75±0.10	1.75±0.10	1.75±0.10
F	3.50±0.05	3.50±0.05	3.50±0.05	3.50±0.05	3.50±0.05	3.50±0.05	3.50±0.05	3.50±0.05	3.50±0.05	3.50±0.05	3.50±0.05	5.50±0.05	5.50±0.05

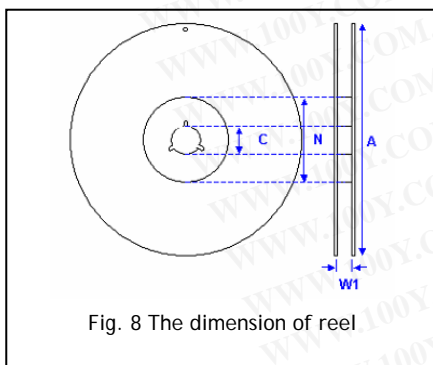

Fig. 8 The dimension of reel

Size	0402, 0603, 0805, 1206, 1210			1812
Reel size	7"	10"	13"	7"
C	13.0+0.5/-0.2	13.0+0.5/-0.2	13.0+0.5/-0.2	13.0+0.5/-0.2
W ₁	8.4+1.5/-0	8.4+1.5/-0	8.4+1.5/-0	12.4+2.0/-0
A	178.0±0.10	250.0±1.0	330.0±1.0	178.0±0.10
N	60.5±1.0	100.0±1.0	100±1.0	60.5±1.0

勝特力材料 886-3-5753170
勝特力电子(上海) 86-21-54151736
勝特力电子(深圳) 86-755-83298787
[Http://www.100y.com.tw](http://www.100y.com.tw)

MULTILAYER CERAMIC CAPACITORS

High Capacitance Series



Description of customer label

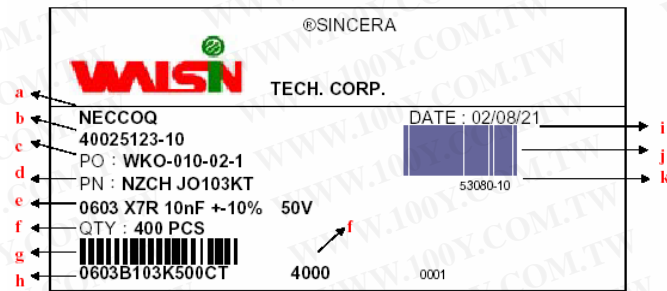

- a. Customer name
- b. WTC order series and item number
- c. Customer P/O
- d. Customer P/N
- e. Description of product
- f. Quantity
- g. Bar code including quantity & WTC P/N or customer
- h. WTC P/N
- i. Shipping date
- j. Order bar code including series and item numbers
- k. Serial number of label

Constructions

No.	Name	X7R, X5R, Y5V	
①	Ceramic material	BaTiO ₃ based	
②	Inner electrode	Ni	
③	Termination	Inner layer	Cu
④		Middle layer	Ni
⑤		Outer layer	Sn (Matt)

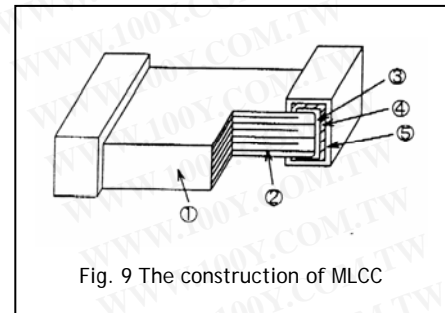

Storage and handling conditions

- (1) To store products at 5 to 40°C ambient temperature and 20 to 70% related humidity conditions.
- (2) The product is recommended to be used within one year after shipment. Check solderability in case of shelf life extension is needed.

Cautions:

- a. Don't store products in a corrosive environment such as sulfide, chloride gas, or acid. It may cause oxidation of electrode, which easily be resulted in poor soldering.
- b. To store products on the shelf and avoid exposure to moisture.
- c. Don't expose products to excessive shock, vibration, direct sunlight and so on.

勝特力材料 886-3-5753170
 勝特力电子(上海) 86-21-54151736
 勝特力电子(深圳) 86-755-83298787
[Http://www.100y.com.tw](http://www.100y.com.tw)

MULTILAYER CERAMIC CAPACITORS

High Capacitance Series



Recommended soldering conditions

The lead-free termination MLCCs are not only to be used on SMT against lead-free solder paste, but also suitable against lead-containing solder paste. If the optimized solder joint is requested, increasing soldering time, temperature and concentration of N_2 within oven are recommended.

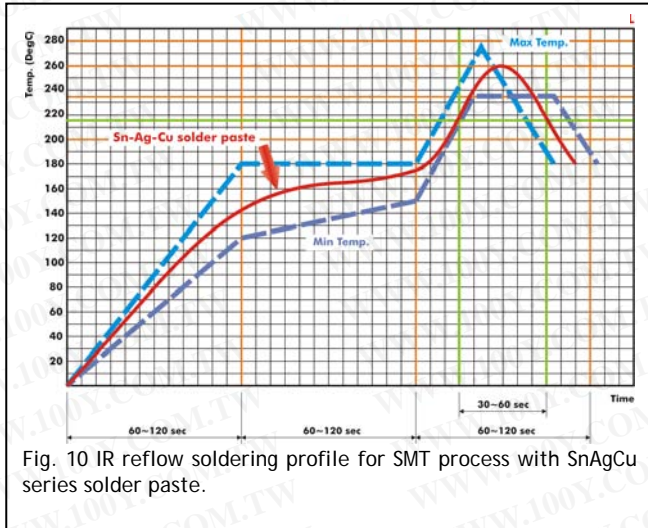

Fig. 10 IR reflow soldering profile for SMT process with SnAgCu series solder paste.

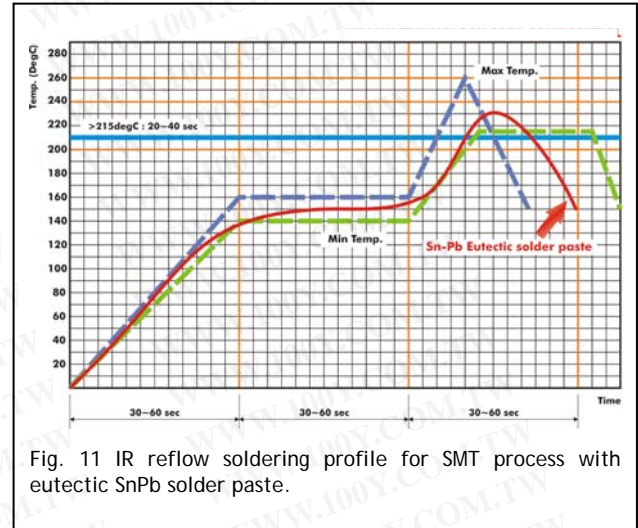

Fig. 11 IR reflow soldering profile for SMT process with eutectic SnPb solder paste.

勝特力材料 886-3-5753170
勝特力电子(上海) 86-21-54151736
勝特力电子(深圳) 86-755-83298787
[Http://www.100y.com.tw](http://www.100y.com.tw)