

Aluminum Capacitors Axial Capacitor Style

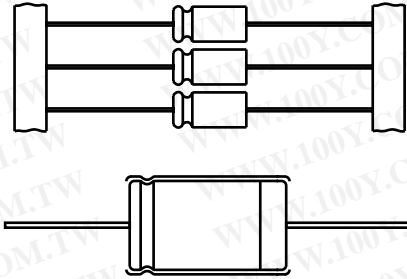

Component outlines

FEATURES

- Polarized aluminum electrolytic capacitors
- High ripple current capability
- Very long lifetime
- Charge/discharge proof
- Temperature range 105 °C
- Compliant to RoHS directive 2002/95/EC



RoHS
COMPLIANT

APPLICATIONS

- Industrial and automotive electronics, audio/video, telecommunication systems, power supply units
- Coupling, smoothing, filtering, buffering and timing

QUICK REFERENCE DATA

DESCRIPTION	UNIT	LOW VOLTAGE	HIGH VOLTAGE
Nominal case size (Ø D x L)	mm	6.5 x 18 to 10 x 25	6.5 x 18 to 10 x 25
Rated capacitance range C _R	µF	4.7 to 470	1.0 to 22
Capacitance tolerance	%	- 10/+ 50	
Rated voltage range	V	16 to 100	160 to 250
Category temperature range	°C	- 40 to + 105	
Endurance test at upper category temp.	h	2000	
Useful life at 105 °C and I _R applied	h	3000	3000
Useful life at 85 °C and I _R applied	h	11 000	11 000
Useful life at 40 °C and I _R applied	h	330 000	330 000
Shelf life (0 V, 105 °C)	h	100	
Failure rate	10 ⁻⁹ /h	≤ 14	≤ 14
Based on sectional specification		IEC 60384-4, EN 130300	
Based on detailed specifications		CECC 30301-003, CECC 30301-801 DIN 45910 Part 123, without quality assessment	
Climatic category IEC 60068 DIN 40040		40/105/56 GMF	

SELECTION CHART FOR C_R, U_R AND RELEVANT NOMINAL CASE SIZES (Ø D x L in mm)

C _R (µF)	U _R (V)						
	16	25	40	63	100	160	250
1.0	→	→	→	→	→	→	→
2.2	→	→	→	→	→	6.5 x 18	8 x 18
4.7	→	→	→	→	→	→	→
47	6.5 x 18	8 x 18	8 x 18	10 x 18	10 x 25	12 x 30	-
100	8 x 18	10 x 18	10 x 18	12 x 25	12 x 30	-	-
220	10 x 18	10 x 25	12 x 25	12 x 30	-	-	-
470	10 x 25	-	-	-	-	-	-

DIMENSIONS in millimeters **AND AVAILABLE FORMS**

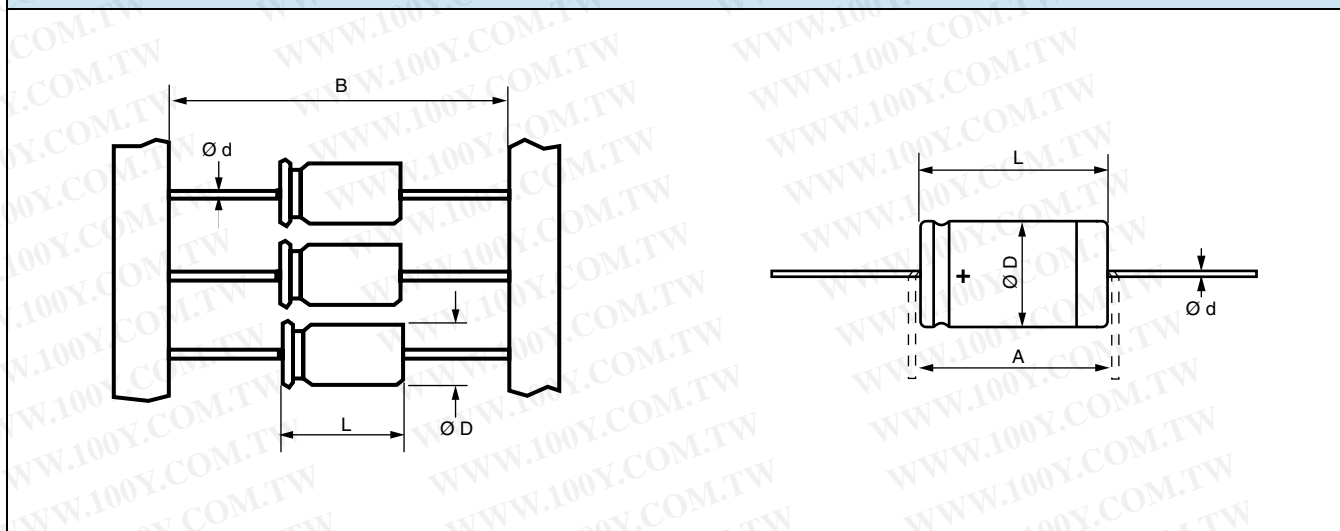

AXIAL: DIMENSIONS in millimeters, **MASS, PACKAGING AND ORDERING CODE**

CASE SIZE $\varnothing D \times L$	LEAD $\varnothing d$	$\varnothing D_{max.}$	$L_{max.}$	$A_{min.}$	B	WEIGHT APPROX. g	PACKAGING, ENDING OF ORDERING CODE, QUANTITIES			
							TAPED ON REEL		TAPED AMMO	
							code	pieces	code	pieces
6.5 x 18	0.8	6.9	18.5	25	73.0 ± 1.6	1.3	..A0W	1000	..B0W	1000
8 x 18	0.8	8.5	18.5	25	73.0 ± 1.6	1.7	..A0W	500	..B0W	500
10 x 18	0.8	10.5	18.5	25	73.0 ± 1.6	2.5	..A0W	500	..B0W	500
10 x 25	0.8	10.5	25.5	30	73.0 ± 1.6	3.3	..A0W	500	..B0W	500

Note
Axial style capacitors are insulated.

ELECTRICAL DATA	
SYMBOL	DESCRIPTION
C_R	rated capacitance at 100 Hz
U_R	rated voltage
$\tan \delta$	max. dissipation factor at 100 Hz
R_{ESR}	equivalent series resistance at 100 Hz, (calculated from $\tan \delta_{max.}$ and C_R)
Z	max. impedance at 10 kHz
I_R	rated alternating current (rms) at 100 Hz and upper category temperature
T_a	ambient temperature
T_{uc}	upper category temperature
RH	relative humidity
P	ambient pressure

Note
Unless otherwise specified, all electrical values apply at $T_a = 20 \text{ }^\circ\text{C}$, $P = 80 \text{ kPa}$ to 106 kPa , $RH = 45 \%$ to 75% .

ORDERING EXAMPLE

The following table gives the ordering number.

The 16th place of ordering code refers to packaging for axial lead capacitors:

MALAEBC00FL210J...	EBC 1000 μF 63 V 8 x 18
MALAEBC00FL210JA0W	A = taped on reel
MALAEBC00FL210JB0W	B = taped ammo

Please see table "Axial Styles" for available versions.

 Aluminum Capacitors
 Axial Capacitor Style

Vishay Roederstein

ELECTRICAL DATA AND ORDERING INFORMATION							
U_R (V)	C_R 100 Hz (μ F)	NOMINAL CASE SIZE \varnothing D x L (mm)	$\tan \delta$ 100 Hz max.	R_{ESR} 100 Hz (Ω)	Z 10 kHz max. (Ω)	I_R 100 Hz T_{UC} (A)	CATALOG NUMBER MALA...
16	47	6.5 x 18	0.14	4.7	2.6	0.095	EBC00DL247DB0W
	100	8 x 18	0.14	2.2	1.2	0.15	EBC00FL310DB0W
	220	10 x 18	0.14	1.0	0.55	0.25	EBC00GL322DB0W
	470	10 x 25	0.14	0.47	0.26	0.45	EBC00GD347DB0W
25	22	6.5 x 18	0.11	8.0	4.1	0.060	EBC00DL222EB0W
	47	8 x 18	0.11	3.7	1.9	0.11	EBC00FL247EB0W
	100	10 x 18	0.11	1.8	0.90	0.18	EBC00GL310EB0W
	220	10 x 25	0.11	0.80	0.40	0.34	EBC00GD322EB0W
40	10	6.5 x 18	0.10	16	7.5	0.046	EBC00DL210GB0W
	22	8 x 18	0.10	7.2	3.4	0.080	EBC00FL222GB0W
	47	8 x 18	0.09	3.0	1.6	0.12	EBC00FL247GB0W
	100	10 x 18	0.09	1.4	0.75	0.21	EBC00GL310GB0W
63	4.7	6.5 x 18	0.07	24	12	0.038	EBC00DL147JB0W
	10	8 x 18	0.07	11	5.5	0.064	EBC00FL210JB0W
	22	8 x 18	0.07	5.1	2.5	0.10	EBC00FL222JB0W
	47	10 x 18	0.07	2.4	1.2	0.17	EBC00GL247JB0W
100	4.7	6.5 x 18	0.06	20	9.6	0.048	EBC00DL147LB0W
	10	8 x 18	0.06	9.5	4.5	0.073	EBC00FL210LB0W
	22	10 x 18	0.06	4.3	2.0	0.13	EBC00GL222LB0W
	47	10 x 25	0.06	2.0	1.0	0.22	EBC00GD247LB0W
160	2.2	6.5 x 18	0.10	72	55	0.022	EBC00DL122MB0W
	4.7	8 x 18	0.10	34	26	0.037	EBC00FL147MB0W
	10	10 x 18	0.10	16	12	0.061	EBC00GL210MB0W
	22	10 x 25	0.10	7.2	5.5	0.12	EBC00GD222MB0W
250	2.2	8 x 18	0.10	72	50	0.025	EBC00FL122NB0W
	4.7	10 x 18	0.10	34	23	0.037	EBC00GL147NB0W
	10	10 x 25	0.10	16	11	0.066	EBC00GD210NB0W

ADDITIONAL ELECTRICAL DATA		
PARAMETER	CONDITIONS	VALUE
Voltage		
Surge voltage	$U_R \leq 100$ V	$U_s = 1.15 \times U_R$
	$U_R \geq 160$ V	$U_s = 1.10 \times U_R$
Reverse voltage	-	$U_{rev} \leq 1$ V
Current		
Leakage current	$U_R \leq 100$ V	$U_R, 300$ s
	$U_R \geq 160$ V	$U_R, 300$ s
		$I_L/\mu A \leq 0.0015 \times C_R/\mu F \times U_R/V + 3$ $I_L/\mu A \leq 0.0150 \times C_R/\mu F \times U_R/V + 10$

LOW TEMPERATURE BEHAVIOUR

Table for the calculation of the maximum 10 kHz impedance at low temperatures:

$$Z (10 \text{ kHz}) [\Omega] = \frac{\text{Tabular value}}{C_R [\mu\text{F}]}$$

T _a (°C)	RATED VOLTAGE (V)						
	16	25	40	63	100	160	250
- 25	2250	1500	850	600	450	1000	940
- 40	5400	3600	2040	1440	1080	5000	4600

The lower limit of the series resistance and impedance is determined by the ohmic part of the contact points and the foil resistance values. Therefore it will not always be possible to achieve calculated values below 0.05 Ω.

LIFETIME TABLE U_R ≤ 100 V

INTERRELATION BETWEEN ALTERNATING CURRENT, AMBIENT TEMPERATURE AND LIFETIME																				
I/I _R (FREQUENCY DEPENDENT)							LIFETIME MULTIPLIER L (depending on I/I _R and T _a)													
FREQUENCY [Hz]							AMBIENT TEMPERATURE T _a [°C]													
50	100	250	500	1000	> 2500	10 K	40	45	50	55	60	65	70	75	80	85	90	95	100	105
0	0	0	0	0	0	0	200	127	81	53	35	23	16	11	7.4	5.1	3.6	2.6	1.84	1.33
0.18	0.20	0.22	0.23	0.24	0.25	0.26	195	123	79	52	34	23	15	10	7.2	5.0	3.5	2.5	1.81	1.31
0.36	0.40	0.44	0.46	0.48	0.50	0.52	179	115	74	48	32	21	14	9.9	6.9	4.8	3.4	2.4	1.73	1.26
0.54	0.60	0.66	0.69	0.72	0.75	0.78	158	102	66	44	29	20	13	9.1	6.3	4.5	3.2	2.3	1.63	1.19
0.72	0.80	0.88	0.92	0.96	1.00	1.04	135	87	57	38	26	17	12	8.3	5.8	4.1	2.9	2.1	1.51	1.10
0.90	1.00	1.10	1.15	1.20	1.25	1.30	112	73	49	33	22	15	10	7.3	5.1	3.6	2.6	1.9	1.37	1.00
1.08	1.20	1.32	1.38	1.44	1.50	1.56	90	60	40	27	19	13	9.0	6.3	4.5	3.2	2.3	1.7	1.21	
1.26	1.40	1.54	1.61	1.68	1.75	1.82	70	47	32	22	15	11	7.5	5.3	3.8	2.7	2.0	1.4	1.06	
1.44	1.60	1.76	1.84	1.92	2.00	2.08	54	37	25	18	12	8.8	6.2	4.4	3.2	2.3	1.7	1.2		
1.62	1.80	1.98	2.07	2.16	2.25	2.34	40	28	20	14	9.9	7.0	5.0	3.6	2.6	1.9	1.4	1.0		
1.80	2.00	2.20	2.30	2.40	2.50	2.60	30	21	15	11	7.7	5.6	4.0	2.9	2.2	1.6	1.2			
1.98	2.20	2.42	2.53	2.64	2.75	2.86	22	16	11	8.2	6.0	4.3	3.2	2.3	1.7	1.3				
2.16	2.40	2.64	2.76	2.88	3.00	3.12	16	11	8.4	6.1	4.5	3.3	2.5	1.8	1.4	1.0				
2.34	2.60	2.86	2.99	3.12	3.25	3.38	11	8.3	6.1	4.6	3.4	2.5	1.9	1.4	1.1					
2.52	2.80	3.08	3.22	3.36	3.50	3.64	7.9	5.9	4.5	3.4	2.5	1.9	1.5	1.1						
2.70	3.00	3.30	3.45	3.60	3.75	3.90	5.5	4.2	3.2	2.5	1.9	1.4	1.1							
2.88	3.20	3.52	3.68	3.84	4.00	4.16	3.9	3.0	2.3	1.8	1.4	1.1								
3.06	3.40	3.74	3.91	4.08	4.25	4.42	2.7	2.1	1.6	1.3	1.0									
3.24	3.60	3.96	4.14	4.32	4.50	4.68	1.8	1.5	1.2											
3.42	3.80	4.18	4.37	4.56	4.75	4.94	1.3	1.0												

combination
not
permitted

I_R 100 Hz alternating current [A] at upper category temperature T_{UC} taken from datasheet

I User current [A]

T_a Ambient temperature of capacitor [°C]

L Lifetime multiplier

Regard L as a function of ambient temperature (x-axis) and of current (y-axis); use the current-axis according to the frequency



Aluminum Capacitors
Axial Capacitor Style

Vishay Roederstein

LIFETIME TABLE $U_R > 100\text{ V}$

INTERRELATION BETWEEN ALTERNATING CURRENT, AMBIENT TEMPERATURE AND LIFETIME																				
I_R (FREQUENCY DEPENDENT)							LIFETIME MULTIPLIER L (depending on I_R and T_a)													
FREQUENCY [Hz]							AMBIENT TEMPERATURE T_a [°C]													
50	100	250	500	1000	> 2500	10 K	40	45	50	55	60	65	70	75	80	85	90	95	100	105
0	0	0	0	0	0	0	200	127	81	53	35	23	16	11	7.4	5.1	3.6	2.6	1.84	1.33
0.17	0.20	0.23	0.25	0.26	0.27	0.28	194	123	79	52	34	23	15	10	7.2	5.0	3.5	2.5	1.81	1.31
0.34	0.40	0.46	0.50	0.52	0.54	0.56	178	114	74	48	32	21	14	9.9	6.9	4.8	3.4	2.4	1.73	1.26
0.51	0.60	0.70	0.74	0.78	0.80	0.84	158	102	66	44	29	20	13	9.1	6.3	4.5	3.2	2.3	1.63	1.19
0.68	0.80	0.93	0.99	1.04	1.07	1.12	133	87	57	38	26	17	12	8.3	5.8	4.1	2.9	2.1	1.51	1.10
0.85	1.00	1.16	1.24	1.30	1.34	1.40	110	73	49	33	22	15	11	7.3	5.1	3.6	2.6	1.9	1.37	1.00
1.02	1.20	1.39	1.49	1.56	1.61	1.68	88	59	40	27	19	13	9.0	6.3	4.5	3.2	2.3	1.7	1.21	
1.19	1.40	1.62	1.74	1.82	1.88	1.96	69	47	32	22	15	11	7.6	5.4	3.8	2.7	2.00	1.4	1.06	
1.36	1.60	1.86	1.98	2.08	2.14	2.24	53	37	26	18	12	8.8	6.2	4.5	3.2	2.3	1.7	1.2		
1.53	1.80	2.09	2.23	2.34	2.41	2.52	40	28	20	14	9.9	7.1	5.1	3.7	2.7	1.9	1.4	1.0		
1.70	2.00	2.32	2.48	2.60	2.68	2.80	30	21	15	11	7.8	5.6	4.1	3	2.2	1.6	1.2			
1.87	2.20	2.55	2.73	2.86	2.95	3.08	22	16	11	8.3	6.0	4.4	3.2	2.4	1.7	1.3				
2.04	2.40	2.78	2.98	3.12	3.22	3.36	16	12	8.5	6.2	4.6	3.4	2.5	1.9	1.4	1.0				
2.21	2.60	3.02	3.22	3.38	3.48	3.64	11	8.4	6.2	4.6	3.5	2.6	1.9	1.4	1.1					
2.38	2.80	3.25	3.47	3.64	3.75	3.92	8.0	6.0	4.5	3.4	2.6	1.9	1.5	1.1						
2.55	3.00	3.48	3.72	3.90	4.02	4.20	5.6	4.3	3.3	2.5	1.9	1.4	1.1							
2.72	3.20	3.71	3.97	4.16	4.29	4.48	3.9	3.0	2.3	1.8	1.4	1.1								
2.89	3.40	3.94	4.22	4.42	4.56	4.76	2.7	2.1	1.7	1.3	1.0									
3.06	3.60	4.18	4.46	4.68	4.82	5.04	1.9	1.5	1.2											
3.23	3.80	4.41	4.71	4.94	5.09	5.32	1.3	1.0												

combination not permitted

I_R 100 Hz alternating current [A] at upper category temperature T_{UC} taken from datasheet

I User current [A]

T_a Ambient temperature of capacitor [°C]

L Lifetime multiplier

Regard L as a function of ambient temperature (x-axis) and of current (y-axis); use the current-axis according to the frequency

TEST PROCEDURES AND REQUIREMENTS			
TEST		PROCEDURE (quick reference)	REQUIREMENTS
NAME OF TEST	REFERENCE		
Endurance	IEC 60384-4/ EN 130300 subclause 4.13	$T_A = 105\text{ °C}$; U_R applied 2000 h	- $15\% \leq \Delta C/C \leq 15\%$ tan $\delta \leq 1.3 \times$ spec. limit $Z \leq 2 \times$ spec. limit $I_L (300\text{ s}) \leq$ spec. limit
Useful life	CECC 30301 subclause 1.8.1	$T_A = 105\text{ °C}$; U_R and I_R applied $16\text{ V} \leq U_R \leq 100\text{ V}$ Cases 6.5 x 8 to 10 x 25: 3000 h $160\text{ V} \leq U_R \leq 250\text{ V}$ Cases 6.5 x 8 to 10 x 25: 3000 h	- $45\% \leq \Delta C/C \leq 45\%$ tan $\delta \leq 3 \times$ spec. limit $Z \leq 3 \times$ spec. limit $I_L (300\text{ s}) \leq$ spec. limit No short or open circuit Total failure percentage: $\leq 1\%$
Shelf life (storage at high temperature)	IEC 60384-4/ EN 130300 subclause 4.17	$T_A = 105\text{ °C}$; no voltage applied 100 h After test: U_R to be applied for 30 minutes 24 hours o 48 hours before measurement	- $15\% \leq \Delta C/C \leq 15\%$ tan $\delta \leq 1.3 \times$ spec. limit $Z \leq 2 \times$ spec. limit $I_L (300\text{ s}) \leq 2 \times$ spec. limit



Disclaimer

All product specifications and data are subject to change without notice.

Vishay Intertechnology, Inc., its affiliates, agents, and employees, and all persons acting on its or their behalf (collectively, "Vishay"), disclaim any and all liability for any errors, inaccuracies or incompleteness contained herein or in any other disclosure relating to any product.

Vishay disclaims any and all liability arising out of the use or application of any product described herein or of any information provided herein to the maximum extent permitted by law. The product specifications do not expand or otherwise modify Vishay's terms and conditions of purchase, including but not limited to the warranty expressed therein, which apply to these products.

No license, express or implied, by estoppel or otherwise, to any intellectual property rights is granted by this document or by any conduct of Vishay.

The products shown herein are not designed for use in medical, life-saving, or life-sustaining applications unless otherwise expressly indicated. Customers using or selling Vishay products not expressly indicated for use in such applications do so entirely at their own risk and agree to fully indemnify Vishay for any damages arising or resulting from such use or sale. Please contact authorized Vishay personnel to obtain written terms and conditions regarding products designed for such applications.

Product names and markings noted herein may be trademarks of their respective owners.