

Solid-Electrolyte TANTALEX™ Capacitors, Hermetically-Sealed, Axial-Lead



PERFORMANCE CHARACTERISTICS

Operating Temperature: -55 °C to +125 °C (above 85 °C, voltage derating is required)
Capacitance Tolerance: at 120 Hz, +25 °C ± 20 %, ± 10 % standard. ± 5 % available as special
Dissipation Factor: at 120 Hz, +25 °C

DC Leakage Current (DCL Max.):

at +25 °C: leakage current shall not exceed the values listed in the Standard Ratings table

at +85 °C: leakage current shall not exceed 10 times the values listed in the Standard Ratings table

at +125 °C: leakage shall not exceed 15 times the values listed in the Standard Ratings table

Life Test: capacitors shall withstand rated DC voltage applied at +85 °C for 2000 h or derated DC voltage applied at +125 °C for 1000 h

Following the life test:

1. DCL shall not exceed 125 % of the initial requirement
2. Dissipation factor shall meet the initial requirement
3. Change in capacitance shall not exceed ± 5 %

FEATURES

- Terminations: tin / lead (SnPb), 100 % tin (RoHS-compliant)
- These high performance, hermetically-sealed TANTALEX capacitors have set the standard for solid-electrolyte tantalum capacitors for more than three decades
- High capacitance, low DCL, low dissipation factor and exceptional operating stability
- Performance and reliability have been proven in commercial, industrial and military applications
- Available in four case codes and capacitors and are supplied with plastic-film insulation
- Terminals are solid, tinned nickel wire leads
- The military equivalent of the 150D is the M39003/01 (style CSR13) which is qualified to MIL-PRF-39003/1
- Material categorization: for definitions of compliance please see www.vishay.com/doc/299912



Available
RoHS*
 Available
HALOGEN FREE

Note

* This datasheet provides information about parts that are RoHS-compliant and / or parts that are non-RoHS-compliant. For example, parts with lead (Pb) terminations are not RoHS-compliant. Please see the information / tables in this datasheet for details.

勝特力材料 886-3-5753170
 勝特力电子(上海) 86-21-34970699
 勝特力电子(深圳) 86-755-83298787
[Http://www.100y.com.tw](http://www.100y.com.tw)

ORDERING INFORMATION							
150D	224	X0	006	A	2	T	E3
MODEL	CAPACITANCE	CAPACITANCE TOLERANCE	DC VOLTAGE RATING AT 85 °C	CASE CODE	STYLE NUMBER	PACKAGING	RoHS-COMPLIANT
	This is expressed in picofarads. The first two digits are the significant figures. The third is the number of zeros to follow.	X0 = ± 20 % X9 = ± 10 % X5 = ± 5 % * * Special order	This is expressed in volts. To complete the three-digit block, zeros precede the voltage rating.	See Ratings and Case Codes table	0 = no sleeve 2 = insulated sleeve	B = bulk T = tape and reel G = ammo pack	E3 = 100 % tin termination (RoHS-compliant) Blank = SnPb termination

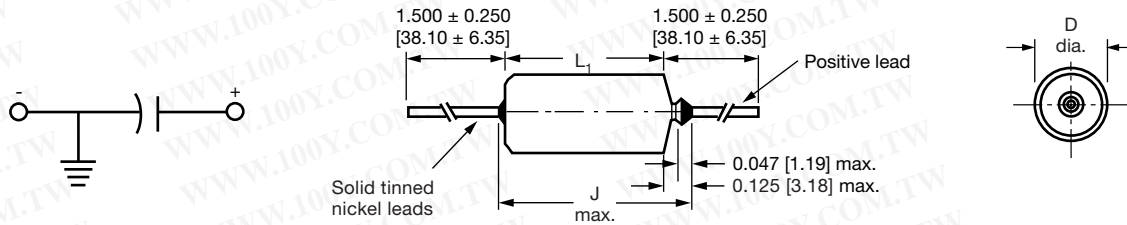
DIMENSIONS in inches [millimeters]

CASE CODE	D	L ₁	J	LEAD SIZE	
	WITH INSULATING SLEEVE ⁽¹⁾		(MAXIMUM)	AWG NO.	NOMINAL DIAMETER
A	0.135 ± 0.016 [3.43 ± 0.41]	0.286 ± 0.031 [7.26 ± 0.79]	0.422 [10.720]	24	0.020 [0.51]
B	0.185 ± 0.016 [4.70 ± 0.41]	0.474 ± 0.031 [12.04 ± 0.79]	0.610 [15.490]	24	0.020 [0.51]
R	0.289 ± 0.016 [7.34 ± 0.41]	0.686 ± 0.031 [17.42 ± 0.79]	0.822 [20.880]	22	0.025 [0.64]
S	0.351 ± 0.016 [8.92 ± 0.41]	0.786 ± 0.031 [19.96 ± 0.79]	0.922 [23.420]	22	0.025 [0.64]

Note

⁽¹⁾ When a shrink-fitted insulation is used, it shall lap over the ends of the capacitor body

STANDARD RATINGS

CAPACITANCE (μ F)	CASE CODE	PART NUMBER	MAX. DCL AT +25 °C (μ A)	MAX. DF AT +25 °C 120 Hz (%)
6 V_{DC} AT +85 °C, SURGE = 8 V; 4 V_{DC} AT +125 °C, SURGE = 5 V				
0.22	A	150D224(1)006A(2)(3)(4)	0.5	2
0.27	A	150D274(1)006A(2)(3)(4)	0.5	2
0.33	A	150D334(1)006A(2)(3)(4)	0.5	2
0.39	A	150D394(1)006A(2)(3)(4)	0.5	2
0.47	A	150D474(1)006A(2)(3)(4)	0.5	2
0.56	A	150D564(1)006A(2)(3)(4)	0.5	2
0.68	A	150D684(1)006A(2)(3)(4)	0.5	2
0.82	A	150D824(1)006A(2)(3)(4)	0.5	2
1.0	A	150D105(1)006A(2)(3)(4)	0.5	2
1.2	A	150D125(1)006A(2)(3)(4)	0.5	4
1.5	A	150D155(1)006A(2)(3)(4)	0.5	4
1.8	A	150D185(1)006A(2)(3)(4)	0.5	4
2.2	A	150D225(1)006A(2)(3)(4)	0.5	4
2.7	A	150D275(1)006A(2)(3)(4)	0.5	4
3.3	A	150D335(1)006A(2)(3)(4)	0.5	4
3.9	A	150D395(1)006A(2)(3)(4)	0.5	4
4.7	A	150D475(1)006A(2)(3)(4)	0.5	4
5.6	A	150D565(1)006A(2)(3)(4)	0.5	4
6.8	A	150D685(1)006A(2)(3)(4)	0.5	6
8.2	B	150D825(1)006B(2)(3)(4)	0.5	6
10	B	150D106(1)006B(2)(3)(4)	0.5	6
12	B	150D126(1)006B(2)(3)(4)	0.5	6
15	B	150D156(1)006B(2)(3)(4)	1.0	6
18	B	150D186(1)006B(2)(3)(4)	1.0	6

Note

- Part number definitions:
 - For 10 % tolerance specify "X9"; for 20 % specify "X0"; for 5 % "X5" (special order)
 - Style number: 0 = no sleeve, 2 = insulated sleeve
 - Packaging options: B = bulk, T = tape and reel, G = ammo pack
 - Termination: E3 = 100 % tin, blank = SnPb



STANDARD RATINGS					
CAPACITANCE (μF)	CASE CODE	PART NUMBER	MAX. DCL AT +25 °C (μA)	MAX. DF AT +25 °C 120 Hz (%)	
6 V_{DC} AT +85 °C, SURGE = 8 V; 4 V_{DC} AT +125 °C, SURGE = 5 V					
22	B	150D226(1)006B(2)(3)(4)	1.0	6	
27	B	150D276(1)006B(2)(3)(4)	1.0	6	
33	B	150D336(1)006B(2)(3)(4)	1.0	6	
39	B	150D396(1)006B(2)(3)(4)	1.0	6	
47	B	150D476(1)006B(2)(3)(4)	2.0	6	
56	B	150D566(1)006B(2)(3)(4)	2.0	6	
68	R	150D686(1)006R(2)(3)(4)	3.0	6	
82	R	150D826(1)006R(2)(3)(4)	3.0	6	
100	R	150D107(1)006R(2)(3)(4)	3.0	6	
120	R	150D127(1)006R(2)(3)(4)	3.0	6	
150	R	150D157(1)006R(2)(3)(4)	6.0	6	
180	R	150D187(1)006R(2)(3)(4)	6.0	6	
220	S	150D227(1)006S(2)(3)(4)	6.0	8	
270	S	150D277(1)006S(2)(3)(4)	6.0	8	
330	S	150D337(1)006S(2)(3)(4)	10.0	8	
10 V_{DC} AT +85 °C, SURGE = 13 V; 7 V_{DC} AT +125 °C, SURGE = 9 V					
0.22	A	150D224(1)010A(2)(3)(4)	0.5	2	
0.27	A	150D274(1)010A(2)(3)(4)	0.5	2	
0.33	A	150D334(1)010A(2)(3)(4)	0.5	2	
0.39	A	150D394(1)010A(2)(3)(4)	0.5	2	
0.47	A	150D474(1)010A(2)(3)(4)	0.5	2	
0.56	A	150D564(1)010A(2)(3)(4)	0.5	2	
0.68	A	150D684(1)010A(2)(3)(4)	0.5	2	
0.82	A	150D824(1)010A(2)(3)(4)	0.5	2	
1.0	A	150D105(1)010A(2)(3)(4)	0.5	2	
1.2	A	150D125(1)010A(2)(3)(4)	0.5	4	
1.5	A	150D155(1)010A(2)(3)(4)	0.5	4	
1.8	A	150D185(1)010A(2)(3)(4)	0.5	4	
2.2	A	150D225(1)010A(2)(3)(4)	0.5	4	
2.7	A	150D275(1)010A(2)(3)(4)	0.5	4	
3.3	A	150D335(1)010A(2)(3)(4)	0.5	4	
3.9	A	150D395(1)010A(2)(3)(4)	0.5	4	
4.7	A	150D475(1)010A(2)(3)(4)	0.5	4	
5.6	B	150D565(1)010B(2)(3)(4)	0.5	4	
6.8	B	150D685(1)010B(2)(3)(4)	1.0	6	
8.2	B	150D825(1)010B(2)(3)(4)	1.0	6	
10	B	150D106(1)010B(2)(3)(4)	1.0	6	
12	B	150D126(1)010B(2)(3)(4)	1.0	6	
15	B	150D156(1)010B(2)(3)(4)	1.0	6	
18	B	150D186(1)010B(2)(3)(4)	1.0	6	
22	B	150D226(1)010B(2)(3)(4)	2.0	6	
27	B	150D276(1)010B(2)(3)(4)	2.0	6	

Note

- Part number definitions:
 - For 10 % tolerance specify "X9"; for 20 % specify "X0"; for 5 % "X5" (special order)
 - Style number: 0 = no sleeve, 2 = insulated sleeve
 - Packaging options: B = bulk, T = tape and reel, G = ammo pack
 - Termination: E3 = 100 % tin, blank = SnPb



STANDARD RATINGS				
CAPACITANCE (μ F)	CASE CODE	PART NUMBER	MAX. DCL AT +25 °C (μ A)	MAX. DF AT +25 °C 120 Hz (%)
10 V_{DC} AT +85 °C, SURGE = 13 V; 7 V_{DC} AT +125 °C, SURGE = 9 V				
33	B	150D336(1)010B(2)(3)(4)	2.0	6
39	B	150D396(1)010B(2)(3)(4)	2.0	6
47	R	150D476(1)010R(2)(3)(4)	3.0	6
56	R	150D566(1)010R(2)(3)(4)	3.0	6
68	R	150D686(1)010R(2)(3)(4)	3.0	6
82	R	150D826(1)010R(2)(3)(4)	3.0	6
100	R	150D107(1)010R(2)(3)(4)	6.0	6
120	R	150D127(1)010R(2)(3)(4)	6.0	6
150	S	150D157(1)010S(2)(3)(4)	10.0	6
180	S	150D187(1)010S(2)(3)(4)	10.0	6
220	S	150D227(1)010S(2)(3)(4)	10.0	8
15 V_{DC} AT +85 °C, SURGE = 20 V; 10 V_{DC} AT +125 °C, SURGE = 12 V				
0.22	A	150D224(1)015A(2)(3)(4)	0.5	2
0.27	A	150D274(1)015A(2)(3)(4)	0.5	2
0.33	A	150D334(1)015A(2)(3)(4)	0.5	2
0.39	A	150D394(1)015A(2)(3)(4)	0.5	2
0.47	A	150D474(1)015A(2)(3)(4)	0.5	2
0.56	A	150D564(1)015A(2)(3)(4)	0.5	2
0.68	A	150D684(1)015A(2)(3)(4)	0.5	2
0.82	A	150D824(1)015A(2)(3)(4)	0.5	2
1.0	A	150D105(1)015A(2)(3)(4)	0.5	2
1.2	A	150D125(1)015A(2)(3)(4)	0.5	4
1.5	A	150D155(1)015A(2)(3)(4)	0.5	4
1.8	A	150D185(1)015A(2)(3)(4)	0.5	4
2.2	A	150D225(1)015A(2)(3)(4)	0.5	4
2.7	A	150D275(1)015A(2)(3)(4)	0.5	4
3.3	A	150D335(1)015A(2)(3)(4)	0.5	4
3.9	B	150D395(1)015B(2)(3)(4)	0.5	4
4.7	B	150D475(1)015B(2)(3)(4)	1.0	4
5.6	B	150D565(1)015B(2)(3)(4)	1.0	4
6.8	B	150D685(1)015B(2)(3)(4)	1.0	6
8.2	B	150D825(1)015B(2)(3)(4)	1.0	6
10	B	150D106(1)015B(2)(3)(4)	1.0	6
12	B	150D126(1)015B(2)(3)(4)	1.0	6
15	B	150D156(1)015B(2)(3)(4)	2.0	6
18	B	150D186(1)015B(2)(3)(4)	2.0	6
22	B	150D226(1)015B(2)(3)(4)	3.0	6
27	R	150D276(1)015R(2)(3)(4)	3.0	6
33	R	150D336(1)015R(2)(3)(4)	3.0	6
39	R	150D396(1)015R(2)(3)(4)	3.0	6
47	R	150D476(1)015R(2)(3)(4)	6.0	6
56	R	150D566(1)015R(2)(3)(4)	6.0	6

Note

- Part number definitions:
 - For 10 % tolerance specify "X9"; for 20 % specify "X0"; for 5 % "X5" (special order)
 - Style number: 0 = no sleeve, 2 = insulated sleeve
 - Packaging options: B = bulk, T = tape and reel, G = ammo pack
 - Termination: E3 = 100 % tin, blank = SnPb



STANDARD RATINGS				
CAPACITANCE (μ F)	CASE CODE	PART NUMBER	MAX. DCL AT +25 °C (μ A)	MAX. DF AT +25 °C 120 Hz (%)
15 V_{DC} AT +85 °C, SURGE = 20 V; 10 V_{DC} AT +125 °C, SURGE = 12 V				
68	R	150D686(1)015R(2)(3)(4)	6.0	6
82	S	150D826(1)015S(2)(3)(4)	6.0	6
100	S	150D107(1)015S(2)(3)(4)	6.0	6
120	S	150D127(1)015S(2)(3)(4)	6.0	6
150	S	150D157(1)015S(2)(3)(4)	10.0	6
20 V_{DC} AT +85 °C, SURGE = 26 V; 13 V_{DC} AT +125 °C, SURGE = 16 V				
0.033	A	150D333(1)020A(2)(3)(4)	0.1	2
0.039	A	150D393(1)020A(2)(3)(4)	0.1	2
0.047	A	150D473(1)020A(2)(3)(4)	0.1	2
0.056	A	150D563(1)020A(2)(3)(4)	0.1	2
0.068	A	150D683(1)020A(2)(3)(4)	0.1	2
0.082	A	150D823(1)020A(2)(3)(4)	0.1	2
0.10	A	150D104(1)020A(2)(3)(4)	0.5	2
0.12	A	150D124(1)020A(2)(3)(4)	0.5	2
0.15	A	150D154(1)020A(2)(3)(4)	0.5	2
0.18	A	150D184(1)020A(2)(3)(4)	0.5	2
0.22	A	150D224(1)020A(2)(3)(4)	0.5	2
0.27	A	150D274(1)020A(2)(3)(4)	0.5	2
0.33	A	150D334(1)020A(2)(3)(4)	0.5	2
0.39	A	150D394(1)020A(2)(3)(4)	0.5	2
0.47	A	150D474(1)020A(2)(3)(4)	0.5	2
0.56	A	150D564(1)020A(2)(3)(4)	0.5	2
0.68	A	150D684(1)020A(2)(3)(4)	0.5	2
0.82	A	150D824(1)020A(2)(3)(4)	0.5	2
1.0	A	150D105(1)020A(2)(3)(4)	0.5	2
1.2	A	150D125(1)020A(2)(3)(4)	0.5	4
1.5	A	150D155(1)020A(2)(3)(4)	0.5	4
1.8	A	150D185(1)020A(2)(3)(4)	0.5	4
2.2	A	150D225(1)020A(2)(3)(4)	0.5	4
2.7	B	150D275(1)020B(2)(3)(4)	0.5	4
3.3	B	150D335(1)020B(2)(3)(4)	0.5	4
3.9	B	150D395(1)020B(2)(3)(4)	1.0	4
4.7	B	150D475(1)020B(2)(3)(4)	1.0	4
5.6	B	150D565(1)020B(2)(3)(4)	1.0	4
6.8	B	150D685(1)020B(2)(3)(4)	1.0	6
8.2	B	150D825(1)020B(2)(3)(4)	1.0	6
10	B	150D106(1)020B(2)(3)(4)	1.0	6
12	B	150D126(1)020B(2)(3)(4)	1.0	6
15	B	150D156(1)020B(2)(3)(4)	2.0	6
18	R	150D186(1)020R(2)(3)(4)	3.0	6
22	R	150D226(1)020R(2)(3)(4)	3.0	6
27	R	150D276(1)020R(2)(3)(4)	3.0	6

Note

- Part number definitions:
 - For 10 % tolerance specify "X9"; for 20 % specify "X0"; for 5 % "X5" (special order)
 - Style number: 0 = no sleeve, 2 = insulated sleeve
 - Packaging options: B = bulk, T = tape and reel, G = ammo pack
 - Termination: E3 = 100 % tin, blank = SnPb



STANDARD RATINGS				
CAPACITANCE (μ F)	CASE CODE	PART NUMBER	MAX. DCL AT +25 °C (μ A)	MAX. DF AT +25 °C 120 Hz (%)
20 V_{DC} AT +85 °C, SURGE = 26 V; 13 V_{DC} AT +125 °C, SURGE = 16 V				
33	R	150D336(1)020R(2)(3)(4)	3.0	6
39	R	150D396(1)020R(2)(3)(4)	3.0	6
47	R	150D476(1)020R(2)(3)(4)	6.0	6
56	S	150D566(1)020S(2)(3)(4)	6.0	6
68	S	150D686(1)020S(2)(3)(4)	6.0	6
82	S	150D826(1)020S(2)(3)(4)	6.0	6
100	S	150D107(1)020S(2)(3)(4)	10.0	6
25 V_{DC} AT +85 °C, SURGE = 32 V; 17 V_{DC} AT +125 °C, SURGE = 21 V				
1.2	A	150D125(1)025A(2)(3)(4)	0.5	4
1.5	A	150D155(1)025A(2)(3)(4)	0.5	4
1.8	A	150D185(1)025A(2)(3)(4)	0.5	4
4.7	B	150D475(1)025B(2)(3)(4)	1.2	4
5.6	B	150D565(1)025B(2)(3)(4)	1.4	4
6.8	B	150D685(1)025B(2)(3)(4)	1.7	4
8.2	B	150D825(1)025B(2)(3)(4)	2.1	4
10	B	150D106(1)025B(2)(3)(4)	2.5	6
15	B	150D156(1)025B(2)(3)(4)	3.8	6
33	R	150D336(1)025R(2)(3)(4)	8.3	6
68	S	150D686(1)025S(2)(3)(4)	17	6
100	S	150D107(1)025S(2)(3)(4)	25	6
35 V_{DC} AT +85 °C, SURGE = 46 V; 23 V_{DC} AT +125 °C, SURGE = 28 V				
0.033	A	150D333(1)035A(2)(3)(4)	0.1	2
0.039	A	150D393(1)035A(2)(3)(4)	0.1	2
0.047	A	150D473(1)035A(2)(3)(4)	0.1	2
0.056	A	150D563(1)035A(2)(3)(4)	0.1	2
0.068	A	150D683(1)035A(2)(3)(4)	0.1	2
0.082	A	150D823(1)035A(2)(3)(4)	0.1	2
0.10	A	150D104(1)035A(2)(3)(4)	0.5	2
0.12	A	150D124(1)035A(2)(3)(4)	0.5	2
0.15	A	150D154(1)035A(2)(3)(4)	0.5	2
0.18	A	150D184(1)035A(2)(3)(4)	0.5	2
0.22	A	150D224(1)035A(2)(3)(4)	0.5	2
0.27	A	150D274(1)035A(2)(3)(4)	0.5	2
0.33	A	150D334(1)035A(2)(3)(4)	0.5	2
0.39	A	150D394(1)035A(2)(3)(4)	0.5	2
0.47	A	150D474(1)035A(2)(3)(4)	0.5	2
0.56	A	150D564(1)035A(2)(3)(4)	0.5	2
0.68	A	150D684(1)035A(2)(3)(4)	0.5	2
0.82	A	150D824(1)035A(2)(3)(4)	0.5	2
1.0	A	150D105(1)035A(2)(3)(4)	0.5	2
1.2	B	150D125(1)035B(2)(3)(4)	0.5	4
1.5	B	150D155(1)035B(2)(3)(4)	0.5	4

Note

- Part number definitions:
 - For 10 % tolerance specify "X9"; for 20 % specify "X0"; for 5 % "X5" (special order)
 - Style number: 0 = no sleeve, 2 = insulated sleeve
 - Packaging options: B = bulk, T = tape and reel, G = ammo pack
 - Termination: E3 = 100 % tin, blank = SnPb



STANDARD RATINGS					
CAPACITANCE (μ F)	CASE CODE	PART NUMBER	MAX. DCL AT +25 °C (μ A)	MAX. DF AT +25 °C 120 Hz (%)	
35 V_{DC} AT +85 °C, SURGE = 46 V; 23 V_{DC} AT +125 °C, SURGE = 28 V					
1.8	B	150D185(1)035B(2)(3)(4)	0.5	4	
2.2	B	150D225(1)035B(2)(3)(4)	1.0	4	
2.7	B	150D275(1)035B(2)(3)(4)	1.0	4	
3.3	B	150D335(1)035B(2)(3)(4)	1.0	4	
3.9	B	150D395(1)035B(2)(3)(4)	1.0	4	
4.7	B	150D475(1)035B(2)(3)(4)	1.0	4	
5.6	B	150D565(1)035B(2)(3)(4)	1.0	4	
6.8	B	150D685(1)035B(2)(3)(4)	2.0	4	
8.2	R	150D825(1)035R(2)(3)(4)	3.0	4	
10	R	150D106(1)035R(2)(3)(4)	3.0	4	
12	R	150D126(1)035R(2)(3)(4)	3.0	4	
15	R	150D156(1)035R(2)(3)(4)	3.0	4	
18	R	150D186(1)035R(2)(3)(4)	3.0	4	
22	R	150D226(1)035R(2)(3)(4)	6.0	4	
27	S	150D276(1)035S(2)(3)(4)	6.0	4	
33	S	150D336(1)035S(2)(3)(4)	6.0	4	
39	S	150D396(1)035S(2)(3)(4)	6.0	4	
47	S	150D476(1)035S(2)(3)(4)	10.0	4	
50 V_{DC} AT +85 °C, SURGE = 65 V; 33 V_{DC} AT +125 °C, SURGE = 40 V					
0.056	A	150D563(1)050A(2)(3)(4)	0.1	2	
0.068	A	150D683(1)050A(2)(3)(4)	0.1	2	
0.082	A	150D823(1)050A(2)(3)(4)	0.1	2	
0.10	A	150D104(1)050A(2)(3)(4)	0.5	2	
0.12	A	150D124(1)050A(2)(3)(4)	0.5	2	
0.15	A	150D154(1)050A(2)(3)(4)	0.5	2	
0.18	A	150D184(1)050A(2)(3)(4)	0.5	2	
0.22	A	150D224(1)050A(2)(3)(4)	0.5	2	
0.27	A	150D274(1)050A(2)(3)(4)	0.5	2	
0.33	A	150D334(1)050A(2)(3)(4)	0.5	2	
0.39	A	150D394(1)050A(2)(3)(4)	0.5	2	
0.47	A	150D474(1)050A(2)(3)(4)	0.5	2	
0.56	A	150D564(1)050A(2)(3)(4)	0.5	2	
0.68	A	150D684(1)050A(2)(3)(4)	0.5	2	
0.82	A	150D824(1)050A(2)(3)(4)	0.5	2	
1.0	A	150D105(1)050A(2)(3)(4)	0.5	2	
1.2	B	150D125(1)050B(2)(3)(4)	0.5	4	
1.5	B	150D155(1)050B(2)(3)(4)	0.5	4	
1.8	B	150D185(1)050B(2)(3)(4)	0.5	4	
2.2	B	150D225(1)050B(2)(3)(4)	1.0	4	
2.7	B	150D275(1)050B(2)(3)(4)	1.0	4	
3.3	B	150D335(1)050B(2)(3)(4)	2.0	4	
3.9	B	150D395(1)050B(2)(3)(4)	2.0	4	

Note

- Part number definitions:
 - For 10 % tolerance specify "X9"; for 20 % specify "X0"; for 5 % "X5" (special order)
 - Style number: 0 = no sleeve, 2 = insulated sleeve
 - Packaging options: B = bulk, T = tape and reel, G = ammo pack
 - Termination: E3 = 100 % tin, blank = SnPb



STANDARD RATINGS				
CAPACITANCE (μ F)	CASE CODE	PART NUMBER	MAX. DCL AT +25 °C (μ A)	MAX. DF AT +25 °C 120 Hz (%)
50 V_{DC} AT +85 °C, SURGE = 65 V; 33 V_{DC} AT +125 °C, SURGE = 40 V				
4.7	B	150D475(1)050B(2)(3)(4)	3.0	4
5.6	R	150D565(1)050R(2)(3)(4)	3.0	4
6.8	R	150D685(1)050R(2)(3)(4)	3.0	4
8.2	R	150D825(1)050R(2)(3)(4)	3.0	4
10	R	150D106(1)050R(2)(3)(4)	3.0	4
12	R	150D126(1)050R(2)(3)(4)	3.0	4
15	R	150D156(1)050R(2)(3)(4)	6.0	4
18	R	150D186(1)050R(2)(3)(4)	6.0	4
22	S	150D226(1)050S(2)(3)(4)	6.0	4
60 V_{DC} AT +85 °C, SURGE = 78 V; 40 V_{DC} AT +125 °C, SURGE = 49 V				
0.10	A	150D104(1)060A(2)(3)(4)	0.5	4.0
0.12	A	150D124(1)060A(2)(3)(4)	0.5	4.0
0.15	A	150D154(1)060A(2)(3)(4)	0.5	4.0
0.18	A	150D184(1)060A(2)(3)(4)	0.5	4.0
0.22	A	150D224(1)060A(2)(3)(4)	0.5	4.0
0.27	A	150D274(1)060A(2)(3)(4)	0.5	4.0
0.33	A	150D334(1)060A(2)(3)(4)	0.5	4.0
0.39	A	150D394(1)060A(2)(3)(4)	0.5	4.0
0.47	A	150D474(1)060A(2)(3)(4)	0.5	4.0
0.56	A	150D564(1)060A(2)(3)(4)	0.5	4.0
0.68	A	150D684(1)060A(2)(3)(4)	0.5	4.0
1.0	B	150D105(1)060B(2)(3)(4)	0.5	4.0
2.2	B	150D225(1)060B(2)(3)(4)	1.0	4.0
4.7	R	150D475(1)060R(2)(3)(4)	3.0	6.0
5.6	R	150D565(1)060R(2)(3)(4)	3.0	6.0
6.8	R	150D685(1)060R(2)(3)(4)	4.0	6.0
8.2	R	150D825(1)060R(2)(3)(4)	5.0	6.0
10	R	150D106(1)060R(2)(3)(4)	6.0	6.0
12	S	150D126(1)060S(2)(3)(4)	6.0	6.0
15	S	150D156(1)060S(2)(3)(4)	9.0	6.0
18	S	150D186(1)060S(2)(3)(4)	10.0	6.0
22	S	150D226(1)060S(2)(3)(4)	12.0	6.0
75 V_{DC} AT +85 °C, SURGE = 98 V; 50 V_{DC} AT +125 °C, SURGE = 64 V				
0.033	A	150D333(1)075A(2)(3)(4)	0.5	2
0.039	A	150D393(1)075A(2)(3)(4)	0.5	2
0.047	A	150D473(1)075A(2)(3)(4)	0.5	2
0.056	A	150D563(1)075A(2)(3)(4)	0.5	2
0.068	A	150D683(1)075A(2)(3)(4)	0.5	2
0.082	A	150D823(1)075A(2)(3)(4)	0.5	2
0.10	A	150D104(1)075A(2)(3)(4)	0.5	2
0.12	A	150D124(1)075A(2)(3)(4)	0.5	2
0.15	A	150D154(1)075A(2)(3)(4)	0.5	2

Note

- Part number definitions:
 - For 10 % tolerance specify "X9"; for 20 % specify "X0"; for 5 % "X5" (special order)
 - Style number: 0 = no sleeve, 2 = insulated sleeve
 - Packaging options: B = bulk, T = tape and reel, G = ammo pack
 - Termination: E3 = 100 % tin, blank = SnPb



STANDARD RATINGS				
CAPACITANCE (μ F)	CASE CODE	PART NUMBER	MAX. DCL AT +25 °C (μ A)	MAX. DF AT +25 °C 120 Hz (%)
75 V_{DC} AT +85 °C, SURGE = 98 V; 50 V_{DC} AT +125 °C, SURGE = 64 V				
0.18	A	150D184(1)075A(2)(3)(4)	0.5	2
0.22	A	150D224(1)075A(2)(3)(4)	0.5	2
0.27	A	150D274(1)075A(2)(3)(4)	0.5	2
0.33	A	150D334(1)075A(2)(3)(4)	0.5	2
0.39	A	150D394(1)075A(2)(3)(4)	0.5	2
0.47	A	150D474(1)075A(2)(3)(4)	0.5	2
0.56	A	150D564(1)075A(2)(3)(4)	0.5	2
0.68	A	150D684(1)075A(2)(3)(4)	0.5	2
0.82	B	150D824(1)075B(2)(3)(4)	0.5	2
1.0	B	150D105(1)075B(2)(3)(4)	0.5	2
1.2	B	150D125(1)075B(2)(3)(4)	0.5	4
1.5	B	150D155(1)075B(2)(3)(4)	1.0	4
1.8	B	150D185(1)075B(2)(3)(4)	1.0	4
2.2	B	150D225(1)075B(2)(3)(4)	1.0	4
2.7	B	150D275(1)075B(2)(3)(4)	1.0	4
3.3	B	150D335(1)075B(2)(3)(4)	2.0	4
3.9	B	150D395(1)075B(2)(3)(4)	2.0	4
4.7	R	150D475(1)075R(2)(3)(4)	4.0	4
5.6	R	150D565(1)075R(2)(3)(4)	4.0	4
6.8	R	150D685(1)075R(2)(3)(4)	6.0	4
8.2	R	150D825(1)075R(2)(3)(4)	6.0	4
10	R	150D106(1)075R(2)(3)(4)	8.0	4
12	S	150D126(1)075S(2)(3)(4)	10.0	4
15	S	150D156(1)075S(2)(3)(4)	12.0	4
100 V_{DC} AT +85 °C, SURGE = 130 V; 67 V_{DC} AT +125 °C, SURGE = 86 V				
0.033	A	150D333(1)100A(2)(3)(4)	0.5	2
0.039	A	150D393(1)100A(2)(3)(4)	0.5	2
0.047	A	150D473(1)100A(2)(3)(4)	0.5	2
0.056	A	150D563(1)100A(2)(3)(4)	0.5	2
0.068	A	150D683(1)100A(2)(3)(4)	0.5	2
0.082	A	150D823(1)100A(2)(3)(4)	0.5	2
0.10	A	150D104(1)100A(2)(3)(4)	0.5	2
0.12	A	150D124(1)100A(2)(3)(4)	0.5	2
0.15	A	150D154(1)100A(2)(3)(4)	0.5	2
0.18	A	150D184(1)100A(2)(3)(4)	0.5	2
0.22	A	150D224(1)100A(2)(3)(4)	0.5	2
0.27	A	150D274(1)100A(2)(3)(4)	0.5	2
0.33	A	150D334(1)100A(2)(3)(4)	0.5	2
0.39	A	150D394(1)100A(2)(3)(4)	0.5	2
0.47	A	150D474(1)100A(2)(3)(4)	0.5	2
0.56	A	150D564(1)100A(2)(3)(4)	0.5	2
0.68	B	150D684(1)100B(2)(3)(4)	0.5	2

Note

- Part number definitions:
 - For 10 % tolerance specify "X9"; for 20 % specify "X0"; for 5 % "X5" (special order)
 - Style number: 0 = no sleeve, 2 = insulated sleeve
 - Packaging options: B = bulk, T = tape and reel, G = ammo pack
 - Termination: E3 = 100 % tin, blank = SnPb



STANDARD RATINGS				
CAPACITANCE (μ F)	CASE CODE	PART NUMBER	MAX. DCL AT +25 °C (μ A)	MAX. DF AT +25 °C 120 Hz (%)
100 V_{DC} AT +85 °C, SURGE = 130 V; 67 V_{DC} AT +125 °C, SURGE = 86 V				
0.82	B	150D824(1)100B(2)(3)(4)	0.5	2
1.0	B	150D105(1)100B(2)(3)(4)	0.5	2
1.2	B	150D125(1)100B(2)(3)(4)	0.5	3
1.5	B	150D155(1)100B(2)(3)(4)	0.6	3
1.8	B	150D185(1)100B(2)(3)(4)	0.6	3
2.2	B	150D225(1)100B(2)(3)(4)	0.6	3
2.7	B	150D275(1)100B(2)(3)(4)	0.6	3
3.3	R	150D335(1)100R(2)(3)(4)	2.5	3
3.9	R	150D395(1)100R(2)(3)(4)	3.0	3
4.7	R	150D475(1)100R(2)(3)(4)	4.0	3
5.6	R	150D565(1)100R(2)(3)(4)	4.0	3
6.8	R	150D685(1)100R(2)(3)(4)	6.0	3
8.2	S	150D825(1)100S(2)(3)(4)	6.0	3
10	S	150D106(1)100S(2)(3)(4)	6.0	3
125 V_{DC} AT +85 °C, SURGE = 140 V; 82 V_{DC} AT +125 °C, SURGE = 94 V				
0.027	A	150D273(1)125A(2)(3)(4)	1.0	2
0.033	A	150D333(1)125A(2)(3)(4)	1.0	2
0.039	A	150D393(1)125A(2)(3)(4)	1.0	2
0.047	A	150D473(1)125A(2)(3)(4)	1.0	2
0.056	A	150D563(1)125A(2)(3)(4)	1.0	2
0.068	A	150D683(1)125A(2)(3)(4)	1.0	2
0.082	A	150D823(1)125A(2)(3)(4)	1.0	2
0.10	A	150D104(1)125A(2)(3)(4)	1.0	2
0.12	A	150D124(1)125A(2)(3)(4)	1.0	2
0.15	A	150D154(1)125A(2)(3)(4)	1.0	2
0.18	A	150D184(1)125A(2)(3)(4)	1.0	2
0.22	A	150D224(1)125A(2)(3)(4)	1.0	2
0.27	A	150D274(1)125A(2)(3)(4)	1.0	2
0.33	A	150D334(1)125A(2)(3)(4)	1.0	2
0.39	A	150D394(1)125A(2)(3)(4)	1.5	2
0.47	A	150D474(1)125A(2)(3)(4)	1.5	2
0.56	B	150D564(1)125B(2)(3)(4)	1.6	2
0.68	B	150D684(1)125B(2)(3)(4)	1.8	2
0.82	B	150D824(1)125B(2)(3)(4)	2.0	2
1.0	B	150D105(1)125B(2)(3)(4)	2.0	2
1.2	B	150D125(1)125B(2)(3)(4)	2.0	3
1.5	B	150D155(1)125B(2)(3)(4)	2.0	3
1.8	B	150D185(1)125B(2)(3)(4)	2.0	3
2.2	B	150D225(1)125B(2)(3)(4)	2.0	3

Note

- Part number definitions:
 - For 10 % tolerance specify "X9"; for 20 % specify "X0"; for 5 % "X5" (special order)
 - Style number: 0 = no sleeve, 2 = insulated sleeve
 - Packaging options: B = bulk, T = tape and reel, G = ammo pack
 - Termination: E3 = 100 % tin, blank = SnPb

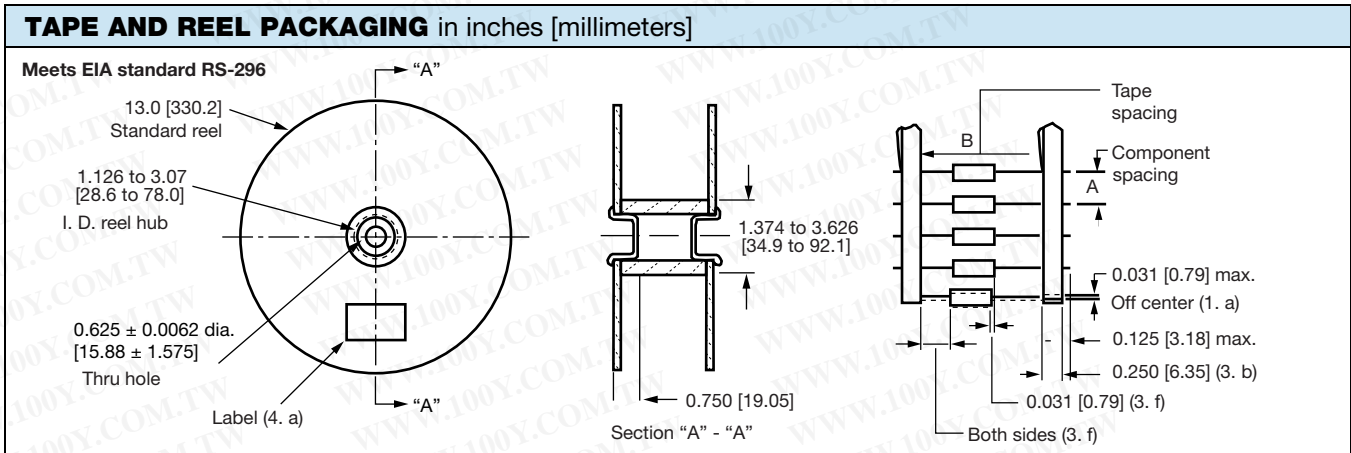

STANDARD PACKAGING QUANTITY AND DIMENSIONS in inches [millimeters]					
CASE CODE	COMPONENT SPACING A	TAPE AND REEL		AMMO PACK	
		TAPE SPACING B	UNITS PER REEL	TAPE SPACING B	UNITS PER BOX
A	0.200 ± 0.015 [5.08 ± 0.38]	2.500 ± 0.062 [63.5 ± 1.57]	1000	2.063 ± 0.073 [53 ± 2]	500
B	0.200 ± 0.015 [5.08 ± 0.38]	2.500 ± 0.062 [63.5 ± 1.57]	1000	2.063 ± 0.073 [53 ± 2]	500
R	0.400 ± 0.015 [10.16 ± 0.38]	2.875 ± 0.062 [73.03 ± 1.57]	500	2.063 ± 0.073 [53 ± 2]	250
S	0.400 ± 0.015 [10.16 ± 0.38]	2.875 ± 0.062 [73.03 ± 1.57]	500	2.063 ± 0.073 [53 ± 2]	250

STANDARD REEL PACKAGING INFORMATION

1. Component Leads

- a. Component leads shall not be bent beyond 0.047" [1.19 mm] maximum from their nominal position when measured from the leading edge of the component lead at the inside tape edge and at the lead egress from the component.
- b. The "C" dimension shall be governed by the overall length of the reel packaged component. The distance between flanges shall be 0.125" to 0.250" [3.18 mm to 6.35 mm] greater than the overall component length.

2. Orientation

All polarized components must be oriented to one direction. The cathode lead tape shall be a color and the anode lead tape shall be white.

3. Reeling

- a. Components on any reel shall not represent more than two date codes when date code identification is required.
- b. Component leads shall be positioned between pairs of 0.250" [6.35 mm] tape.
- c. The disposable reels have hubs and corrugated fibreboard flanges and core or equivalent.
- d. A minimum of 12.0" [304.8 mm] leader of tape shall be provided before the first and after the last component on the reel.
- e. 50 lb or 60 lb. Kraft paper must be wound between layer of components as far as necessary for component protection. Width of paper to be 0.062" to 0.250" [1.57 mm to 6.35 mm] less than the "C" dimension of the reel. Solid-electrolyte TANTALEX capacitors hermetically-sealed, axial-lead.

- f. A row of components must be centered between tapes ± 0.047" [1.19 mm]. In addition, individual components may deviate from center of component row ± 0.031" [0.79 mm].
- g. Staples shall not be used for splicing. Not more than 4 layers of tape shall be used in any splice area and no tape shall be offset from another by more than 0.031" [0.79 mm] non-cumulative. Tape splices shall overlap at least 6.0" [152.4 mm] for butt joints and at least 3.0" [76.2 mm] for lap joints and shall not be weaker than unspliced tape. Universal splicing clips may also be used.
- h. Quantity per reel shall be controlled so that tape components and cover shall not extend beyond the smallest dimension of the flange (either across flats or diameter). Once the quantity per reel for each part number has been established, future orders for that part number shall be packaged in that quantity. When order or release quantity is less than the established quantity, a standard commercial pack is to be used.
- i. A maximum of 0.25 % of the components per reel quantity may be missing without consecutive missing components.
- j. Adequate protection must be provided to prevent physical damage to both reel and components during shipment and storage.

4. Marking

Minimum reel and carton marking shall consist of the following: customer part number, purchase order no., quantity, package date, manufacturer's name, electrical value, date code, Vishay Sprague part number and country of origin.