

Notice for TAIYO YUDEN products

Please read this notice before using the TAIYO YUDEN products.

! REMINDERS

- Product information in this catalog is as of October 2011. All of the contents specified herein are subject to change without notice due to technical improvements, etc. Therefore, please check for the latest information carefully before practical application or usage of the Products.

Please note that Taiyo Yuden Co., Ltd. shall not be responsible for any defects in products or equipment incorporating such products, which are caused under the conditions other than those specified in this catalog or individual specification.

- Please contact Taiyo Yuden Co., Ltd. for further details of product specifications as the individual specification is available.
- Please conduct validation and verification of products in actual condition of mounting and operating environment before commercial shipment of the equipment.

- All electronic components or functional modules listed in this catalog are developed, designed and intended for use in general electronics equipment.(for AV, office automation, household, office supply, information service, telecommunications, (such as mobile phone or PC) etc.). Before incorporating the components or devices into any equipment in the field such as transportation,(automotive control, train control, ship control), transportation signal, disaster prevention, medical, public information network (telephone exchange, base station) etc. which may have direct influence to harm or injure a human body, please contact Taiyo Yuden Co., Ltd. for more detail in advance. Do not incorporate the products into any equipment in fields such as aerospace, aviation, nuclear control, submarine system, military, etc. where higher safety and reliability are especially required.

In addition, even electronic components or functional modules that are used for the general electronic equipment, if the equipment or the electric circuit require high safety or reliability function or performances, a sufficient reliability evaluation check for safety shall be performed before commercial shipment and moreover, due consideration to install a protective circuit is strongly recommended at customer's design stage.

- The contents of this catalog are applicable to the products which are purchased from our sales offices or distributors (so called "TAIYO YUDEN' s official sales channel").

It is only applicable to the products purchased from any of TAIYO YUDEN' s official sales channel.

- Please note that Taiyo Yuden Co., Ltd. shall have no responsibility for any controversies or disputes that may occur in connection with a third party's intellectual property rights and other related rights arising from your usage of products in this catalog. Taiyo Yuden Co., Ltd. grants no license for such rights.

- Caution for export

Certain items in this catalog may require specific procedures for export according to "Foreign Exchange and Foreign Trade Control Law" of Japan, "U.S. Export Administration Regulations", and other applicable regulations. Should you have any question or inquiry on this matter, please contact our sales staff.

勝特力材料 886-3-5753170
勝特力电子(上海) 86-21-34970699
勝特力电子(深圳) 86-755-83298787
[Http://www.100y.com.tw](http://www.100y.com.tw)

HIGH VALUE MULTILAYER CERAMIC CAPACITORS(HIGH DIELECTRIC TYPE)

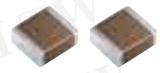

WAVE

REFLOW

FEATURES

- Improved higher density mounting. (042 to 105 type)
- Monolithic structure provides higher reliability.
- A wide range of capacitance values available in standard case sizes.
- The use of nickel as electrode material and plating processing improve the solderability and heat resistance characteristics. It also prevents migration and raises the level of reliability.
- Low equivalent series resistance(ESR) provides superior noise absorption characteristics.
- Compared to tantalum or aluminum electrolytic capacitors, multilayer ceramic capacitors offer a number of superior features, including:
Higher permissible ripple current values
Smaller case sizes with high rated voltage
Improved reliability due to higher insulation resistance and breakdown voltage.

APPLICATIONS

- Communication equipment
(cellular phone, wireless applications, etc.)
- General digital circuit
- Power supply bypass capacitors
Liquid crystal modules
Liquid crystal drive voltage lines
LSI, IC, converters(both for input and output)
- Smoothing capacitors
DC-DC converters (for both input and output)
Switching power supplies (secondary side)

PART NUMBER

J M K 3 1 6 △ B J 1 0 6 M L - T △

1 Rated voltage (VDC)	2 Series name	3 End termination	4 Dimension	5 Dimension tolerance [mm]	6 Temperature characteristics code	7 Nominal capacitance (pF)	8 Capacitance tolerance	9 Thickness (mm)	10 Special code	11 Packaging	12 Internal code																																																																																																																																										
A 4 J 6.3 L 10 E 16 T 25 G 35 U 50	M	K Plated	<table border="1"> <tr> <th>Type</th> <th>(inch)</th> <th>L×W [mm]</th> </tr> <tr> <td>042</td> <td>(01005)</td> <td>0.4×0.2</td> </tr> <tr> <td>063</td> <td>(0201)</td> <td>0.6×0.3</td> </tr> <tr> <td>105</td> <td>(0402)</td> <td>1.0×0.5</td> </tr> <tr> <td>107</td> <td>(0603)</td> <td>1.6×0.8</td> </tr> <tr> <td>212</td> <td>(0805)</td> <td>2.0×1.25</td> </tr> <tr> <td>316</td> <td>(1206)</td> <td>3.2×1.6</td> </tr> <tr> <td>325</td> <td>(1210)</td> <td>3.2×2.5</td> </tr> </table>	Type	(inch)	L×W [mm]	042	(01005)	0.4×0.2	063	(0201)	0.6×0.3	105	(0402)	1.0×0.5	107	(0603)	1.6×0.8	212	(0805)	2.0×1.25	316	(1206)	3.2×1.6	325	(1210)	3.2×2.5	<table border="1"> <tr> <th>Code</th> <th>Type</th> <th>L</th> <th>W</th> <th>T</th> </tr> <tr> <td>△</td> <td>ALL</td> <td>Standard</td> <td>Standard</td> <td>Standard</td> </tr> <tr> <td rowspan="6">A</td> <td>063</td> <td>0.6±0.05</td> <td>0.3±0.05</td> <td>0.3±0.05</td> </tr> <tr> <td>105</td> <td>1.0±0.1</td> <td>0.5±0.1</td> <td>0.5±0.1</td> </tr> <tr> <td>107</td> <td>1.6+0.15/-0.05</td> <td>0.8+0.15/-0.05</td> <td>0.8+0.15/-0.05</td> </tr> <tr> <td rowspan="3">212</td> <td rowspan="3">2.0+0.15/-0.05</td> <td rowspan="3">1.25+0.15/-0.05</td> <td>0.45±0.05</td> </tr> <tr> <td>0.85±0.1</td> </tr> <tr> <td>1.25+0.15/-0.05</td> </tr> <tr> <td>316</td> <td>3.2±0.2</td> <td>1.6±0.2</td> <td>0.85±0.1</td> </tr> <tr> <td rowspan="3">325</td> <td rowspan="3">3.2±0.3</td> <td rowspan="3">2.5±0.3</td> <td>1.6±0.2</td> </tr> <tr> <td>2.5±0.3</td> </tr> <tr> <td>2.5±0.3</td> </tr> <tr> <td rowspan="3">B</td> <td>105</td> <td>1.0+0.15/-0.05</td> <td>0.5+0.15/-0.05</td> <td>0.5+0.15/-0.05</td> </tr> <tr> <td rowspan="2">107</td> <td rowspan="2">1.6+0.2/-0</td> <td rowspan="2">0.8+0.2/-0</td> <td>0.45±0.05</td> </tr> <tr> <td>0.8+0.2/-0</td> </tr> <tr> <td>212</td> <td>2.0+0.2/-0</td> <td>1.25+0.2/-0</td> <td>0.85±0.1</td> </tr> <tr> <td></td> <td></td> <td></td> <td>1.25+0.2/-0</td> <td></td> </tr> </table>	Code	Type	L	W	T	△	ALL	Standard	Standard	Standard	A	063	0.6±0.05	0.3±0.05	0.3±0.05	105	1.0±0.1	0.5±0.1	0.5±0.1	107	1.6+0.15/-0.05	0.8+0.15/-0.05	0.8+0.15/-0.05	212	2.0+0.15/-0.05	1.25+0.15/-0.05	0.45±0.05	0.85±0.1	1.25+0.15/-0.05	316	3.2±0.2	1.6±0.2	0.85±0.1	325	3.2±0.3	2.5±0.3	1.6±0.2	2.5±0.3	2.5±0.3	B	105	1.0+0.15/-0.05	0.5+0.15/-0.05	0.5+0.15/-0.05	107	1.6+0.2/-0	0.8+0.2/-0	0.45±0.05	0.8+0.2/-0	212	2.0+0.2/-0	1.25+0.2/-0	0.85±0.1				1.25+0.2/-0		<table border="1"> <tr> <td>BJ</td> <td>B</td> </tr> <tr> <td></td> <td>X5R</td> </tr> <tr> <td>B7</td> <td>X7R</td> </tr> <tr> <td>△F</td> <td>F</td> </tr> <tr> <td></td> <td>Y5V</td> </tr> </table> <p>△=Blank space</p>	BJ	B		X5R	B7	X7R	△F	F		Y5V	<table border="1"> <tr> <td>example</td> <td></td> </tr> <tr> <td>473</td> <td>47,000</td> </tr> <tr> <td>105</td> <td>1,000,000</td> </tr> </table>	example		473	47,000	105	1,000,000	<table border="1"> <tr> <td>K</td> <td>±10%</td> </tr> <tr> <td>M</td> <td>±20%</td> </tr> <tr> <td>Z</td> <td>+80% -20%</td> </tr> </table>	K	±10%	M	±20%	Z	+80% -20%	<table border="1"> <tr> <td>C</td> <td>0.2</td> </tr> <tr> <td>P</td> <td>0.3</td> </tr> <tr> <td>V</td> <td>0.5</td> </tr> <tr> <td>K</td> <td>0.45</td> </tr> <tr> <td>A</td> <td>0.8</td> </tr> <tr> <td>D</td> <td>0.85</td> </tr> <tr> <td>G</td> <td>1.25</td> </tr> <tr> <td>L</td> <td>1.6</td> </tr> <tr> <td>N</td> <td>1.9</td> </tr> <tr> <td>Y</td> <td>2.0max</td> </tr> <tr> <td>M</td> <td>2.5</td> </tr> </table>	C	0.2	P	0.3	V	0.5	K	0.45	A	0.8	D	0.85	G	1.25	L	1.6	N	1.9	Y	2.0max	M	2.5	- Standard	<table border="1"> <tr> <td>F</td> <td>φ178mm Taping (2mm pitch)</td> </tr> <tr> <td>W</td> <td>φ178mm Taping (1mm pitch, 042 Type)</td> </tr> <tr> <td>T</td> <td>φ178mm Taping (4mm pitch) All types</td> </tr> <tr> <td>P</td> <td>φ178mm Taping (4mm pitch, 1000pcs/reel) 1210Type Thickness : M</td> </tr> </table>	F	φ178mm Taping (2mm pitch)	W	φ178mm Taping (1mm pitch, 042 Type)	T	φ178mm Taping (4mm pitch) All types	P	φ178mm Taping (4mm pitch, 1000pcs/reel) 1210Type Thickness : M	<table border="1"> <tr> <td>△</td> <td>Standard</td> </tr> <tr> <td>△</td> <td>=Blank space</td> </tr> </table>	△	Standard	△	=Blank space
Type	(inch)	L×W [mm]																																																																																																																																																			
042	(01005)	0.4×0.2																																																																																																																																																			
063	(0201)	0.6×0.3																																																																																																																																																			
105	(0402)	1.0×0.5																																																																																																																																																			
107	(0603)	1.6×0.8																																																																																																																																																			
212	(0805)	2.0×1.25																																																																																																																																																			
316	(1206)	3.2×1.6																																																																																																																																																			
325	(1210)	3.2×2.5																																																																																																																																																			
Code	Type	L	W	T																																																																																																																																																	
△	ALL	Standard	Standard	Standard																																																																																																																																																	
A	063	0.6±0.05	0.3±0.05	0.3±0.05																																																																																																																																																	
	105	1.0±0.1	0.5±0.1	0.5±0.1																																																																																																																																																	
	107	1.6+0.15/-0.05	0.8+0.15/-0.05	0.8+0.15/-0.05																																																																																																																																																	
	212	2.0+0.15/-0.05	1.25+0.15/-0.05	0.45±0.05																																																																																																																																																	
				0.85±0.1																																																																																																																																																	
				1.25+0.15/-0.05																																																																																																																																																	
316	3.2±0.2	1.6±0.2	0.85±0.1																																																																																																																																																		
325	3.2±0.3	2.5±0.3	1.6±0.2																																																																																																																																																		
			2.5±0.3																																																																																																																																																		
			2.5±0.3																																																																																																																																																		
B	105	1.0+0.15/-0.05	0.5+0.15/-0.05	0.5+0.15/-0.05																																																																																																																																																	
	107	1.6+0.2/-0	0.8+0.2/-0	0.45±0.05																																																																																																																																																	
				0.8+0.2/-0																																																																																																																																																	
212	2.0+0.2/-0	1.25+0.2/-0	0.85±0.1																																																																																																																																																		
			1.25+0.2/-0																																																																																																																																																		
BJ	B																																																																																																																																																				
	X5R																																																																																																																																																				
B7	X7R																																																																																																																																																				
△F	F																																																																																																																																																				
	Y5V																																																																																																																																																				
example																																																																																																																																																					
473	47,000																																																																																																																																																				
105	1,000,000																																																																																																																																																				
K	±10%																																																																																																																																																				
M	±20%																																																																																																																																																				
Z	+80% -20%																																																																																																																																																				
C	0.2																																																																																																																																																				
P	0.3																																																																																																																																																				
V	0.5																																																																																																																																																				
K	0.45																																																																																																																																																				
A	0.8																																																																																																																																																				
D	0.85																																																																																																																																																				
G	1.25																																																																																																																																																				
L	1.6																																																																																																																																																				
N	1.9																																																																																																																																																				
Y	2.0max																																																																																																																																																				
M	2.5																																																																																																																																																				
F	φ178mm Taping (2mm pitch)																																																																																																																																																				
W	φ178mm Taping (1mm pitch, 042 Type)																																																																																																																																																				
T	φ178mm Taping (4mm pitch) All types																																																																																																																																																				
P	φ178mm Taping (4mm pitch, 1000pcs/reel) 1210Type Thickness : M																																																																																																																																																				
△	Standard																																																																																																																																																				
△	=Blank space																																																																																																																																																				

5 Dimension tolerance [mm]				
Code	Type	L	W	T
△	ALL	Standard	Standard	Standard
A	063	0.6±0.05	0.3±0.05	0.3±0.05
	105	1.0±0.1	0.5±0.1	0.5±0.1
	107	1.6+0.15/-0.05	0.8+0.15/-0.05	0.8+0.15/-0.05
	212	2.0+0.15/-0.05	1.25+0.15/-0.05	0.45±0.05
				0.85±0.1
				1.25+0.15/-0.05
316	3.2±0.2	1.6±0.2	0.85±0.1	
325	3.2±0.3	2.5±0.3	1.6±0.2	
			2.5±0.3	
			2.5±0.3	
B	105	1.0+0.15/-0.05	0.5+0.15/-0.05	0.5+0.15/-0.05
	107	1.6+0.2/-0	0.8+0.2/-0	0.45±0.05
				0.8+0.2/-0
212	2.0+0.2/-0	1.25+0.2/-0	0.85±0.1	
			1.25+0.2/-0	

△=Blank space

勝特力材料 886-3-5753170
 勝特力电子(上海) 86-21-34970699
 勝特力电子(深圳) 86-755-83298787
[Http://www.100y.com.tw](http://www.100y.com.tw)

STANDARD EXTERNAL DIMENSIONS/STANDARD QUANTITY

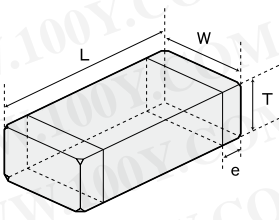

Type	Dimension [mm]				e	Standard quantity [pcs]	
	L	W	T			Paper tape	Embossed tape
□MK042 (01005 inch)	0.4±0.02	0.2±0.02	0.2±0.02	C	0.1±0.03	-	40000
□MK063 (0201 inch)	0.6±0.03	0.3±0.03	0.3±0.03	P	0.15±0.05	15000	-
□MK105 (0402 inch)	1.0±0.05	0.5±0.05	0.2±0.02	C	0.25±0.10	20000	-
			0.3±0.03	P		15000	-
			0.5±0.05	V		10000	-
□MK107 (0603 inch)	1.6±0.10	0.8±0.10	0.45±0.05	K	0.35±0.25	4000	-
			0.8±0.10	A			-
			0.45±0.05	K			-
□MK212 (0805 inch)	2.0±0.10	1.25±0.10	0.85±0.10	D	0.5±0.25	4000	-
			1.25±0.10	G			-
			1.25±0.10	G			3000
□MK316 (1206 inch)	3.2±0.15	1.6±0.15	0.85±0.10	D	0.5+0.35/-0.25	4000	-
			1.25±0.10	G			3000
			1.6±0.20	L			2000
			0.85±0.10	D			-
□MK325 (1210 inch)	3.2±0.30	2.5±0.20	1.9±0.20	N	0.6±0.3	-	2000
			1.9+0.1/-0.2	Y			-
			2.5±0.20	M			-
			2.5±0.20	M			500(T), 1000(P)

* This catalog contains the typical specification only due to the limitation of space. When you consider the purchase of our products, please check our specification. For details of each product (characteristics graph, reliability information, precautions for use, and so on), see our Web site (<http://www.ty-top.com/>) or CD catalogs.

REPRESENTATIVE PART NUMBERS

●042TYPE(01005 case size)

[Temperature Characteristic BJ:B/X5R] ·0.2mm thickness(C)

Rated voltage	Part number 1	Part number 2	Temp. char.	Capacitance (pF)	Capacitance tolerance	tan δ (%)	Thickness (mm)	Soldering R:Reflow W:Wave	HALT	Internal code (P/N 1)	Note
									% Rated voltage		
10V	LMK042 BJ101□C		B/X5R ^{*1}	100	±10, ±20	5	0.2±0.02	R	200%		
	LMK042 BJ151□C		B/X5R ^{*1}	150	±10, ±20	5	0.2±0.02	R	200%		
	LMK042 BJ221□C		B/X5R ^{*1}	220	±10, ±20	5	0.2±0.02	R	200%		
	LMK042 BJ331□C		B/X5R ^{*1}	330	±10, ±20	5	0.2±0.02	R	200%		
	LMK042 BJ471□C		B/X5R ^{*1}	470	±10, ±20	5	0.2±0.02	R	200%		
	LMK042 BJ681□C		B/X5R ^{*1}	680	±10, ±20	5	0.2±0.02	R	200%		
	LMK042 BJ102□C		B/X5R ^{*1}	1000	±10, ±20	5	0.2±0.02	R	200%		
	LMK042 BJ152□C		X5R	1500	±10, ±20	10	0.2±0.02	R	150%		
	LMK042 BJ222□C		X5R	2200	±10, ±20	10	0.2±0.02	R	150%		
	LMK042 BJ332□C		X5R	3300	±10, ±20	10	0.2±0.02	R	150%		
	LMK042 BJ472□C		X5R	4700	±10, ±20	10	0.2±0.02	R	150%		
	LMK042 BJ682□C		X5R	6800	±10, ±20	10	0.2±0.02	R	150%		
6.3V	JMK042 BJ103□C		X5R	10000	±10, ±20	10	0.2±0.02	R	150%		
	JMK042 BJ152□C		B/X5R ^{*1}	1500	±10, ±20	10	0.2±0.02	R	150%		
	JMK042 BJ222□C		B/X5R ^{*1}	2200	±10, ±20	10	0.2±0.02	R	150%		
	JMK042 BJ332□C		B/X5R ^{*1}	3300	±10, ±20	10	0.2±0.02	R	150%		
	JMK042 BJ472□C		B/X5R ^{*1}	4700	±10, ±20	10	0.2±0.02	R	150%		
	JMK042 BJ682□C		B/X5R ^{*1}	6800	±10, ±20	10	0.2±0.02	R	150%		
4V	JMK042 BJ103□C		B/X5R ^{*1}	10000	±10, ±20	10	0.2±0.02	R	150%		
	JMK042 BJ223□C		X5R	22000	±10, ±20	10	0.2±0.02	R	150%		
	AMK042 BJ473MC		X5R	47000	±20	10	0.2±0.02	R	150%		
	AMK042 BJ104MC		X5R	100000	±20	10	0.2±0.02	R	150%		

Capacitance tolerance code is applied to □ of part number. *1 We may provide X7S/X7R for some items according to the individual specification.

[Temperature Characteristic B7 : X7R] ·0.2mm thickness(C)

Rated voltage	Part number 1	Part number 2	Temp. char.	Capacitance (pF)	Capacitance tolerance	tan δ (%)	Thickness (mm)	Soldering R:Reflow W:Wave	HALT	Internal code (P/N 1)	Note
									% Rated voltage		
10V	LMK042 B7101□C		X7R	100	±10, ±20	5	0.2±0.02	R	200%		
	LMK042 B7151□C		X7R	150	±10, ±20	5	0.2±0.02	R	200%		
	LMK042 B7221□C		X7R	220	±10, ±20	5	0.2±0.02	R	200%		
	LMK042 B7331□C		X7R	330	±10, ±20	5	0.2±0.02	R	200%		
	LMK042 B7471□C		X7R	470	±10, ±20	5	0.2±0.02	R	200%		
	LMK042 B7681□C		X7R	680	±10, ±20	5	0.2±0.02	R	200%		
	LMK042 B7102□C		X7R	1000	±10, ±20	5	0.2±0.02	R	200%		

Capacitance tolerance code is applied to □ of part number.

●063TYPE(0201 case size)

[Temperature Characteristic BJ:B/X5R] ·0.3mm thickness(P)

Rated voltage	Part number 1	Part number 2	Temp. char.	Capacitance (pF)	Capacitance tolerance	tan δ (%)	Thickness (mm)	Soldering R:Reflow W:Wave	HALT	Internal code (P/N 1)	Note	
									% Rated voltage			
25V	TMK063 BJ101□P		B/X5R ^{*1}	100	±10, ±20	3.5	0.3±0.03	R	200%			
	TMK063 BJ151□P		B/X5R ^{*1}	150	±10, ±20	3.5	0.3±0.03	R	200%			
	TMK063 BJ221□P		B/X5R ^{*1}	220	±10, ±20	3.5	0.3±0.03	R	200%			
	TMK063 BJ331□P		B/X5R ^{*1}	330	±10, ±20	3.5	0.3±0.03	R	200%			
	TMK063 BJ471□P		B/X5R ^{*1}	470	±10, ±20	3.5	0.3±0.03	R	200%			
	TMK063 BJ681□P		B/X5R ^{*1}	680	±10, ±20	3.5	0.3±0.03	R	200%			
	TMK063 BJ102□P		B/X5R ^{*1}	1000	±10, ±20	3.5	0.3±0.03	R	200%			
	TMK063 BJ152□P		B/X5R	1500	±10, ±20	5	0.3±0.03	R	200%			
	TMK063 BJ222□P		B/X5R	2200	±10, ±20	5	0.3±0.03	R	200%			
	TMK063 BJ332□P		B/X5R	3300	±10, ±20	5	0.3±0.03	R	200%			
	TMK063 BJ472□P		B/X5R	4700	±10, ±20	5	0.3±0.03	R	200%			
	TMK063 BJ682□P		B/X5R	6800	±10, ±20	5	0.3±0.03	R	200%			
	TMK063 BJ103□P		B/X5R	10000	±10, ±20	5	0.3±0.03	R	200%			
		TMK063 BJ104□P		B/X5R	10000	±10, ±20	5	0.3±0.03	R	200%		
	16V	EMK063 BJ152□P		B/X5R ^{*1}	1500	±10, ±20	5	0.3±0.03	R	200%		
EMK063 BJ222□P			B/X5R ^{*1}	2200	±10, ±20	5	0.3±0.03	R	200%			
EMK063 BJ332□P			B/X5R ^{*1}	3300	±10, ±20	5	0.3±0.03	R	200%			
EMK063 BJ472□P			B/X5R ^{*1}	4700	±10, ±20	5	0.3±0.03	R	200%			
EMK063 BJ682□P			B/X5R ^{*1}	6800	±10, ±20	5	0.3±0.03	R	200%			
EMK063 BJ103□P			B/X5R ^{*1}	10000	±10, ±20	5	0.3±0.03	R	200%			
10V	EMK063 BJ104□P		X5R	100000	±10, ±20	10	0.3±0.03	R	150%			
	LMK063 BJ223□P		B/X5R	22000	±10, ±20	7.5	0.3±0.03	R	150%			
	LMK063 BJ333□P		X5R	33000	±10, ±20	7.5	0.3±0.03	R	150%			
	LMK063 BJ473□P		X5R	47000	±10, ±20	7.5	0.3±0.03	R	150%			
	LMK063 BJ683□P		X5R	68000	±10, ±20	10	0.3±0.03	R	150%			
	LMK063 BJ104□P		X5R	100000	±10, ±20	10	0.3±0.03	R	150%			
6.3V	JMK063 BJ224□P		X5R	220000	±10, ±20	10	0.3±0.03	R	150%			
	JMK063 BJ333□P		X5R	33000	±10, ±20	7.5	0.3±0.03	R	150%			
	JMK063 BJ473□P		X5R	47000	±10, ±20	7.5	0.3±0.03	R	150%			
	JMK063 BJ683□P		X5R	68000	±10, ±20	10	0.3±0.03	R	150%			
	JMK063 BJ104□P		X5R	100000	±10, ±20	10	0.3±0.03	R	150%			
	JMK063 BJ224□P		X5R	220000	±10, ±20	10	0.3±0.03	R	150%			
4V	AMK063 BJ224□P		X5R	220000	±10, ±20	10	0.3±0.03	R	150%			
	AMK063 BJ334MP		X5R	330000	±20	10	0.3±0.03	R	150%		*2	
	AMK063 BJ474MP		X5R	470000	±20	10	0.3±0.03	R	150%			
	AMK063ABJ105MP		X5R	1000000	±20	10	0.3±0.05	R	150%			

Capacitance tolerance code is applied to □ of part number. *1 We may provide X7R for some items according to the individual specification. *2 The exchange of individual specification is necessary depending on the application and circuit condition. Please contact Taiyo Yuden sales channels.

* This catalog contains the typical specification only due to the limitation of space. When you consider the purchase of our products, please check our specification. For details of each product (characteristics graph, reliability information, precautions for use, and so on), see our Web site (<http://www.ty-top.com/>) or CD catalogs.

REPRESENTATIVE PART NUMBERS

[Temperature Characteristic B7 : X7R]
·0.3mm thickness(P)

Rated voltage	Part number 1	Part number 2	Temp. char.	Capacitance (pF)	Capacitance tolerance	tanδ [%]	Thickness (mm)	Soldering R:Reflow W:Wave	HALT % Rated voltage	Internal code (P/N 1)	Note
25V	TMK063 B7101□P		X7R	100	±10, ±20	3.5	0.3±0.03	R	200%		
	TMK063 B7151□P		X7R	150	±10, ±20	3.5	0.3±0.03	R	200%		
	TMK063 B7221□P		X7R	220	±10, ±20	3.5	0.3±0.03	R	200%		
	TMK063 B7331□P		X7R	330	±10, ±20	3.5	0.3±0.03	R	200%		
	TMK063 B7471□P		X7R	470	±10, ±20	3.5	0.3±0.03	R	200%		
	TMK063 B7681□P		X7R	680	±10, ±20	3.5	0.3±0.03	R	200%		
16V	EMK063 B7102□P		X7R	1000	±10, ±20	3.5	0.3±0.03	R	200%		
	EMK063 B7152□P		X7R	1500	±10, ±20	5	0.3±0.03	R	200%		
	EMK063 B7222□P		X7R	2200	±10, ±20	5	0.3±0.03	R	200%		
	EMK063 B7332□P		X7R	3300	±10, ±20	5	0.3±0.03	R	200%		
	EMK063 B7472□P		X7R	4700	±10, ±20	5	0.3±0.03	R	200%		
	EMK063 B7682□P		X7R	6800	±10, ±20	5	0.3±0.03	R	200%		
	EMK063 B7103□P		X7R	10000	±10, ±20	5	0.3±0.03	R	200%		

Capacitance tolerance code is applied to □ of part number.

●105TYPE (0402 case size)

[Temperature Characteristic BJ:B/X5R]
·0.5mm thickness(V)

Rated voltage	Part number 1	Part number 2	Temp. char.	Capacitance (pF)	Capacitance tolerance	tanδ [%]	Thickness (mm)	Soldering R:Reflow W:Wave	HALT % Rated voltage	Internal code (P/N 1)	Note	
50V	UMK105 BJ221□V		B/X5R ⁻¹	220	±10, ±20	2.5	0.5±0.05	R	200%			
	UMK105 BJ331□V		B/X5R ⁻¹	330	±10, ±20	2.5	0.5±0.05	R	200%			
	UMK105 BJ471□V		B/X5R ⁻¹	470	±10, ±20	2.5	0.5±0.05	R	200%			
	UMK105 BJ681□V		B/X5R ⁻¹	680	±10, ±20	2.5	0.5±0.05	R	200%			
	UMK105 BJ102□V		B/X5R ⁻¹	1000	±10, ±20	2.5	0.5±0.05	R	200%			
	UMK105 BJ152□V		B/X5R ⁻¹	1500	±10, ±20	2.5	0.5±0.05	R	200%			
	UMK105 BJ222□V		B/X5R ⁻¹	2200	±10, ±20	2.5	0.5±0.05	R	200%			
	UMK105 BJ332□V		B/X5R ⁻¹	3300	±10, ±20	2.5	0.5±0.05	R	200%			
	UMK105 BJ472□V		B/X5R ⁻¹	4700	±10, ±20	2.5	0.5±0.05	R	200%			
35V	UMK105 BJ682□V		B/X5R ⁻¹	6800	±10, ±20	2.5	0.5±0.05	R	150%			
	UMK105 BJ103□V		B/X5R ⁻¹	10000	±10, ±20	3.5	0.5±0.05	R	200%			
	GMK105 BJ104□V		B/X5R	100000	±10, ±20	5	0.5±0.05	R	150%			
	25V	TMK105 BJ153□V		B/X5R ⁻¹	15000	±10, ±20	3.5	0.5±0.05	R	200%		
		TMK105 BJ223□V		B/X5R ⁻¹	22000	±10, ±20	3.5	0.5±0.05	R	200%		
		TMK105 BJ333□V		B/X5R ⁻¹	33000	±10, ±20	3.5	0.5±0.05	R	150%		
		TMK105 BJ473□V		B/X5R ⁻¹	47000	±10, ±20	3.5	0.5±0.05	R	150%		
		TMK105 BJ104□V		B/X5R	100000	±10, ±20	5	0.5±0.05	R	150%		
	TMK105 BJ105□V		X5R	1000000	±10, ±20	10	0.5±0.05	R	150%			
16V	EMK105 BJ153□V		B/X5R ⁻¹	15000	±10, ±20	3.5	0.5±0.05	R	200%			
	EMK105 BJ223□V		B/X5R ⁻¹	22000	±10, ±20	3.5	0.5±0.05	R	200%			
	EMK105 BJ333□V		B/X5R ⁻¹	33000	±10, ±20	3.5	0.5±0.05	R	200%			
	EMK105 BJ473□V		B/X5R ⁻¹	47000	±10, ±20	3.5	0.5±0.05	R	200%			
	EMK105 BJ683□V		B/X5R	68000	±10, ±20	5	0.5±0.05	R	200%			
	EMK105 BJ104□V		B/X5R ⁻¹	100000	±10, ±20	5	0.5±0.05	R	150%			
	EMK105 BJ224□V		B/X5R	220000	±10, ±20	5	0.5±0.05	R	150%			
	EMK105 BJ105□V		X5R	1000000	±10, ±20	10	0.5±0.05	R	150%			
	10V	LMK105 BJ104□V		B/X5R	100000	±10, ±20	5	0.5±0.05	R	200%		
LMK105 BJ224□V			B/X5R	220000	±10, ±20	5	0.5±0.05	R	150%			
LMK105 BJ474□V			X5R	470000	±10, ±20	10	0.5±0.05	R	150%			
LMK105 BJ105□V			X5R	1000000	±10, ±20	10	0.5±0.05	R	150%			
LMK105 BJ225MV			X5R	2200000	±20	10	0.5±0.05	R	150%			
6.3V	JMK105 BJ224□V		B/X5R	220000	±10, ±20	5	0.5±0.05	R	150%			
	JMK105 BJ474□V		X5R	470000	±10, ±20	10	0.5±0.05	R	150%			
	JMK105 BJ105□V		X5R	1000000	±10, ±20	10	0.5±0.05	R	150%			
	JMK105 BJ225MV		X5R	2200000	±20	10	0.5±0.05	R	150%			
	JMK105 BJ475MV	JMK105BBJ475MV	X5R	4700000	±20	10	0.5+0.15/-0.05	R	150%	D		
4V	AMK105 BJ335MV		X5R	3300000	±20	10	0.5±0.05	R	150%		*2	
	AMK105 BJ475MV	AMK105ABJ475MV	X5R	4700000	±20	10	0.5±0.1	R	150%			

Capacitance tolerance code is applied to □ of part number.

*1 We may provide X7R for some items according to the individual specification.

*2 The exchange of individual specification is necessary depending on the application and circuit condition. Please contact Taiyo Yuden sales channels.

勝特力材料 886-3-5753170
 勝特力电子(上海) 86-21-34970699
 勝特力电子(深圳) 86-755-83298787
[Http://www.100y.com.tw](http://www.100y.com.tw)

REPRESENTATIVE PART NUMBERS

• 0.3mm thickness (P)

Rated voltage	Part number 1	Part number 2	Temp. char.	Capacitance [pF]	Capacitance tolerance	tan δ (%)	Thickness (mm)	Soldering R:Reflow W:Wave	HALT	Internal code (P/N 1)	Note
									% Rated voltage		
25V	TMK105 BJ103□P		B/X5R	10000	±10, ±20	5	0.3±0.03	R	150%		
	TMK105 BJ104□P		X5R	100000	±10, ±20	10	0.3±0.03	R	150%		
	TMK105 BJ224□P		X5R	220000	±10, ±20	10	0.3±0.03	R	150%		
	TMK105 BJ474□P		X5R	470000	±10, ±20	10	0.3±0.03	R	150%		
16V	EMK105 BJ474□P		X5R	470000	±10, ±20	10	0.3±0.03	R	150%		
6.3V	JMK105 BJ105□P		X5R	1000000	±10, ±20	10	0.3±0.03	R	150%		

• 0.2mm thickness (C)

Rated voltage	Part number 1	Part number 2	Temp. char.	Capacitance [pF]	Capacitance tolerance	tan δ (%)	Thickness (mm)	Soldering R:Reflow W:Wave	HALT	Internal code (P/N 1)	Note
									% Rated voltage		
10V	LMK105 BJ104□C		X5R	100000	±10, ±20	10	0.2±0.02	R	150%		
6.3V	JMK105 BJ224□C		X5R	220000	±10, ±20	10	0.2±0.02	R	150%		
	JMK105 BJ474□C		X5R	470000	±10, ±20	10	0.2±0.02	R	150%		

Capacitance tolerance code is applied to □ of part number.

[Temperature Characteristic B7:X7R]

• 0.5mm thickness (V)

Rated voltage	Part number 1	Part number 2	Temp. char.	Capacitance [pF]	Capacitance tolerance	tan δ (%)	Thickness (mm)	Soldering R:Reflow W:Wave	HALT	Internal code (P/N 1)	Note
									% Rated voltage		
50V	UMK105 B7221□V		X7R	220	±10, ±20	2.5	0.5±0.05	R	200%		
	UMK105 B7331□V		X7R	330	±10, ±20	2.5	0.5±0.05	R	200%		
	UMK105 B7471□V		X7R	470	±10, ±20	2.5	0.5±0.05	R	200%		
	UMK105 B7681□V		X7R	680	±10, ±20	2.5	0.5±0.05	R	200%		
	UMK105 B7102□V		X7R	1000	±10, ±20	2.5	0.5±0.05	R	200%		
	UMK105 B7152□V		X7R	1500	±10, ±20	2.5	0.5±0.05	R	200%		
	UMK105 B7222□V		X7R	2200	±10, ±20	2.5	0.5±0.05	R	200%		
	UMK105 B7332□V		X7R	3300	±10, ±20	2.5	0.5±0.05	R	200%		
	UMK105 B7472□V		X7R	4700	±10, ±20	2.5	0.5±0.05	R	150%		
	UMK105 B7682□V		X7R	6800	±10, ±20	2.5	0.5±0.05	R	150%		
25V	UMK105 B7103□V		X7R	10000	±10, ±20	3.5	0.5±0.05	R	150%		
	TMK105 B7152□V		X7R	1500	±10, ±20	2.5	0.5±0.05	R	200%		
	TMK105 B7222□V		X7R	2200	±10, ±20	2.5	0.5±0.05	R	200%		
	TMK105 B7332□V		X7R	3300	±10, ±20	2.5	0.5±0.05	R	200%		
	TMK105 B7472□V		X7R	4700	±10, ±20	2.5	0.5±0.05	R	200%		
	TMK105 B7682□V		X7R	6800	±10, ±20	2.5	0.5±0.05	R	200%		
16V	TMK105 B7103□V		X7R	10000	±10, ±20	3.5	0.5±0.05	R	200%		
	TMK105 B7224□V		X7R	220000	±10, ±20	10	0.5±0.05	R	150%	R	
	EMK105 B7223□V		X7R	22000	±10, ±20	3.5	0.5±0.05	R	200%		
	EMK105 B7473□V		X7R	47000	±10, ±20	3.5	0.5±0.05	R	200%		
	EMK105 B7104□V		X7R	100000	±10, ±20	5	0.5±0.05	R	150%		
10V	EMK105 B7224□V		X7R	220000	±10, ±20	10	0.5±0.05	R	150%	R	
	LMK105 B7223□V		X7R	22000	±10, ±20	3.5	0.5±0.05	R	200%		
	LMK105 B7473□V		X7R	47000	±10, ±20	3.5	0.5±0.05	R	200%		
	LMK105 B7104□V		X7R	100000	±10, ±20	5	0.5±0.05	R	150%		
	LMK105 B7224□V		X7R	220000	±10, ±20	10	0.5±0.05	R	150%	R	
6.3V	LMK105 B7474□V		X7R	470000	±10, ±20	10	0.5±0.05	R	150%		
	JMK105 B7224□V		X7R	220000	±10, ±20	5	0.5±0.05	R	150%		

Capacitance tolerance code is applied to □ of part number.

[Temperature Characteristic F:Y5V]

• 0.5mm thickness (V)

Rated voltage	Part number 1	Part number 2	Temp. char.	Capacitance [pF]	Capacitance tolerance	tan δ (%)	Thickness (mm)	Soldering R:Reflow W:Wave	HALT	Internal code (P/N 1)	Note
									% Rated voltage		
50V	UMK105 F103ZV		F/Y5V	10000	+80/-20	5	0.5±0.05	R	200%		
25V	TMK105 F223ZV		F/Y5V	22000	+80/-20	5	0.5±0.05	R	200%		
16V	EMK105 F473ZV		F/Y5V	47000	+80/-20	7	0.5±0.05	R	200%		
	EMK105 F104ZV		F/Y5V	100000	+80/-20	9	0.5±0.05	R	200%		
10V	LMK105 F224ZV		F/Y5V	220000	+80/-20	11	0.5±0.05	R	200%		
6.3V	JMK105 F474ZV		F/Y5V	470000	+80/-20	12.5	0.5±0.05	R	200%		
	JMK105 F105ZV		F/Y5V	1000000	+80/-20	20	0.5±0.05	R	150%		

勝特力材料 886-3-5753170
胜特力电子(上海) 86-21-34970699
胜特力电子(深圳) 86-755-83298787
[Http://www.100y.com.tw](http://www.100y.com.tw)

* This catalog contains the typical specification only due to the limitation of space. When you consider the purchase of our products, please check our specification. For details of each product (characteristics graph, reliability information, precautions for use, and so on), see our Web site (<http://www.ty-top.com/>) or CD catalogs.

REPRESENTATIVE PART NUMBERS

107TYPE

[Temperature Characteristic BJ:B/X5R]
 •0.8mm thickness(A)

Rated voltage	Part number 1	Part number 2	Temp. char.	Capacitance (μF)	Capacitance tolerance (%)	tan δ (%)	Thickness (mm)	Soldering R:Reflow W:Wave	HALT	Internal code (P/N 1)	Note
									% Rated voltage		
50V	UMK107 BJ474□A	UMK107ABJ474□A	X5R	0.47	±10, ±20	10	0.8+0.15/-0.05	R	150%	D	
	UMK107 BJ105□A		X5R	1	±10, ±20	10	0.8±0.1	R	150%		
35V	GMK107 BJ105□A		B/X5R	1	±10, ±20	5	0.8±0.1	R	150%		
25V	TMK107 BJ224□A		B/X5R	0.22	±10, ±20	3.5	0.8±0.1	R/W	200%		
	TMK107 BJ474□A		B/X5R	0.47	±10, ±20	3.5	0.8±0.1	R	150%		
	TMK107 BJ105□A		B/X5R	1	±10, ±20	5	0.8±0.1	R	150%		
16V	TMK107 BJ225□A	TMK107ABJ225□A	X5R	2.2	±10, ±20	10	0.8+0.15/-0.05	R	150%	D	
	EMK107 BJ224□A		B/X5R ^{*1}	0.22	±10, ±20	3.5	0.8±0.1	R/W	200%		
	EMK107 BJ474□A		B/X5R ^{*1}	0.47	±10, ±20	3.5	0.8±0.1	R	200%		
	EMK107 BJ105□A		B/X5R ^{*1}	1	±10, ±20	5	0.8±0.1	R	150%		
	EMK107 BJ225□A		B/X5R	2.2	±10, ±20	10	0.8±0.1	R	150%		
	EMK107 BJ475□A	EMK107ABJ475□A	X5R	4.7	±10, ±20	10	0.8+0.15/-0.05	R	150%	D	
10V	LMK107 BJ224□A		B/X5R ^{*1}	0.22	±10, ±20	3.5	0.8±0.1	R/W	200%		
	LMK107 BJ474□A		B/X5R ^{*1}	0.47	±10, ±20	3.5	0.8±0.1	R	200%		
	LMK107 BJ105□A		B/X5R ^{*1}	1	±10, ±20	5	0.8±0.1	R	200%		
	LMK107 BJ225□A		B/X5R	2.2	±10, ±20	10	0.8±0.1	R	150%		
	LMK107 BJ475□A		X5R	4.7	±10, ±20	10	0.8±0.1	R	150%		
6.3V	LMK107 BJ106MA	LMK107BBJ106MA	X5R	10	±20	10	0.8+0.2/-0	R	150%	D	Special code : L
	JMK107 BJ225□A		B/X5R	2.2	±10, ±20	10	0.8±0.1	R	150%		
4V	JMK107 BJ475□A		X5R	4.7	±10, ±20	10	0.8±0.1	R	150%		
	JMK107 BJ106MA	JMK107ABJ106MA	X5R	10	±20	10	0.8+0.15/-0.05	R	150%		
	AMK107 BJ106MA		X5R	10	±20	10	0.8±0.1	R	150%		
	AMK107 BJ226MA	AMK107BBJ226MA	X5R	22	±20	10	0.8+0.2/-0	R	150%		

•0.45mm thickness(K)

Rated voltage	Part number 1	Part number 2	Temp. char.	Capacitance (μF)	Capacitance tolerance (%)	tan δ (%)	Thickness (mm)	Soldering R:Reflow W:Wave	HALT	Internal code (P/N 1)	Note
									% Rated voltage		
25V	TMK107 BJ105□K		X5R	1	±10, ±20	10	0.45±0.05	R	150%		
16V	EMK107 BJ105□K		X5R	1	±10, ±20	10	0.45±0.05	R	150%		
10V	LMK107 BJ105□K		B/X5R	1	±10, ±20	10	0.45±0.05	R	150%		
	LMK107 BJ225□K		X5R	2.2	±10, ±20	10	0.45±0.05	R	150%		
6.3V	LMK107 BJ475MK	LMK107BBJ475MK	X5R	4.7	±20	10	0.45±0.05	R	150%	D	Special code : L
	JMK107 BJ105□K		B/X5R	1	±10, ±20	10	0.45±0.05	R	150%		
	JMK107 BJ225□K		X5R	2.2	±10, ±20	10	0.45±0.05	R	150%		
	JMK107 BJ475MK		X5R	4.7	±20	10	0.45±0.05	R	150%		

Capacitance tolerance code is applied to □ of part number.

*1 We may provide X7R for some items according to the individual specification.

[Temperature Characteristic B7 : X7R]
 •0.8mm thickness(A)

Rated voltage	Part number 1	Part number 2	Temp. char.	Capacitance (μF)	Capacitance tolerance (%)	tan δ (%)	Thickness (mm)	Soldering R:Reflow W:Wave	HALT	Internal code (P/N 1)	Note
									% Rated voltage		
50V	UMK107 B7224□A		X7R	0.22	±10, ±20	10	0.8±0.1	R	150%	R	
	UMK107 B7474□A		X7R	0.47	±10, ±20	10	0.8±0.1	R	150%	R	
25V	TMK107 B7474□A	UMK107AB7105□A	X7R	1	±10, ±20	10	0.8+0.15/-0.05	R	150%		
	TMK107 B7105□A		X7R	1	±10, ±20	10	0.8±0.1	R	150%	R	
16V	EMK107 B7224□A		X7R	0.22	±10, ±20	3.5	0.8±0.1	R/W	150%		
	EMK107 B7474□A		X7R	0.47	±10, ±20	3.5	0.8±0.1	R	150%		
	EMK107 B7105□A		X7R	1	±10, ±20	5	0.8±0.1	R	150%		
10V	LMK107 B7224□A		X7R	0.22	±10, ±20	3.5	0.8±0.1	R/W	200%		
	LMK107 B7474□A		X7R	0.47	±10, ±20	3.5	0.8±0.1	R	200%		
	LMK107 B7105□A		X7R	1	±10, ±20	5	0.8±0.1	R	150%		
	LMK107 B7225□A		X7R	2.2	±10, ±20	10	0.8±0.1	R	150%		
6.3V	JMK107 B7224□A		X7R	0.22	±10, ±20	3.5	0.8±0.1	R/W	200%		
	JMK107 B7474□A		X7R	0.47	±10, ±20	3.5	0.8±0.1	R	200%		
	JMK107 B7105□A		X7R	1	±10, ±20	5	0.8±0.1	R	150%		

Capacitance tolerance code is applied to □ of part number.

勝特力材料 886-3-5753170
 勝特力电子(上海) 86-21-34970699
 勝特力电子(深圳) 86-755-83298787
[Http://www.100y.com.tw](http://www.100y.com.tw)

* This catalog contains the typical specification only due to the limitation of space. When you consider the purchase of our products, please check our specification. For details of each product (characteristics graph, reliability information, precautions for use, and so on), see our Web site (<http://www.ty-top.com/>) or CD catalogs.

REPRESENTATIVE PART NUMBERS

[Temperature Characteristic F : Y5V]
·0.8mm thickness(A)

Rated voltage	Part number 1	Part number 2	Temp. char.	Capacitance (μF)	Capacitance tolerance (%)	tan δ (%)	Thickness (mm)	Soldering R:Reflow W:Wave	HALT	Internal code (P/N 1)	Note
									% Rated voltage		
50V	UMK107 F104ZA		F/Y5V	0.1	+80/-20	7	0.8±0.1	R/W	200%		
25V	TMK107 F474ZA		F/Y5V	0.47	+80/-20	7	0.8±0.1	R/W	200%		
16V	EMK107 F224ZA		F/Y5V	0.22	+80/-20	7	0.8±0.1	R/W	200%		
	EMK107 F474ZA		F/Y5V	0.47	+80/-20	7	0.8±0.1	R/W	200%		
	EMK107 F105ZA		F/Y5V	1	+80/-20	16	0.8±0.1	R	200%		
	EMK107 F225ZA		F/Y5V	2.2	+80/-20	16	0.8±0.1	R	200%		
10V	LMK107 F105ZA		F/Y5V	1	+80/-20	16	0.8±0.1	R	200%		
	LMK107 F225ZA		F/Y5V	2.2	+80/-20	16	0.8±0.1	R	200%		

212TYPE

[Temperature Characteristic BJ : B/X5R]
·1.25mm thickness(G)

Rated voltage	Part number 1	Part number 2	Temp. char.	Capacitance (μF)	Capacitance tolerance (%)	tan δ (%)	Thickness (mm)	Soldering R:Reflow W:Wave	HALT	Internal code (P/N 1)	Note
									% Rated voltage		
50V	UMK212 BJ104□G		B/X5R ⁺	0.1	±10, ±20	3.5	1.25±0.1	R/W	200%		
	UMK212 BJ224□G		B/X5R ⁺	0.22	±10, ±20	3.5	1.25±0.1	R/W	150%		
	UMK212 BJ474□G		B/X5R ⁺	0.47	±10, ±20	3.5	1.25±0.1	R/W	150%		
	UMK212 BJ105□G		B/X5R	1	±10, ±20	5	1.25±0.1	R/W	150%		
25V	TMK212 BJ225□G		B/X5R	2.2	±10, ±20	5	1.25±0.1	R	150%		
	TMK212 BJ475□G	TMK212ABJ475□G	X5R	4.7	±10, ±20	10	1.25+0.15/-0.05	R	150%		
		TMK212BBJ106MG	X5R	10	±20	10	1.25+0.2/-0	R	150%		
16V	EMK212 BJ225□G		B/X5R ⁺	2.2	±10, ±20	5	1.25±0.1	R	200%		
	EMK212 BJ475□G	EMK212ABJ475□G	B/X5R ⁺	4.7	±10, ±20	5	1.25+0.15/-0.05	R	150%		
	EMK212 BJ106□G	EMK212ABJ106□G	X5R	10	±10, ±20	10	1.25+0.15/-0.05	R	150%		
10V	LMK212 BJ225□G		B/X5R ⁺	2.2	±10, ±20	5	1.25±0.1	R	200%		
	LMK212 BJ475□G	LMK212ABJ475□G	B/X5R ⁺	4.7	±10, ±20	5	1.25+0.15/-0.05	R	200%		
	LMK212 BJ106□G	LMK212ABJ106□G	X5R	10	±10, ±20	10	1.25+0.15/-0.05	R	200%		
6.3V	LMK212 BJ226MG	LMK212BBJ226MG	X5R	22	±20	10	1.25+0.2/-0	R	150%		
	JMK212 BJ475□G	JMK212ABJ475□G	B/X5R	4.7	±10, ±20	5	1.25+0.15/-0.05	R	200%		
	JMK212 BJ106□G	JMK212ABJ106□G	X5R ⁺	10	±10, ±20	10	1.25+0.15/-0.05	R	200%		
	JMK212 BJ226MG	JMK212ABJ226MG	X5R	22	±20	10	1.25+0.15/-0.05	R	150%		
	JMK212 BJ476MG	JMK212BBJ476MG	X5R	47	±20	10	1.25+0.2/-0	R	150%		

·0.85mm thickness(D)

Rated voltage	Part number 1	Part number 2	Temp. char.	Capacitance (μF)	Capacitance tolerance (%)	tan δ (%)	Thickness (mm)	Soldering R:Reflow W:Wave	HALT	Internal code (P/N 1)	Note
									% Rated voltage		
50V	UMK212 BJ105□D	UMK212ABJ105□D	X5R	1	±10, ±20	10	0.85±0.1	R	150%	D	
25V	TMK212 BJ474□D		B/X5R	0.47	±10, ±20	3.5	0.85±0.1	R	200%		
	TMK212 BJ105□D		B/X5R	1	±10, ±20	5	0.85±0.1	R	200%		
	TMK212 BJ225□D	TMK212ABJ225□D	B/X5R	2.2	±10, ±20	5	0.85±0.1	R	150%		
	TMK212 BJ475□D	TMK212BBJ475□D	X5R	4.7	±10, ±20	10	0.85±0.1	R	150%	D	
16V	EMK212 BJ105□D		B/X5R ⁺	1	±10, ±20	5	0.85±0.1	R	200%		
	EMK212 BJ225□D	EMK212ABJ225□D	B/X5R ⁺	2.2	±10, ±20	5	0.85±0.1	R	200%		
	EMK212 BJ475□D		B/X5R	4.7	±10, ±20	10	0.85±0.1	R	150%		
	EMK212 BJ106□D	EMK212ABJ106□D	X5R	10	±10, ±20	10	0.85±0.1	R	150%	D	
10V	LMK212 BJ105□D		B/X5R ⁺	1	±10, ±20	3.5	0.85±0.1	R	200%		
	LMK212 BJ225□D		B/X5R ⁺	2.2	±10, ±20	5	0.85±0.1	R	200%		
	LMK212 BJ475□D		B/X5R	4.7	±10, ±20	10	0.85±0.1	R	200%		
	LMK212 BJ106□D	LMK212ABJ106□D	X5R	10	±10, ±20	10	0.85±0.1	R	150%		
6.3V	JMK212 BJ475□D		X5R	4.7	±10, ±20	10	0.85±0.1	R	200%		
	JMK212 BJ106□D	JMK212ABJ106□D	X5R	10	±10, ±20	10	0.85±0.1	R	200%		
	JMK212 BJ226MD	JMK212ABJ226MD	X5R	22	±20	10	0.85±0.1	R	150%		

·0.45mm thickness(K)

Rated voltage	Part number 1	Part number 2	Temp. char.	Capacitance (μF)	Capacitance tolerance (%)	tan δ (%)	Thickness (mm)	Soldering R:Reflow W:Wave	HALT	Internal code (P/N 1)	Note
									% Rated voltage		
10V	LMK212 BJ475□K	LMK212ABJ475□K	X5R	4.7	±10, ±20	10	0.45±0.05	R	150%		
6.3V	JMK212 BJ475□K	JMK212ABJ475□K	X5R	4.7	±10, ±20	10	0.45±0.05	R	150%		
	JMK212 BJ106MK	JMK212ABJ106MK	X5R	10	±20	10	0.45±0.05	R	150%		

Capacitance tolerance code is applied to □ of part number.

*1 We may provide X7R for some items according to the individual specification.

勝特力材料 886-3-5753170
 勝特力电子(上海) 86-21-34970699
 勝特力电子(深圳) 86-755-83298787
[Http://www.100y.com.tw](http://www.100y.com.tw)

REPRESENTATIVE PART NUMBERS

【Temperature Characteristic B7 : X7R】
 ・1.25mm thickness(G)

Rated voltage	Part number 1	Part number 2	Temp. char.	Capacitance (μF)	Capacitance tolerance (%)	tan δ (%)	Thickness (mm)	Soldering R:Reflow W:Wave	HALT % Rated voltage	Internal code (P/N 1)	Note
50V	UMK212 B7104□G		X7R	0.1	±10, ±20	3.5	1.25±0.1	R/W	200%		
	UMK212 B7224□G		X7R	0.22	±10, ±20	3.5	1.25±0.1	R/W	150%		
	UMK212 B7474□G		X7R	0.47	±10, ±20	3.5	1.25±0.1	R/W	150%		
	UMK212 B7105□G		X7R	1	±10, ±20	10	1.25±0.1	R/W	150%		
		UMK212BB7225□G	X7R	2.2	±10, ±20	10	1.25+0.2/-0	R	150%		
35V	GMK212 B7105□G		X7R	1	±10, ±20	3.5	1.25±0.1	R/W	150%		
25V	TMK212 B7105□G		X7R	1	±10, ±20	3.5	1.25±0.1	R/W	150%		
	TMK212 B7225□G		X7R	2.2	±10, ±20	10	1.25±0.1	R	150%	R	
	TMK212 B7475□G	TMK212AB7475□G	X7R	4.7	±10, ±20	10	1.25+0.15/-0.05	R	150%	D	
16V	EMK212 B7105□G		X7R	1	±10, ±20	3.5	1.25±0.1	R/W	200%		
	EMK212 B7225□G		X7R	2.2	±10, ±20	10	1.25±0.1	R	150%		
	EMK212 B7475□G		X7R	4.7	±10, ±20	10	1.25±0.1	R	150%		
		EMK212BB7106MG		X7R	10	±20	10	1.25+0.2/-0	R	150%	
10V	LMK212 B7105□G		X7R	1	±10, ±20	3.5	1.25±0.1	R/W	200%		
	LMK212 B7225□G		X7R	2.2	±10, ±20	5	1.25±0.1	R	200%		
	LMK212 B7475□G		X7R	4.7	±10, ±20	10	1.25±0.1	R	150%		
	LMK212 B7106MG	LMK212AB7106MG	X7R	10	±20	10	1.25+0.15/-0.05	R	150%	D	
6.3V	JMK212 B7106□G	JMK212AB7106□G	X7R	10	±10, ±20	10	1.25+0.15/-0.05	R	150%		

・0.85mm thickness(D)

Rated voltage	Part number 1	Part number 2	Temp. char.	Capacitance (μF)	Capacitance tolerance (%)	tan δ (%)	Thickness (mm)	Soldering R:Reflow W:Wave	HALT % Rated voltage	Internal code (P/N 1)	Note
50V		UMK212AB7104□D	X7R	0.1	±10, ±20	10	0.85±0.1	R	150%		
		UMK212AB7224□D	X7R	0.22	±10, ±20	10	0.85±0.1	R	150%		
		UMK212AB7474□D	X7R	0.47	±10, ±20	10	0.85±0.1	R	150%		
		UMK212AB7105□D	X7R	1	±10, ±20	10	0.85±0.1	R	150%		
25V		TMK212AB7225□D	X7R	2.2	±10, ±20	10	0.85±0.1	R	150%	R	
		EMK212 B7474□D	X7R	0.47	±10, ±20	3.5	0.85±0.1	R/W	200%		
16V	EMK212 B7105□D		X7R	1	±10, ±20	5	0.85±0.1	R	200%		
	EMK212 B7225□D	EMK212AB7225□D	X7R	2.2	±10, ±20	5	0.85±0.1	R	150%		
10V	LMK212 B7105□D		X7R	1	±10, ±20	3.5	0.85±0.1	R	200%		
	LMK212 B7225□D	LMK212AB7225□D	X7R	2.2	±10, ±20	5	0.85±0.1	R	200%		
	LMK212 B7475□D	LMK212AB7475□D	X7R	4.7	±10, ±20	10	0.85±0.1	R	150%	R	

Capacitance tolerance code is applied to □ of part number.

【Temperature Characteristic F : Y5V】
 ・1.25mm thickness(G)

Rated voltage	Part number 1	Part number 2	Temp. char.	Capacitance (μF)	Capacitance tolerance (%)	tan δ (%)	Thickness (mm)	Soldering R:Reflow W:Wave	HALT % Rated voltage	Internal code (P/N 1)	Note
50V	UMK212 F474ZG		F/Y5V	0.47	+80/-20	7	1.25±0.1	R/W	200%		
	UMK212 F105ZG		F/Y5V	1	+80/-20	7	1.25±0.1	R/W	200%		
16V	EMK212 F225ZG		F/Y5V	2.2	+80/-20	7	1.25±0.1	R/W	200%		
10V	LMK212 F475ZG		F/Y5V	4.7	+80/-20	9	1.25±0.1	R	200%		
	LMK212 F106ZG		F/Y5V	10	+80/-20	16	1.25±0.1	R	200%		
6.3V	JMK212 F106ZG		F/Y5V	10	+80/-20	16	1.25±0.1	R	200%		

・0.85mm thickness(D)

Rated voltage	Part number 1	Part number 2	Temp. char.	Capacitance (μF)	Capacitance tolerance (%)	tan δ (%)	Thickness (mm)	Soldering R:Reflow W:Wave	HALT % Rated voltage	Internal code (P/N 1)	Note
50V	UMK212 F224ZD		F/Y5V	0.22	+80/-20	7	0.85±0.1	R/W	200%		
10V	LMK212 F225ZD		F/Y5V	2.2	+80/-20	9	0.85±0.1	R	200%		
6.3V	JMK212 F475ZD		F/Y5V	4.7	+80/-20	16	0.85±0.1	R	200%		

●316Type

【Temperature Characteristic BJ : B/X5R】
 ・1.6mm thickness(L)

Rated voltage	Part number 1	Part number 2	Temp. char.	Capacitance (μF)	Capacitance tolerance (%)	tan δ (%)	Thickness (mm)	Soldering R:Reflow W:Wave	HALT % Rated voltage	Internal code (P/N 1)	Note
50V	UMK316 BJ105□L		B/X5R ^{*1}	1	±10, ±20	3.5	1.6±0.2	R	200%		
	UMK316 BJ475□L		X5R	4.7	±10, ±20	10	1.6±0.2	R	150%		
25V	TMK316 BJ225□L		B/X5R ^{*1}	2.2	±10, ±20	3.5	1.6±0.2	R	200%		
	TMK316 BJ475□L		B/X5R	4.7	±10, ±20	5	1.6±0.2	R	150%		
16V	TMK316 BJ106□L		X5R ^{*1}	10	±10, ±20	5	1.6±0.2	R	150%		
	EMK316 BJ225□L		B/X5R ^{*1}	2.2	±10, ±20	3.5	1.6±0.2	R/W	200%		
10V	EMK316 BJ475□L		B/X5R	4.7	±10, ±20	5	1.6±0.2	R	200%		
	EMK316 BJ106□L		B/X5R ^{*1}	10	±10, ±20	5	1.6±0.2	R	150%		
	EMK316 BJ226ML	EMK316ABJ226ML	B/X5R	22	±20	10	1.6±0.2	R	150%		
	LMK316 BJ106□L		B/X5R ^{*1}	10	±10, ±20	5	1.6±0.2	R	200%		
6.3V	LMK316 BJ226ML	LMK316ABJ226ML	B/X5R	22	±20	10	1.6±0.2	R	150%		
	LMK316 BJ476ML	LMK316ABJ476ML	X5R	47	±20	10	1.6±0.2	R	150%		
	JMK316 BJ106□L		B/X5R ^{*1}	10	±10, ±20	5	1.6±0.2	R	200%		
	JMK316 BJ226□L	JMK316ABJ226□L	B/X5R	22	±10, ±20	10	1.6±0.2	R	200%		
4V	JMK316 BJ476ML	JMK316ABJ476ML	X5R	47	±20	10	1.6±0.2	R	200%		
	JMK316 BJ107ML	JMK316ABJ107ML	X5R	100	±20	10	1.6±0.2	R	150%		
	AMK316 BJ107ML	AMK316ABJ107ML	X5R	100	±20	10	1.6±0.2	R	150%		

Capacitance tolerance code is applied to □ of part number.

*1 We may provide X7R for some items according to the individual specification.

* This catalog contains the typical specification only due to the limitation of space. When you consider the purchase of our products, please check our specification. For details of each product (characteristics graph, reliability information, precautions for use, and so on), see our Web site (http://www.ty-top.com/) or CD catalogs.

REPRESENTATIVE PART NUMBERS

·0.85mm thickness(D)

Rated voltage	Part number 1	Part number 2	Temp. char.	Capacitance [μF]	Capacitance tolerance [%]	tan δ [%]	Thickness (mm)	Soldering R:Reflow W:Wave	HALT	Internal code (P/N 1)	Note
									% Rated voltage		
50V	UMK316 BJ105□D		B/X5R	1	±10, ±20	3.5	0.85±0.1	R	150%		
	UMK316 BJ225□D		B/X5R	2.2	±10, ±20	3.5	0.85±0.1	R	150%		
	UMK316 BJ475□D	UMK316ABJ475□D	X5R	4.7	±10, ±20	10	0.85±0.1	R	150%	D	
25V	TMK316 BJ105□D		B/X5R	1	±10, ±20	3.5	0.85±0.1	R	200%		
	TMK316 BJ225□D		B/X5R	2.2	±10, ±20	3.5	0.85±0.1	R	150%		
	TMK316 BJ475□D		X5R	4.7	±10, ±20	5	0.85±0.1	R	150%		
	TMK316 BJ106□D	TMK316ABJ106□D	X5R	10	±10, ±20	10	0.85±0.1	R	150%	D	
16V	EMK316 BJ225□D		B/X5R	2.2	±10, ±20	3.5	0.85±0.1	R	200%		
	EMK316 BJ475□D		B/X5R	4.7	±10, ±20	5	0.85±0.1	R	200%		
	EMK316 BJ106□D		X5R	10	±10, ±20	10	0.85±0.1	R	150%		
	EMK316 BJ226MD	EMK316ABJ226MD	X5R	22	±20	10	0.85±0.1	R	150%	D	
10V	LMK316 BJ475□D		B/X5R	4.7	±10, ±20	5	0.85±0.1	R	200%		
	LMK316 BJ106□D		B/X5R	10	±10, ±20	10	0.85±0.1	R	200%		
	LMK316 BJ226MD	LMK316ABJ226MD	X5R	22	±20	10	0.85±0.1	R	150%		
6.3V	JMK316 BJ106□D		B/X5R	10	±10, ±20	10	0.85±0.1	R	200%		
	JMK316 BJ226MD	JMK316ABJ226MD	X5R	22	±20	10	0.85±0.1	R	150%		
	JMK316 BJ476MD	JMK316ABJ476MD	X5R	47	±20	10	0.85±0.1	R	150%		

Capacitance tolerance code is applied to □ of part number.

[Temperature Characteristic B7 : X7R]

·1.6mm thickness(L)

Rated voltage	Part number 1	Part number 2	Temp. char.	Capacitance [μF]	Capacitance tolerance [%]	tan δ [%]	Thickness (mm)	Soldering R:Reflow W:Wave	HALT	Internal code (P/N 1)	Note
									% Rated voltage		
50V	UMK316 B7224□L		X7R	0.22	±10, ±20	2.5	1.6±0.2	R/W	200%		
	UMK316 B7474□L		X7R	0.47	±10, ±20	3.5	1.6±0.2	R/W	200%		
	UMK316 B7105□L		X7R	1	±10, ±20	3.5	1.6±0.2	R	200%		
	UMK316 B7225□L		X7R	2.2	±10, ±20	10	1.6±0.2	R	150%		
	UMK316 B7475□L	UMK316AB7475□L	X7R	4.7	±10, ±20	10	1.6±0.2	R	150%	D	
25V	TMK316 B7105□L		X7R	1	±10, ±20	3.5	1.6±0.2	R/W	200%		
	TMK316 B7225□L		X7R	2.2	±10, ±20	3.5	1.6±0.2	R	200%		
	TMK316 B7475□L	TMK316AB7475□L	X7R	4.7	±10, ±20	10	1.6±0.2	R	200%	D	
	TMK316 B7106□L	TMK316AB7106□L	X7R	10	±10, ±20	10	1.6±0.2	R	150%	D	
16V	EMK316 B7225□L		X7R	2.2	±10, ±20	3.5	1.6±0.2	R/W	200%		
	EMK316 B7106□L	EMK316AB7106□L	X7R	10	±10, ±20	10	1.6±0.2	R	200%	D	
10V	LMK316 B7225□L		X7R	2.2	±10, ±20	3.5	1.6±0.2	R/W	200%		
	LMK316 B7475□L		X7R	4.7	±10, ±20	5	1.6±0.2	R	200%		
	LMK316 B7106□L	LMK316AB7106□L	X7R	10	±10, ±20	10	1.6±0.2	R	200%	D	
	LMK316 B7226ML	LMK316AB7226ML	X7R	22	±20	10	1.6±0.2	R	150%	R	
6.3V	JMK316 B7106□L		X7R	10	±10, ±20	5	1.6±0.2	R	200%		

Capacitance tolerance code is applied to □ of part number.

·0.85mm thickness(D)

Rated voltage	Part number 1	Part number 2	Temp. char.	Capacitance [μF]	Capacitance tolerance [%]	tan δ [%]	Thickness (mm)	Soldering R:Reflow W:Wave	HALT	Internal code (P/N 1)	Note
									% Rated voltage		
50V	UMK316 B7225□D		X7R	2.2	±10, ±20	10	0.85±0.1	R	150%		
25V		TMK316AB7475□D	X7R	4.7	±10, ±20	10	0.85±0.1	R	150%		
10V		LMK316AB7106MD	X7R	10	±20	10	0.85±0.1	R	150%		

Capacitance tolerance code is applied to □ of part number.

[Temperature Characteristic F : F/Y5V]

·1.6mm thickness(L)

Rated voltage	Part number 1	Part number 2	Temp. char.	Capacitance [μF]	Capacitance tolerance [%]	tan δ [%]	Thickness (mm)	Soldering R:Reflow W:Wave	HALT	Internal code (P/N 1)	Note
									% Rated voltage		
35V	GMK316 F106ZL		F/Y5V	10	+80/-20	9	1.6±0.2	R	200%		
25V	TMK316 F106ZL		F/Y5V	10	+80/-20	9	1.6±0.2	R	200%		
16V	EMK316 F106ZL		F/Y5V	10	+80/-20	9	1.6±0.2	R	200%		
10V	LMK316 F226ZL		F/Y5V	22	+80/-20	16	1.6±0.2	R	200%		

·1.25mm thickness(G)

Rated voltage	Part number 1	Part number 2	Temp. char.	Capacitance [μF]	Capacitance tolerance [%]	tan δ [%]	Thickness (mm)	Soldering R:Reflow W:Wave	HALT	Internal code (P/N 1)	Note
									% Rated voltage		
50V	UMK316 F225ZG		F/Y5V	2.2	+80/-20	7	1.25±0.1	R/W	200%		
35V	GMK316 F475ZG		F/Y5V	4.7	+80/-20	7	1.25±0.1	R	200%		

·0.85mm thickness(D)

Rated voltage	Part number 1	Part number 2	Temp. char.	Capacitance [μF]	Capacitance tolerance [%]	tan δ [%]	Thickness (mm)	Soldering R:Reflow W:Wave	HALT	Internal code (P/N 1)	Note
									% Rated voltage		
10V	LMK316 F475ZD		F/Y5V	4.7	+80/-20	9	0.85±0.1	R	200%		
6.3V	JMK316 F106ZD		F/Y5V	10	+80/-20	16	0.85±0.1	R	200%		

勝特力材料 886-3-5753170
 勝特力电子(上海) 86-21-34970699
 勝特力电子(深圳) 86-755-83298787
[Http://www.100y.com.tw](http://www.100y.com.tw)

* This catalog contains the typical specification only due to the limitation of space. When you consider the purchase of our products, please check our specification. For details of each product (characteristics graph, reliability information, precautions for use, and so on), see our Web site (<http://www.ty-top.com/>) or CD catalogs.

REPRESENTATIVE PART NUMBERS

勝特力材料 886-3-5753170
 勝特力电子(上海) 86-21-34970699
 勝特力电子(深圳) 86-755-83298787
[Http://www.100y.com.tw](http://www.100y.com.tw)

●325Type

[Temperature Characteristic BJ : B/X5R]
 *2.5mm thickness (M)

Rated voltage	Part number 1	Part number 2	Temp. char.	Capacitance (μF)	Capacitance tolerance (%)	tan δ (%)	Thickness (mm)	Soldering R:Reflow W:Wave	HALT	Internal code (P/N 1)	Note
									% Rated voltage		
50V	UMK325 BJ475MM		X5R	4.7	±20	5	2.5±0.2	R	150%		
	UMK325 BJ106MM		X5R	10	±20	5	2.5±0.2	R	150%		
25V	TMK325 BJ106MM		B/X5R*1	10	±20	3.5	2.5±0.2	R	150%		
16V	EMK325 BJ226MM		B/X5R	22	±20	5	2.5±0.2	R	150%		
	EMK325 BJ476MM		X5R	47	±20	10	2.5±0.2	R	150%		
10V	LMK325 BJ226MM		B/X5R	22	±20	5	2.5±0.2	R	200%		
	LMK325 BJ476MM		X5R	47	±20	10	2.5±0.2	R	150%		
	LMK325 BJ107MM	LMK325ABJ107MM	X5R	100	±20	10	2.5±0.3	R	150%		
6.3V	JMK325 BJ476MM		X5R	47	±20	10	2.5±0.2	R	150%		
	JMK325 BJ107MM	JMK325ABJ107MM	X5R	100	±20	10	2.5±0.3	R	150%		

*1.9mm thickness (Y, N)

Rated voltage	Part number 1	Part number 2	Temp. char.	Capacitance (μF)	Capacitance tolerance (%)	tan δ (%)	Thickness (mm)	Soldering R:Reflow W:Wave	HALT	Internal code (P/N 1)	Note
									% Rated voltage		
50V	UMK325 BJ475MN		X5R	4.7	±20	10	1.9±0.2	R	150%		
35V	GMK325 BJ225MN		B/X5R	2.2	±20	3.5	1.9±0.2	R	200%		
	GMK325 BJ475MN		X5R	4.7	±20	10	1.9±0.2	R	150%		
25V	GMK325 BJ106MN		B/X5R	10	±20	5	1.9±0.2	R	150%		
	TMK325 BJ335MN		B/X5R*1	3.3	±20	3.5	1.9±0.2	R	200%		
16V	TMK325 BJ475MN		B/X5R*1	4.7	±20	3.5	1.9±0.2	R	200%		
	TMK325 BJ106MN		B/X5R	10	±20	5	1.9±0.2	R	200%		
	EMK325 BJ475MN		B/X5R*1	4.7	±20	3.5	1.9±0.2	R	200%		
10V	EMK325 BJ106MN		B/X5R	10	±20	3.5	1.9±0.2	R	200%		
	EMK325 BJ476MY		X5R	47	±20	10	1.9+0.1/-0.2	R	150%		
	LMK325 BJ226MY		B/X5R	22	±20	5	1.9+0.1/-0.2	R	150%		
6.3V	LMK325 BJ106MN		B/X5R*1	10	±20	3.5	1.9±0.2	R	200%		
	JMK325 BJ226MY		B/X5R	22	±20	5	1.9+0.1/-0.2	R	200%		
	JMK325 BJ107MY		X5R	100	±20	10	1.9+0.1/-0.2	R	150%		
	JMK325 BJ476MN		X5R	47	±20	10	1.9±0.2	R	150%		

*0.85mm thickness (D)

Rated voltage	Part number 1	Part number 2	Temp. char.	Capacitance (μF)	Capacitance tolerance (%)	tan δ (%)	Thickness (mm)	Soldering R:Reflow W:Wave	HALT	Internal code (P/N 1)	Note
									% Rated voltage		
25V	TMK325 BJ106MD		B/X5R	10	±20	5	0.85±0.1	R	150%		
16V	EMK325 BJ106MD		B/X5R	10	±20	5	0.85±0.1	R	150%		
	EMK325 BJ226MD		B/X5R	22	±20	10	0.85±0.1	R	150%		
10V	LMK325 BJ335MD		B/X5R	3.3	±20	3.5	0.85±0.1	R	200%		
	LMK325 BJ475MD		B/X5R	4.7	±20	5	0.85±0.1	R	200%		
	LMK325 BJ106MD		B/X5R	10	±20	5	0.85±0.1	R	150%		

*1 We may provide X7R for some items according to the individual specification.

[Temperature Characteristic B7 : X7R]
 *2.5mm thickness (M)

Rated voltage	Part number 1	Part number 2	Temp. char.	Capacitance (μF)	Capacitance tolerance (%)	tan δ (%)	Thickness (mm)	Soldering R:Reflow W:Wave	HALT	Internal code (P/N 1)	Note
									% Rated voltage		
50V	UMK325 B7475MM		X7R	4.7	±20	5	2.5±0.2	R	150%		
		UMK325AB7106MM	X7R	10	±20	10	2.5±0.3	R	150%		
25V	TMK325 B7226MM		X7R	22	±20	10	2.5±0.2	R	150%	R	
		TMK325AB7106MM	X7R	10	±20%	10	2.5±0.3	R	150%		
16V	EMK325 B7226MM		X7R	22	±20	10	2.5±0.2	R	150%	R	
10V	LMK325 B7476MM		X7R	47	±20	10	2.5±0.2	R	150%	R	
6.3V	JMK325 B7476MM		X7R	47	±20	10	2.5±0.2	R	200%	R	

*1.9mm thickness (N)

Rated voltage	Part number 1	Part number 2	Temp. char.	Capacitance (μF)	Capacitance tolerance (%)	tan δ (%)	Thickness (mm)	Soldering R:Reflow W:Wave	HALT	Internal code (P/N 1)	Note
									% Rated voltage		
50V	UMK325 B7475MN		X7R	4.7	±20	10	1.9±0.2	R	150%	R	
25V	TMK325 B7335MN		X7R	3.3	±20	3.5	1.9±0.2	R	200%		
	TMK325 B7475MN		X7R	4.7	±20	3.5	1.9±0.2	R	150%		
	TMK325 B7106MN		X7R	10	±20	10	1.9±0.2	R	150%	R	
16V	EMK325 B7475MN		X7R	4.7	±20	3.5	1.9±0.2	R	200%		
	EMK325 B7106MN		X7R	10	±20	3.5	1.9±0.2	R	150%		
10V	LMK325 B7106MN		X7R	10	±20	3.5	1.9±0.2	R	200%		

[Temperature Characteristic F : F/Y5V]
 *1.9mm thickness (N)

Rated voltage	Part number 1	Part number 2	Temp. char.	Capacitance (μF)	Capacitance tolerance (%)	tan δ (%)	Thickness (mm)	Soldering R:Reflow W:Wave	HALT	Internal code (P/N 1)	Note
									% Rated voltage		
16V	EMK325 F226ZN		F/Y5V	22	+80/-20	16	1.9±0.2	R	200%		
10V	LMK325 F226ZN		F/Y5V	22	+80/-20	16	1.9±0.2	R	200%		
6.3V	JMK325 F476ZN		F/Y5V	47	+80/-20	16	1.9±0.2	R	200%		

* This catalog contains the typical specification only due to the limitation of space. When you consider the purchase of our products, please check our specification. For details of each product (characteristics graph, reliability information, precautions for use, and so on), see our Web site (<http://www.ty-top.com/>) or CD catalogs.

ELECTRICAL CHARACTERISTICS

● Example of Impedance ESR vs. Frequency characteristics

■ Taiyo Yuden multilayer ceramic capacitor



勝特力材料 886-3-5753170
勝特力电子(上海) 86-21-34970699
勝特力电子(深圳) 86-755-83298787
[Http://www.100y.com.tw](http://www.100y.com.tw)

* This catalog contains the typical specification only due to the limitation of space. When you consider the purchase of our products, please check our specification. For details of each product (characteristics graph, reliability information, precautions for use, and so on), see our Web site (<http://www.ty-top.com/>) or CD catalogs.

勝特力材料 886-3-5753170
勝特力电子(上海) 86-21-34970699
勝特力电子(深圳) 86-755-83298787
[Http://www.100y.com.tw](http://www.100y.com.tw)

* This catalog contains the typical specification only due to the limitation of space. When you consider the purchase of our products, please check our specification.
For details of each product (characteristics graph, reliability information, precautions for use, and so on), see our Web site (<http://www.ty-top.com/>) or CD catalogs.

PACKAGING

① Minimum Quantity

● Taped package

Type	Thickness		Standard quantity [pcs]			
	mm	code	Paper tape	Embossed tape		
□MK042	0.2	C, D	—	40000		
□MK063	0.3	P, T	15000	—		
□2K096	0.3	P	10000			
□WK105	0.45	K				
□MK105	0.2	C	20000			
□MK105	0.3	P	15000			
□VK105	0.5	V, W	10000			
□VK105	0.5	W				
□MK107	0.45	K	4000			
□WK107	0.5	V	—		4000	
	0.8	A	4000		—	
□2K110	0.5	V				
□2K110	0.6	B				
□2K110	0.8	A				
□MK212	0.45	K				
□WK212	0.85	D				
□4K212	1.25	G		—		3000
□4K212	0.85	D		4000		—
□2K212	0.85	D				
□MK316	1.15	F		—		3000
□MK316	1.25	G				
□MK316	1.6	L				
□MK325	0.85	D	—	2000		
□MK325	1.15	F				
□MK325	1.9	N				
□MK325	2.0max	Y				
□MK432	2.5	M	—	500(T), 1000(P)		
□MK432	2.5	M	—	500		

② Taping material

※No bottom tape for pressed carrier tape

● Paper tape

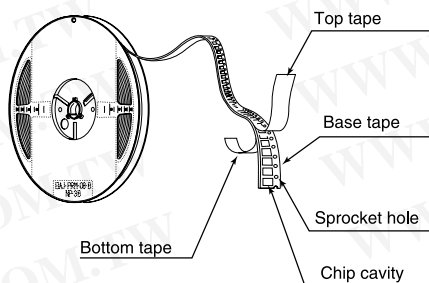

● Embossed tape

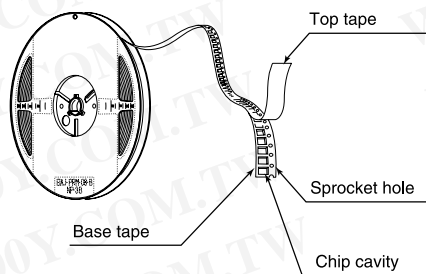

● Chip filled

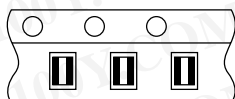
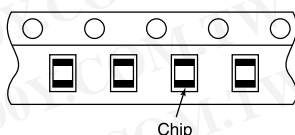

③ Representative taping dimensions

● Paper Tape (8mm wide)

● Pressed carrier tape (2mm pitch)

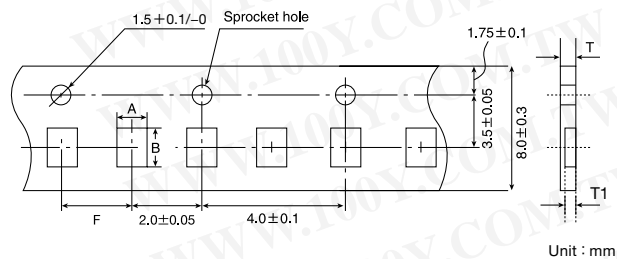

Type	Chip Cavity		Insertion Pitch	Tape Thickness	
	A	B		T	T1
□MK063	0.37	0.67	2.0±0.05	0.45max.	0.42max.
□2K096	0.65	1.02			
□WK105	0.65	1.15		0.4max.	0.3max.
MK105(+C)				0.45max.	0.42max.
MK105(+P)					

* Thickness, C : 0.2mm, P : 0.3mm

● Punched carrier tape (2mm pitch)

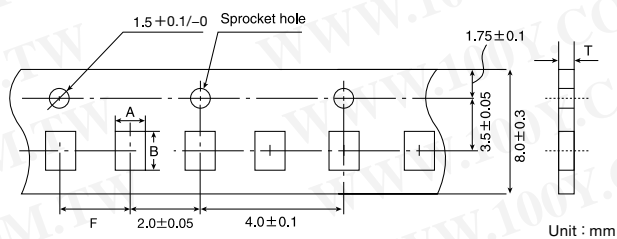

Type	Chip Cavity		Insertion Pitch	Tape Thickness	
	A	B		T	T1
□2K096	0.72	1.02	2.0±0.05	0.6max.	0.8max.
□MK105	0.65	1.15			
□VK105					

● Punched carrier tape (4mm pitch)

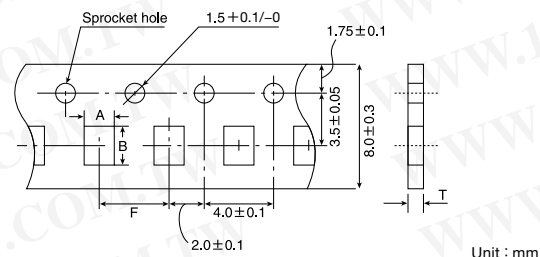

Type	Chip Cavity		Insertion Pitch	Tape Thickness	
	A	B		T	T1
□MK107	1.0	1.8	4.0±0.1	1.1max.	1.0max.
□WK107					
□2K110	1.15	1.55		1.1max.	
□MK212					
□WK212	1.65	2.4			
□4K212					
□2K212	2.0	3.6			
□MK316					

勝特力材料 886-3-5753170
 勝特力电子(上海) 86-21-34970699
 勝特力电子(深圳) 86-755-83298787
[Http://www.100y.com.tw](http://www.100y.com.tw)

Note : Taping size might be different depending on the size of the product.

* This catalog contains the typical specification only due to the limitation of space. When you consider the purchase of our products, please check our specification. For details of each product (characteristics graph, reliability information, precautions for use, and so on), see our Web site (<http://www.ty-top.com/>) or CD catalogs.

PACKAGING

● Embossed tape (4mm wide)

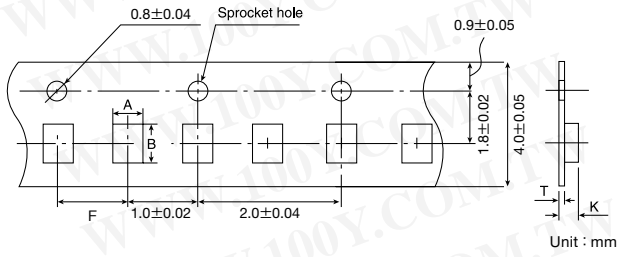

Type	Chip Cavity		Insertion Pitch F	Tape Thickness	
	A	B		K	T
□MK042	0.23	0.43	1.0±0.02	0.5max.	0.25max.

● Embossed tape (8mm wide)

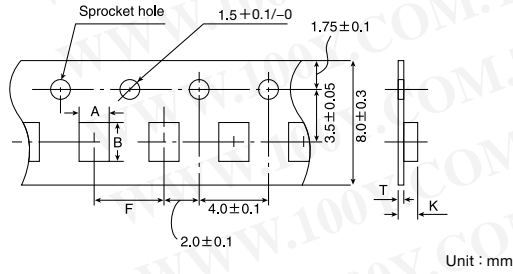

Type	Chip Cavity		Insertion Pitch F	Tape Thickness	
	A	B		K	T
□WK107	1.0	1.8	4.0±0.1	1.3max	0.25±0.1
□MK212	1.65	2.4		3.4max.	0.6max.
□MK316	2.0	3.6			
□MK325	2.8	3.6			

● Embossed tape (12mm wide)

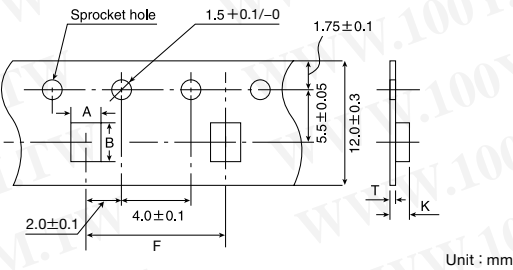

Type	Chip Cavity		Insertion Pitch F	Tape Thickness	
	A	B		K	T
□MK432	3.7	4.9	8.0±0.1	4.0max.	0.6max.

勝特力材料 886-3-5753170
勝特力电子(上海) 86-21-34970699
勝特力电子(深圳) 86-755-83298787
[Http://www.100y.com.tw](http://www.100y.com.tw)

④ Trailer and Leader

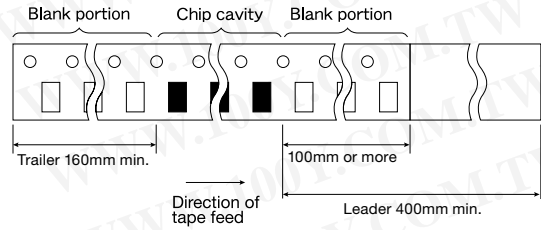

⑤ Reel size

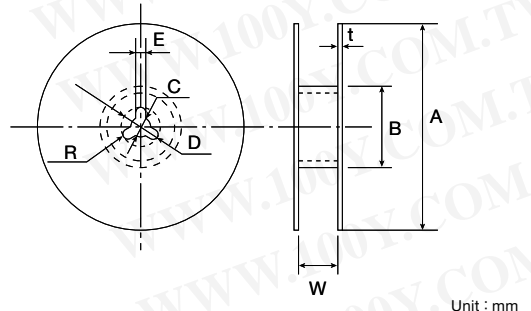

A	B	C
φ178±2.0	φ50min.	φ13.0±0.2
D	E	R
φ21.0±0.8	2.0±0.5	1.0
t		W
4mm wide tape		1.5max.
8mm wide tape		2.5max.
12mm wide tape		2.5max.
		5±1.0
		10±1.5
		14±1.5

⑥ Top Tape Strength

The top tape requires a peel-off force of 0.1 to 0.7N in the direction of the arrow as illustrated below.

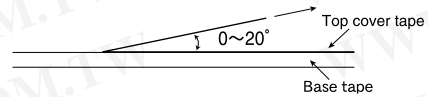

⑦ Bulk Cassette

The exchange of individual specification is necessary. Please contact Taiyo Yuden sales channels.

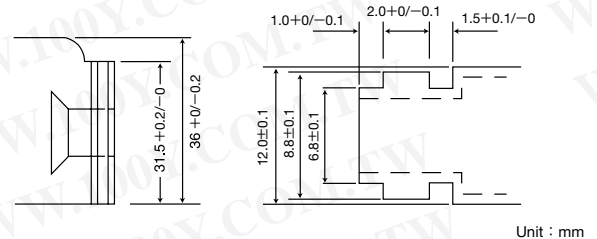
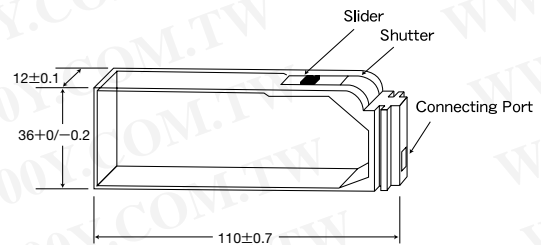

* This catalog contains the typical specification only due to the limitation of space. When you consider the purchase of our products, please check our specification. For details of each product (characteristics graph, reliability information, precautions for use, and so on), see our Web site (<http://www.ty-top.com/>) or CD catalogs.

Super Low Distortion Multilayer Ceramic Capacitors and Medium-High Voltage Multilayer Ceramic Capacitors are noted separately.

Multilayer Ceramic Capacitors

1. Operating Temperature Range

Specified Value	Temperature Compensating (Class 1)	Standard	-55 to +125°C	
	High Permittivity (Class 2)	High Frequency Type	Specification	Temperature Range
BJ		B	-25 to +85°C	
		X5R	-55 to +85°C	
B7		X7R	-55 to +125°C	
C6		X6S	-55 to +105°C	
C7		X7S	-55 to +125°C	
F	F	-25 to +85°C		
	Y5V	-30 to +85°C		

勝特力材料 886-3-5753170
勝特力电子(上海) 86-21-34970699
勝特力电子(深圳) 86-755-83298787
[Http://www.100y.com.tw](http://www.100y.com.tw)

2. Storage Conditions

Specified Value	Temperature Compensating (Class 1)	Standard	-55 to +125°C	
	High Permittivity (Class 2)	High Frequency Type	Specification	Temperature Range
BJ		B	-25 to +85°C	
		X5R	-55 to +85°C	
B7		X7R	-55 to +125°C	
C6		X6S	-55 to +105°C	
C7		X7S	-55 to +125°C	
F	F	-25 to +85°C		
	Y5V	-30 to +85°C		

3. Rated Voltage

Specified Value	Temperature Compensating (Class 1)	Standard	50VDC, 25VDC, 16VDC
	High Permittivity (Class 2)	High Frequency Type	50VDC, 16VDC
			50VDC, 35VDC, 25VDC, 16VDC, 10VDC, 6.3VDC, 4VDC

4. Withstanding Voltage (Between terminals)

Specified Value	Temperature Compensating (Class 1)	Standard	No breakdown or damage
	High Permittivity (Class 2)	High Frequency Type	

[Test Methods and Remarks]

	Class 1	Class 2
Applied voltage	Rated voltage×3	Rated voltage×2.5
Duration	1 to 5 sec.	
Charge/discharge current	50mA max.	

5. Insulation Resistance

Specified Value	Temperature Compensating (Class 1)	Standard	10000 MΩ min.
	High Permittivity (Class 2) Note 1	High Frequency Type	C≤0.047μF : 10000 MΩ min. C>0.047μF : 500MΩ·μF

[Test Methods and Remarks]

Applied voltage: Rated voltage
Duration: 60±5 sec.
Charge/discharge current: 50mA max.

6. Capacitance (Tolerance)

Specified Value	Temperature Compensating (Class 1)	Standard	<table border="1"> <tr> <td>C△</td> <td>0.5pF≤C≤5pF : ±0.25pF</td> <td>RH</td> <td>0.5pF≤C≤2pF : ±0.1pF</td> </tr> <tr> <td>U△</td> <td>0.5pF<C≤10pF : ±0.5pF</td> <td>S△</td> <td>0.5pF<C≤10pF : ±0.5pF</td> </tr> <tr> <td></td> <td>C>10pF : ±5%</td> <td>T△</td> <td>C>2pF : ±5%</td> </tr> </table>	C△	0.5pF≤C≤5pF : ±0.25pF	RH	0.5pF≤C≤2pF : ±0.1pF	U△	0.5pF<C≤10pF : ±0.5pF	S△	0.5pF<C≤10pF : ±0.5pF		C>10pF : ±5%	T△	C>2pF : ±5%
		C△	0.5pF≤C≤5pF : ±0.25pF	RH	0.5pF≤C≤2pF : ±0.1pF										
	U△	0.5pF<C≤10pF : ±0.5pF	S△	0.5pF<C≤10pF : ±0.5pF											
	C>10pF : ±5%	T△	C>2pF : ±5%												
High Frequency Type	<table border="1"> <tr> <td>CH</td> <td>0.5pF≤C≤2pF : ±0.1pF</td> </tr> <tr> <td>RH</td> <td>C>2pF : ±5%</td> </tr> </table>	CH	0.5pF≤C≤2pF : ±0.1pF	RH	C>2pF : ±5%										
CH	0.5pF≤C≤2pF : ±0.1pF														
RH	C>2pF : ±5%														
High Permittivity (Class 2)	BJ, B7, C6,C7 : ±10% or ±20%, F : -20%/+80%														

[Test Methods and Remarks]

	Class 1		Class 2	
	Standard	High Frequency Type	C≤10μF	C>10μF
Preconditioning	None		Thermal treatment (at 150°C for 1hr) Note 2	
Measuring frequency	1MHz±10%		1k Hz±10%	120±10Hz
Measuring voltage Note 1	0.5 to 5Vrms		1±0.2Vrms	0.5±0.1Vrms
Bias application	None			

7. Q or Dissipation Factor

Specified Value	Temperature Compensating (Class 1)	Standard	C<30 pF : Q≥400+20C, C≥30 pF : Q≥1000 (C : Nominal capacitance)
	High Permittivity (Class 2) Note 1	High Frequency Type	Refer to detailed specification BJ, B7, C6,C7 : 2.5% max., F : 7% max.

[Test Methods and Remarks]

	Class 1		Class 2	
	Standard	High Frequency Type	C≤10μF	C>10μF
Preconditioning	None		Thermal treatment (at 150°C for 1hr) Note 2	
Measuring frequency	1MHz±10%	1GHz	1k Hz±10%	120±10Hz
Measuring voltage Note 1	0.5 to 5Vrms		1±0.2Vrms	0.5±0.1Vrms
Bias application	None			

High Frequency Type
Measuring equipment: HP4291A
Measuring jig: HP16192A

* This catalog contains the typical specification only due to the limitation of space. When you consider the purchase of our products, please check our specification. For details of each product (characteristics graph, reliability information, precautions for use, and so on), see our Web site (<http://www.ty-top.com/>) or CD catalogs.

RELIABILITY DATA

8. Temperature Characteristic (Without voltage application)

Specified Value	Temperature Compensating (Class 1)	Standard	Temperature Characteristic [ppm/°C]		Tolerance H±60 J±120 K±250		
		High Frequency Type	C□ : 0	CH, CJ, CK			
			R□ : -220	RH			
			S□ : -330	SH, SJ, SK			
			T□ : -470	TJ, TK			
			U□ : -750	UJ, UK			
			SL : +350 to -1000				
Specified Value	High Permittivity (Class 2)		Specification	Capacitance change	Reference temperature	Temperature Range	
		BJ	B		±10%	20°C	-25 to +85°C
			X5R		±15%	25°C	-55 to +85°C
		B7	X7R		±15%	25°C	-55 to +125°C
			X6S		±22%	25°C	-55 to +105°C
		C7	X7S		±22%	25°C	-55 to +125°C
			F		+30/-80%	20°C	-25 to +85°C
		Y5V		+22/-82%	25°C	-30 to +85°C	

[Test Methods and Remarks]

Class 1

Capacitance at 20°C and 85°C shall be measured in thermal equilibrium, and the temperature characteristic shall be calculated from the following equation.

$$\frac{(C_{85}-C_{20})}{C_{20}} \times 10^6 \text{ (ppm/°C)} \quad \Delta T=65$$

Class 2

Capacitance at each step shall be measured in thermal equilibrium, and the temperature characteristic shall be calculated from the following equation.

Step	B, F	X5R, X7R, X6S, X7S, Y5V	$\frac{(C-C_2)}{C_2} \times 100 (\%)$
1	Minimum operating temperature		
2	20°C	25°C	
3	Maximum operating temperature		

C : Capacitance in Step 1 or Step 3
C₂ : Capacitance in Step 2

9. Deflection

Specified Value	Temperature Compensating (Class 1)	Standard	Appearance : No abnormality Capacitance change : Within ±5% or ±0.5 pF, whichever is larger.
		High Frequency Type	Appearance : No abnormality Capacitance change : Within ±0.5 pF
	High Permittivity (Class 2)		Appearance : No abnormality Capacitance change : Within ±12.5% (BJ, B7, C6, C7), Within ±30% (F)

[Test Methods and Remarks]

Multilayer Ceramic Capacitors

	Board	Thickness	Warp	Duration
042, 063 Type	glass epoxy-resin substrate	0.8mm	1mm	10 sec.
The other types		1.6mm		

Array Type

	Board	Thickness	Warp	Duration
096, 110, 212 Type	glass epoxy-resin substrate	1.6mm	1mm	10 sec.

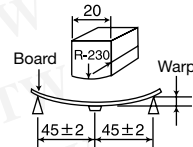

Capacitance measurement shall be conducted with the board bent (Unit: mm)

10. Body Strength

Specified Value	Temperature Compensating (Class 1)	Standard	—
		High Frequency Type	No mechanical damage.
	High Permittivity (Class 2)		—

[Test Methods and Remarks]

High Frequency Type

Applied force: 5N
Duration: 10 sec.

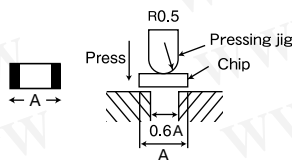

勝特力材料 886-3-5753170
勝特力电子(上海) 86-21-34970699
勝特力电子(深圳) 86-755-83298787
[Http://www.100y.com.tw](http://www.100y.com.tw)

11. Adhesive Strength of Terminal Electrodes

Specified Value	Temperature Compensating (Class 1)	Standard	No terminal separation or its indication.
		High Frequency Type	
	High Permittivity (Class 2)		

[Test Methods and Remarks]

Multilayer Ceramic Capacitors

	Applied force	Duration
042, 063 Type	2N	30±5 sec.
105 Type or more	5N	

Array Type

	Applied force	Duration
096 Type	2N	30±5 sec.
110, 212 Type	5N	

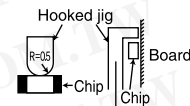

12. Solderability

Specified Value	Temperature Compensating (Class 1)	Standard	At least 95% of terminal electrode is covered by new solder.
		High Frequency Type	
	High Permittivity (Class 2)		

[Test Methods and Remarks]

	Solder type	Solder temperature	Duration
Eutectic solder	H60A or H63A	230±5°C	4±1 sec.
	Lead-free solder	Sn-3.0Ag-0.5Cu	

* This catalog contains the typical specification only due to the limitation of space. When you consider the purchase of our products, please check our specification. For details of each product (characteristics graph, reliability information, precautions for use, and so on), see our Web site (<http://www.ty-top.com/>) or CD catalogs.

RELIABILITY DATA

13. Resistance to Soldering

Specified Value	Temperature Compensating (Class 1)	Standard	Appearance: No abnormality Capacitance change: Within $\pm 2.5\%$ or $\pm 0.25\text{pF}$, whichever is larger. Q: Initial value Insulation resistance: Initial value Withstanding voltage (between terminals): No abnormality
		High Frequency Type	Appearance: No abnormality Capacitance change: Within $\pm 2.5\%$ Q: Initial value Insulation resistance: Initial value Withstanding voltage (between terminals): No abnormality
	High Permittivity (Class 2) Note 1		Appearance: No abnormality Capacitance change: Within $\pm 7.5\%$ (BJ, B7, C6, C7) Within $\pm 20\%$ (F) Dissipation factor: Initial value Insulation resistance: Initial value Withstanding voltage (between terminals): No abnormality

[Test Methods and Remarks]

Class 1		Class 2			
	042, 063 Type	105 Type Array (096, 110 Type)	042, 063 Type	105, 107, 212 Type Array (096, 110, 212 Type)	316, 325 Type
Preconditioning	None		Thermal treatment (at 150°C for 1 hr) Note 2		
Preheating	150°C, 1 to 2 min.	80 to 100°C, 2 to 5 min. 150 to 200°C, 2 to 5 min.	150°C, 1 to 2 min.	80 to 100°C, 2 to 5 min. 150 to 200°C, 2 to 5 min.	80 to 100°C, 5 to 10 min. 150 to 200°C, 5 to 10 min.
Solder temp.	270 \pm 5°C		270 \pm 5°C		
Duration	3 \pm 0.5 sec.		3 \pm 0.5 sec.		
Recovery	6 to 24 hrs (Standard condition) Note 5		24 \pm 2 hrs (Standard condition) Note 5		

14. Temperature Cycle (Thermal Shock)

Specified Value	Temperature Compensating (Class 1)	Standard	Appearance: No abnormality Capacitance change: Within $\pm 2.5\%$ or $\pm 0.25\text{pF}$, whichever is larger. Q: Initial value Insulation resistance: Initial value Withstanding voltage (between terminals): No abnormality
		High Frequency Type	Appearance: No abnormality Capacitance change: Within $\pm 0.25\text{pF}$ Q: Initial value Insulation resistance: Initial value Withstanding voltage (between terminals): No abnormality
	High Permittivity (Class 2) Note 1		Appearance: No abnormality Capacitance change: Within $\pm 7.5\%$ (BJ, B7, C6, C7) Within $\pm 20\%$ (F) Dissipation factor: Initial value Insulation resistance: Initial value Withstanding voltage (between terminals): No abnormality

[Test Methods and Remarks]

	Class 1		Class 2	
	Preconditioning	None		Thermal treatment (at 150°C for 1 hr) Note 2
1 cycle	Step	Temperature (°C)		Time (min.)
	1	Lowest operating temperature +0/-3		30 \pm 3
	2	Normal temperature		2 to 3
	3	Highest operating temperature +0/-3		30 \pm 3
	4	Normal temperature		2 to 3
Number of cycles	5 times			
Recovery	6 to 24 hrs (Standard condition) Note 5		24 \pm 2 hrs (Standard condition) Note 5	

勝特力材料 886-3-5753170
勝特力电子(上海) 86-21-34970699
勝特力电子(深圳) 86-755-83298787
[Http://www.100y.com.tw](http://www.100y.com.tw)

15. Humidity (Steady State)

Specified Value	Temperature Compensating (Class 1)	Standard	Appearance: No abnormality Capacitance change: Within $\pm 5\%$ or $\pm 0.5\text{pF}$, whichever is larger. Q: $C < 10\text{pF}$: $Q \geq 200+10C$ $10 \leq C < 30\text{pF}$: $Q \geq 275+2.5C$ $C \geq 30\text{pF}$: $Q \geq 350$ (C: Nominal capacitance) Insulation resistance: 1000 M Ω min.
		High Frequency Type	Appearance: No abnormality Capacitance change: Within $\pm 0.5\text{pF}$ Insulation resistance: 1000 M Ω min.
	High Permittivity (Class 2) Note 1		Appearance: No abnormality Capacitance change: Within $\pm 12.5\%$ (BJ, B7, C6, C7) Within $\pm 30\%$ (F) Dissipation factor: 5.0% max. (BJ, B7, C6, C7) 11.0% max. (F) Insulation resistance: 50 M $\Omega\mu\text{F}$ or 1000 M Ω whichever is smaller.

[Test Methods and Remarks]

Class 1			Class 2	
	Standard	High Frequency Type	All items	
Preconditioning	None		Preconditioning	Thermal treatment (at 150°C for 1 hr) Note 2
Temperature	40 \pm 2°C	60 \pm 2°C	Temperature	40 \pm 2°C
Humidity	90 to 95%RH		Humidity	90 to 95%RH
Duration	500+24/-0 hrs		Duration	500+24/-0 hrs
Recovery	6 to 24 hrs (Standard condition) Note 5		Recovery	24 \pm 2 hrs (Standard condition) Note 5

* This catalog contains the typical specification only due to the limitation of space. When you consider the purchase of our products, please check our specification. For details of each product (characteristics graph, reliability information, precautions for use, and so on), see our Web site (<http://www.ty-top.com/>) or CD catalogs.

RELIABILITY DATA

16. Humidity Loading			
Specified Value	Temperature Compensating (Class 1)	Standard	Appearance: No abnormality Capacitance change: Within $\pm 7.5\%$ or $\pm 0.75\text{pF}$, whichever is larger. Q : $C < 30\text{pF} : Q \geq 100 + 10C/3$ $C \geq 30\text{pF} : Q \geq 200$ (C : Nominal capacitance) Insulation resistance: 500 MΩ min.
		High Frequency Type	Appearance: No abnormality Capacitance change: $C \leq 2\text{pF} : \text{Within } \pm 0.4 \text{ pF}$ $C > 2\text{pF} : \text{Within } \pm 0.75 \text{ pF}$ (C : Nominal capacitance) Insulation resistance: 500 MΩ min.
	High Permittivity (Class 2) Note 1	Appearance: No abnormality Capacitance change: Within $\pm 12.5\%$ (BJ, B7, C6, C7) Within $\pm 30\%$ (F) Dissipation factor : 5.0% max. (BJ, B7, C6, C7) 11.0% max. (F) Insulation resistance: 25 MΩμF or 500 MΩ, whichever is smaller.	

[Test Methods and Remarks]

Class 1

	Standard	High Frequency Type
Preconditioning	None	
Temperature	40±2°C	60±2°C
Humidity	90 to 95%RH	
Duration	500+24/-0 hrs	
Applied voltage	Rated voltage	
Charge/discharge current	50mA max.	
Recovery	6 to 24 hrs (Standard condition) Note 5	

Class 2

	All items
Preconditioning	Voltage treatment (Rated voltage are applied for 1 hour at 40°C) Note 3
Temperature	40±2°C
Humidity	90 to 95%RH
Duration	500+24/-0 hrs
Applied voltage	Rated voltage
Charge/discharge current	50mA max.
Recovery	24±2 hrs (Standard condition) Note 5

17. High Temperature Loading			
Specified Value	Temperature Compensating (Class 1)	Standard	Appearance: No abnormality Capacitance change: Within $\pm 3\%$ or $\pm 0.3\text{pF}$, whichever is larger. Q : $C < 10\text{pF} : Q \geq 200 + 10C$ $10 \leq C < 30\text{pF} : Q \geq 275 + 2.5C$ $C \geq 30\text{pF} : Q \geq 350$ (C : Nominal capacitance) Insulation resistance: 1000 MΩ min.
		High Frequency Type	Appearance: No abnormality Capacitance change: Within $\pm 3\%$ or $\pm 0.3\text{pF}$, whichever is larger. Insulation resistance: 1000 MΩ min.
	High Permittivity (Class 2) Note 1	Appearance: No abnormality Capacitance change: Within $\pm 12.5\%$ (BJ, B7, C6, C7) Within $\pm 30\%$ (F) Dissipation factor : 5.0% max. (BJ, B7, C6, C7) 11.0% max. (F) Insulation resistance: 50 MΩμF or 1000 MΩ, whichever is smaller.	

[Test Methods and Remarks]

Class 1

	Standard	High Frequency Type
Preconditioning	None	
Temperature	125±3°C	
Duration	1000+48/-0 hrs	
Applied voltage	Rated voltage×2	
Charge/discharge current	50mA max.	
Recovery	6 to 24hr (Standard condition) Note 5	

Class 2

	BJ, F	C6	B7, C7
Preconditioning	Voltage treatment (Twice the rated voltage shall be applied for 1 hour at 85°C, 105°C or 125°C) Note 3, 4		
Temperature	85±2°C	105±3°C	125±3°C
Duration	1000+48/-0 hrs		
Applied voltage	Rated voltage×2 Note 4		
Charge/discharge current	50mA max.		
Recovery	24±2 hrs (Standard condition) Note 5		

Note 1 The figures indicate typical specifications. Please refer to individual specifications in detail.

Note 2 Thermal treatment : Initial value shall be measured after test sample is heat-treated at 150+0/-10°C for an hour and kept at room temperature for 24±2hours.

Note 3 Voltage treatment : Initial value shall be measured after test sample is voltage-treated for an hour at both the temperature and voltage specified in the test conditions, and kept at room temperature for 24±2hours.

Note 4 150% of rated voltage is applicable to some items. Please refer to their specifications for further information.

Note 5 Standard condition: Temperature: 5 to 35°C, Relative humidity: 45 to 85 % RH, Air pressure: 86 to 106kPa

When there are questions concerning measurement results, in order to provide correlation data, the test shall be conducted under the following condition.

Temperature: 20±2°C, Relative humidity: 60 to 70 % RH, Air pressure: 86 to 106kPa

Unless otherwise specified, all the tests are conducted under the "standard condition".

勝特力材料 886-3-5753170
勝特力电子(上海) 86-21-34970699
勝特力电子(深圳) 86-755-83298787
Http://www.100y.com.tw

* This catalog contains the typical specification only due to the limitation of space. When you consider the purchase of our products, please check our specification. For details of each product (characteristics graph, reliability information, precautions for use, and so on), see our Web site (<http://www.ty-top.com/>) or CD catalogs.

PRECAUTIONS

Precautions on the use of Multilayer Ceramic Capacitors

1. Circuit Design

- ◆ Verification of operating environment, electrical rating and performance
 1. A malfunction of equipment in fields such as medical, aerospace, nuclear control, etc. may cause serious harm to human life or have severe social ramifications. Therefore, any capacitors to be used in such equipment may require higher safety and reliability, and shall be clearly differentiated from them used in general purpose applications.
- ◆ Operating Voltage (Verification of Rated voltage)
 1. The operating voltage for capacitors must always be their rated voltage or less.
 If an AC voltage is loaded on a DC voltage, the sum of the two peak voltages shall be the rated voltage or less.
 For a circuit where an AC or a pulse voltage may be used, the sum of their peak voltages shall also be the rated voltage or less.
2. Even if an applied voltage is the rated voltage or less reliability of capacitors may be deteriorated in case that either a high frequency AC voltage or a pulse voltage having rapid rise time is used in a circuit.

2. PCB Design

- ◆ Pattern configurations (Design of Land-patterns)
 1. When capacitors are mounted on PCBs, the amount of solder used (size of fillet) can directly affect the capacitor performance. Therefore, the following items must be carefully considered in the design of land patterns:
 (1) Excessive solder applied can cause mechanical stresses which lead to chip breaking or cracking. Therefore, please consider appropriate land-patterns for proper amount of solder.
 (2) When more than one component are jointly soldered onto the same land, each component's soldering point shall be separated by solder-resist.
- ◆ Pattern configurations (Capacitor layout on PCBs)
 After capacitors are mounted on boards, they can be subjected to mechanical stresses in subsequent manufacturing processes (PCB cutting, board inspection, mounting of additional parts, assembly into the chassis, wave soldering of the boards, etc.). For this reason, land pattern configurations and positions of capacitors shall be carefully considered to minimize stresses.

- ◆ Pattern configurations (Design of Land-patterns)
 The following diagrams and tables show some examples of recommended land patterns to prevent excessive solder amounts.

(1) Recommended land dimensions for typical chip capacitors

- Multilayer Ceramic Capacitors : Recommended land dimensions (unit: mm)
 Wave-soldering

Type	107	212	316	325
Size	L	1.6	2.0	3.2
	W	0.8	1.25	1.6
A	0.8 to 1.0	1.0 to 1.4	1.8 to 2.5	1.8 to 2.5
B	0.5 to 0.8	0.8 to 1.5	0.8 to 1.7	0.8 to 1.7
C	0.6 to 0.8	0.9 to 1.2	1.2 to 1.6	1.8 to 2.5

Reflow-soldering

Type	042	063	105	107	212	316	325	432
Size	L	0.4	0.6	1.0	1.6	2.0	3.2	4.5
	W	0.2	0.3	0.5	0.8	1.25	1.6	2.5
A	0.15 to 0.25	0.20 to 0.30	0.45 to 0.55	0.8 to 1.0	0.8 to 1.2	1.8 to 2.5	1.8 to 2.5	2.5 to 3.5
B	0.15 to 0.20	0.20 to 0.30	0.40 to 0.50	0.6 to 0.8	0.8 to 1.2	1.0 to 1.5	1.0 to 1.5	1.5 to 1.8
C	0.15 to 0.30	0.25 to 0.40	0.45 to 0.55	0.6 to 0.8	0.9 to 1.6	1.2 to 2.0	1.8 to 3.2	2.3 to 3.5

Note : Recommended land size might be different according to the allowance of the size of the product.

- LWDC: Recommended land dimensions for reflow-soldering (unit: mm)

Type	105	107	212
Size	L	0.52	0.8
	W	1.0	1.6
A	0.18 to 0.22	0.25 to 0.3	0.5 to 0.7
B	0.2 to 0.25	0.3 to 0.4	0.4 to 0.5
C	0.9 to 1.1	1.5 to 1.7	1.9 to 2.1

- Array type: Recommended land dimensions for reflow-soldering (unit: mm)

Type	096 (2 circuits)	110 (2 circuits)	212 (2 circuits)	212 (4 circuits)
Size	L	0.9	1.37	2.0
	W	0.6	1.0	1.25
a	0.25 to 0.35	0.35 to 0.45	0.5 to 0.6	0.5 to 0.6
b	0.15 to 0.25	0.55 to 0.65	0.5 to 0.6	0.5 to 0.6
c	0.15 to 0.25	0.3 to 0.4	0.5 to 0.6	0.2 to 0.3
d	0.45	0.64	1.0	0.5

(2) Examples of good and bad solder application

Items	Not recommended	Recommended
Mixed mounting of SMD and leaded components	 Lead wire of component	 Solder-resist
Component placement close to the chassis	 Chassis Solder (for grounding) Land	 Solder-resist
Hand-soldering of leaded components near mounted components	 Lead wire of component Soldering iron	 Solder-resist
Horizontal component placement	 Solder-resist	 Solder-resist

Land patterns for PCBs

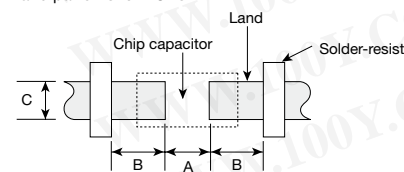

Chip capacitor



LWDC

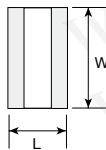

2 circuits

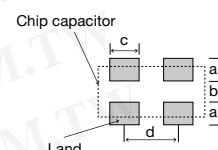

4 circuits

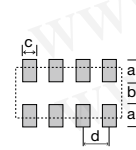

Technical considerations

勝特力材料 886-3-5753170
 勝特力电子(上海) 86-21-34970699
 勝特力电子(深圳) 86-755-83298787
[Http://www.100y.com.tw](http://www.100y.com.tw)

To next page

* This catalog contains the typical specification only due to the limitation of space. When you consider the purchase of our products, please check our specification. For details of each product (characteristics graph, reliability information, precautions for use, and so on), see our Web site (<http://www.ty-top.com/>) or CD catalogs.

PRECAUTIONS

Precautions on the use of Multilayer Ceramic Capacitors

2. PCB Design

◆Pattern configurations (Capacitor layout on PCBs)

1-1. The following is examples of good and bad capacitor layouts ; capacitors shall be located to minimize any possible mechanical stresses from board warp or deflection.

Items	Not recommended	Recommended
Deflection of board		 Position the component at a right angle to the direction of the mechanical stresses that are anticipated.

Technical considerations

1-2. The amount of mechanical stresses given will vary depending on capacitor layout. Please refer to diagram below.

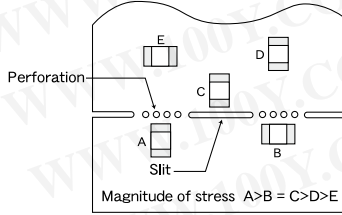

1-3. When PCB is split, the amount of mechanical stress on the capacitors can vary according to the method used. The following methods are listed in order from least stressful to most stressful: push-back, slit, V-grooving, and perforation. Thus, please consider the PCB, split methods as well as chip location.

勝特力材料 886-3-5753170
 勝特力电子(上海) 86-21-34970699
 勝特力电子(深圳) 86-755-83298787
[Http://www.100y.com.tw](http://www.100y.com.tw)

3. Mounting

◆Adjustment of mounting machine

- When capacitors are mounted on PCB, excessive impact load shall not be imposed on them.
- Maintenance and inspection of mounting machines shall be conducted periodically.

Precautions

◆Selection of Adhesives

1. When chips are attached on PCBs with adhesives prior to soldering, it may cause capacitor characteristics degradation unless the following factors are appropriately checked : size of land patterns, type of adhesive, amount applied, hardening temperature and hardening period. Therefore, please contact us for further information.

◆Adjustment of mounting machine

1. When the bottom dead center of a pick-up nozzle is too low, excessive force is imposed on capacitors and causes damages. To avoid this, the following points shall be considerable.

- The bottom dead center of the pick-up nozzle shall be adjusted to the surface level of PCB without the board deflection.
- The pressure of nozzle shall be adjusted between 1 and 3 N static loads.
- To reduce the amount of deflection of the board caused by impact of the pick-up nozzle, supporting pins or back-up pins shall be used on the other side of the PCB. The following diagrams show some typical examples of good and bad pick-up nozzle placement:

Items	Not recommended	Recommended
Single-sided mounting		
Double-sided mounting		

Technical considerations

2. As the alignment pin is worn out, adjustment of the nozzle height can cause chipping or cracking of capacitors because of mechanical impact on the capacitors. To avoid this, the monitoring of the width between the alignment pins in the stopped position, maintenance, check and replacement of the pin shall be conducted periodically.

◆Selection of Adhesives

Some adhesives may cause IR deterioration. The different shrinkage percentage of between the adhesive and the capacitors may result in stresses on the capacitors and lead to cracking. Moreover, too little or too much adhesive applied to the board may adversely affect components. Therefore, the following precautions shall be noted in the application of adhesives.

(1) Required adhesive characteristics

- The adhesive shall be strong enough to hold parts on the board during the mounting & solder process.
- The adhesive shall have sufficient strength at high temperatures.
- The adhesive shall have good coating and thickness consistency.
- The adhesive shall be used during its prescribed shelf life.
- The adhesive shall harden rapidly.
- The adhesive shall have corrosion resistance.
- The adhesive shall have excellent insulation characteristics.
- The adhesive shall have no emission of toxic gasses and no effect on the human body.

(2) The recommended amount of adhesives is as follows;

[Recommended condition]

Figure	212/316 case sizes as examples
a	0.3mm min
b	100 to 120 μ m
c	Adhesives shall not contact land

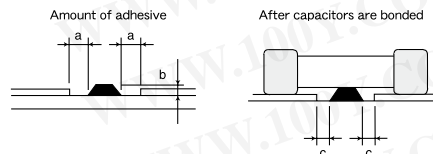

* This catalog contains the typical specification only due to the limitation of space. When you consider the purchase of our products, please check our specification. For details of each product (characteristics graph, reliability information, precautions for use, and so on), see our Web site (<http://www.ty-top.com/>) or CD catalogs.

PRECAUTIONS

Precautions on the use of Multilayer Ceramic Capacitors

4. Soldering

◆ Selection of Flux
 Since flux may have a significant effect on the performance of capacitors, it is necessary to verify the following conditions prior to use:
 (1) Flux used shall be less than or equal to 0.1 wt% (in Cl equivalent) of halogenated content. Flux having a strong acidity content shall not be applied.
 (2) When shall capacitors are soldered on boards, the amount of flux applied shall be controlled at the optimum level.
 (3) When water-soluble flux is used, special care shall be taken to properly clean the boards.

◆ Soldering
 Temperature, time, amount of solder, etc. shall be set in accordance with their recommended conditions.
 Sn-Zn solder paste can adversely affect MLCC reliability.
 Please contact us prior to usage of Sn-Zn solder.

◆ Selection of Flux
 1-1. When too much halogenated substance (Chlorine, etc.) content is used to activate flux, or highly acidic flux is used, it may lead to corrosion of terminal electrodes or degradation of insulation resistance on the surfaces of the capacitors.
 1-2. Flux is used to increase solderability in wave soldering. However if too much flux is applied, a large amount of flux gas may be emitted and may adversely affect the solderability. To minimize the amount of flux applied, it is recommended to use a flux-bubbling system.
 1-3. Since the residue of water-soluble flux is easily dissolved in moisture in the air, the residues on the surfaces of capacitors in high humidity conditions may cause a degradation of insulation resistance and reliability of the capacitors. Therefore, the cleaning methods and the capability of the machines used shall also be considered carefully when water-soluble flux is used.

◆ Soldering
 • Ceramic chip capacitors are susceptible to thermal shock when exposed to rapid or concentrated heating or rapid cooling.
 • Therefore, the soldering must be conducted with great care so as to prevent malfunction of the components due to excessive thermal shock.
 • Preheating : Capacitors shall be preheated sufficiently, and the temperature difference between the capacitors and solder shall be within 100 to 130°C.
 • Cooling : The temperature difference between the capacitors and cleaning process shall not be greater than 100°C.

[Reflow soldering]

[Recommended conditions for eutectic soldering]

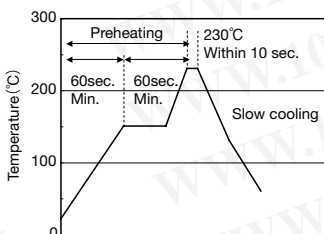

[Recommended condition for Pb-free soldering]

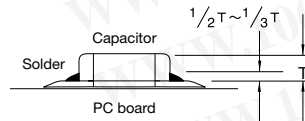
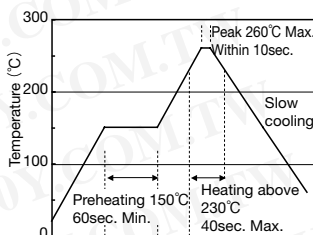

Caution

- ① The ideal condition is to have solder mass (fillet) controlled to 1/2 to 1/3 of the thickness of a capacitor.
- ② Because excessive dwell times can adversely affect solderability, soldering duration shall be kept as close to recommended times as possible.

Technical considerations

[Wave soldering]

[Recommended conditions for eutectic soldering]

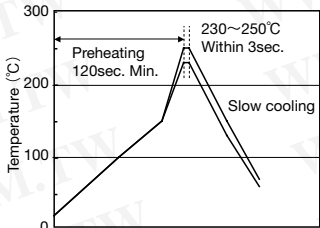

[Recommended condition for Pb-free soldering]

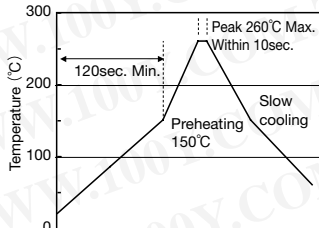

Caution

- ① Wave soldering must not be applied to capacitors designated as for reflow soldering only.

[Hand soldering]

[Recommended conditions for eutectic soldering]

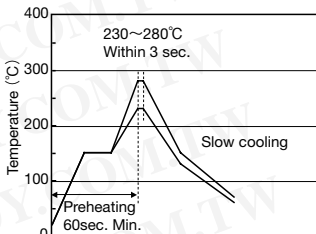

[Recommended condition for Pb-free soldering]

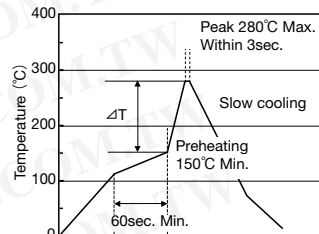
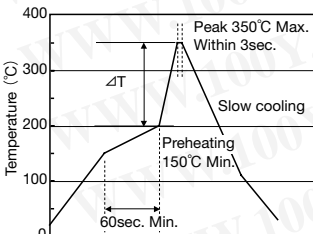

Caution

- ① Use a 50W soldering iron with a maximum tip diameter of 1.0 mm.
- ② The soldering iron shall not directly touch capacitors.

勝特力材料 886-3-5753170
 勝特力电子(上海) 86-21-34970699
 勝特力电子(深圳) 86-755-83298787
[Http://www.100y.com.tw](http://www.100y.com.tw)

* This catalog contains the typical specification only due to the limitation of space. When you consider the purchase of our products, please check our specification. For details of each product (characteristics graph, reliability information, precautions for use, and so on), see our Web site (<http://www.ty-top.com/>) or CD catalogs.

PRECAUTIONS

Precautions on the use of Multilayer Ceramic Capacitors

5. Cleaning	
Precautions	<p>◆Cleaning conditions</p> <ol style="list-style-type: none">When PCBs are cleaned after capacitors mounting, please select the appropriate cleaning solution in accordance with the intended use of the cleaning. (e.g. to remove soldering flux or other materials from the production process.)Cleaning condition shall be determined after it is verified by using actual cleaning machine that the cleaning process does not affect capacitor's characteristics.
Technical considerations	<ol style="list-style-type: none">The use of inappropriate cleaning solutions can cause foreign substances such as flux residue to adhere to capacitors or deteriorate their outer coating, resulting in a degradation of the capacitor's electrical properties (especially insulation resistance).Inappropriate cleaning conditions (insufficient or excessive cleaning) may adversely affect the performance of the capacitors. In the case of ultrasonic cleaning, too much power output can cause excessive vibration of PCBs which may lead to the cracking of capacitors or the soldered portion, or decrease the terminal electrodes' strength. Therefore, the following conditions shall be carefully checked; Ultrasonic output : 20 W/l or less Ultrasonic frequency : 40 kHz or less Ultrasonic washing period : 5 min. or less
6. Resin coating and mold	
Precautions	<ol style="list-style-type: none">With some type of resins, decomposition gas or chemical reaction vapor may remain inside the resin during the hardening period or while left under normal storage conditions resulting in the deterioration of the capacitor's performance.When a resin's hardening temperature is higher than capacitor's operating temperature, the stresses generated by the excessive heat may lead to damage or destruction of capacitors. The use of such resins, molding materials etc. is not recommended.
7. Handling	
Precautions	<p>◆Splitting of PCB</p> <ol style="list-style-type: none">When PCBs are split after components mounting, care shall be taken so as not to give any stresses of deflection or twisting to the board.Board separation shall not be done manually, but by using the appropriate devices. <p>◆Mechanical considerations</p> <p>Be careful not to subject capacitors to excessive mechanical shocks.</p> <ol style="list-style-type: none">If ceramic capacitors are dropped onto a floor or a hard surface, they shall not be used.Please be careful that the mounted components do not come in contact with or bump against other boards or components.
8. Storage conditions	
Precautions	<p>◆Storage</p> <ol style="list-style-type: none">To maintain the solderability of terminal electrodes and to keep packaging materials in good condition, care must be taken to control temperature and humidity in the storage area. Humidity should especially be kept as low as possible. ·Recommended conditions Ambient temperature : Below 30°C Humidity : Below 70% RH The ambient temperature must be kept below 40°C. Even under ideal storage conditions, solderability of capacitor is deteriorated as time passes, so capacitors shall be used within 6 months from the time of delivery. ·Ceramic chip capacitors shall be kept where no chlorine or sulfur exists in the air.The capacitance values of high dielectric constant capacitors will gradually decrease with the passage of time, so care shall be taken to design circuits. Even if capacitance value decreases as time passes, it will get back to the initial value by a heat treatment at 150°C for 1hour.
Technical considerations	<p>If capacitors are stored in a high temperature and humidity environment, it might rapidly cause poor solderability due to terminal oxidation and quality loss of taping/packaging materials. For this reason, capacitors shall be used within 6 months from the time of delivery. If exceeding the above period, please check solderability before using the capacitors.</p>

※RCR-2335B (Safety Application Guide for fixed ceramic capacitors for use in electronic equipment) is published by JEITA.
Please check the guide regarding precautions for deflection test, soldering by spot heat, and so on.

勝特力材料 886-3-5753170
勝特力电子(上海) 86-21-34970699
勝特力电子(深圳) 86-755-83298787
[Http://www.100y.com.tw](http://www.100y.com.tw)