

AR- / AR- HG SERIES

ALUMINIUM ELECTROLYTIC CAPACITORS GENERAL PURPOSE

Series	Capacitance range	Voltage Range	Temperature range	Case $\Phi \times H$	Applications
AR / ARU	100 - 470000	25 - 450	-40 °C , +85°C	35 x 59	High capacitance, reduced volume, long life, industrial applications
AR-HG ARU-HG				76 x 147	High CV product for applications where dimensions are very important

MECHANICAL OUTLINES:

CASE: aluminium made

TERMINALS: screw

SEALING: hermetic by beading on an EPR gasket, housed on a resin cover

PRESSURE RELEASE VENT: made in silicone-rubber

SLEEVE: self-extinguishing thermoshrinkable sleeve

SIZE: see enclosed drawings

MOUNTING HARDWARE: see hardware section

SPECIFICATIONS	TEMPERATURE RANGE	CAPACITANCE
CECC 30300 IEC 384-4 ("long life grade") MIL C62D DIN 41240 / DIN 45910	Operating: -40 °C/ +85 °C Climatic category : 40/85/56	Tolerance shall be within the following limits: <ul style="list-style-type: none"> • standard tolerance -10% +30% • or available on request -20% +20%

LEAKAGE CURRENT:

After the rated voltage has been applied to the capacitor for 5 minutes the leakage current must be:

Maximum limit	at 25 °C	$I_f \leq 0,004 * C * V$
Operating limit	at 25 °C:	$I_f \leq 0,001 * C * V$

where I_f = leakage current (μA)

C = capacitance (μF)

V = rated voltage (V)

IMPORTANT

- When using high-capacitance and high-voltage electrolytic capacitors it is important to remember that the inner part (the rolled section) is not insulated from can: between the negative pole and the aluminium can there is a variable and not defined resistance essentially due to the electrolyte used in capacitor manufacture.

SURGE VOLTAGE

Working Voltage	25	40	50	63	75	100	160	200	250	350	400	420	450
Surge Voltage	29	46	58	73	86	115	185	230	290	385	440	460	495

RIPPLE CURRENT:

The allowable values of ripple current in amperes, are related to the temperature and frequency by the formula:

$$I_{rip} = K_t \cdot K_f \cdot I_{r85}$$

where I_{r85} is the limit given by tables, referred to a temperature of 85 °C and to a frequency of 100 HZ and K_t or K_f are values here below tabulated:

Note . Ripple current is function of the capacitance tolerance

°C	40	55	65	75	85
K_t	2.1	1.8	1.6	1.3	1.0

	K_f					
V_n	V=50	50<V=300	V>300	V=50	50<V=300	V>300
Hz	Code Diameter A,B			Code Diameter C,D		
50	0.82	0.79	0.76	0.86	0.78	0.72
100	1	1	1	1	1	1
120	1.03	1.04	1.04	1.01	1.02	1.03
300	1.12	1.16	1.28	1.03	1.08	1.24
500	1.15	1.22	1.39	1.03	1.09	1.32
>1000	1.18	1.25	1.45	1.03	1.09	1.37

DIMENSIONS

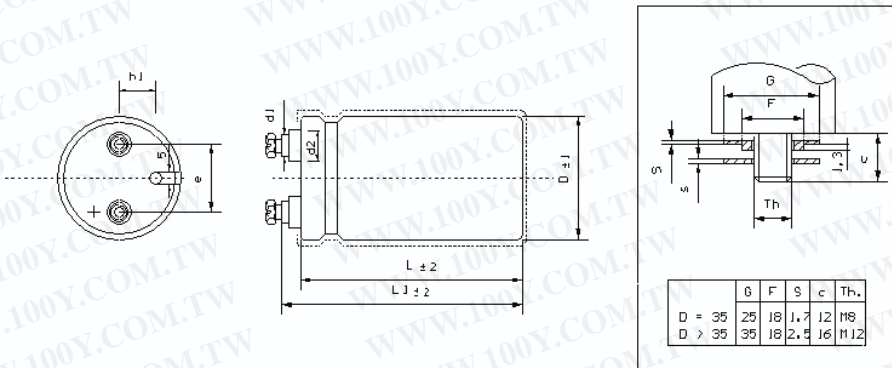

Insert screw thread = m5	Screw torque for hex nuts m8 = 4 Nm.
Insert screw torque max. (m5) = 2 Nm.	Screw torque for hex nuts m12 = 10 Nm
Insert screw length (terminal code "-x") = 10 mm.	

CASE CODE	Φ X L (mm)	l1	d1 ±0.5	d2 ±0.5	h1	e	CASE CODE	Φ X L (mm)	l1	d1 ±0.5	d2 ±0.5	h1	e
AA	35 x 59	65	8	12	8	12,7	CC	63 x 107	111	13	18	16	28,6
AB	35 X 83	89	8	12	8	12,7							
AC	35 X 105	109	8	12	8	12,7	DC	76 x 107	111	13	18	19	31,8
BB	51 x 83	89	13	18	13	22,2							
BC	51 x 105	109	13	18	13	22,2	DF	76 x 147	151	13	18	19	31,8

STANDARD MOUNTING STUD HARDWARE - INSULATING PLASTIC WASHER AND METALLIC NUT

EXPECTED LIFE VS. TEMPERATURE AND RIPPLE CURRENT

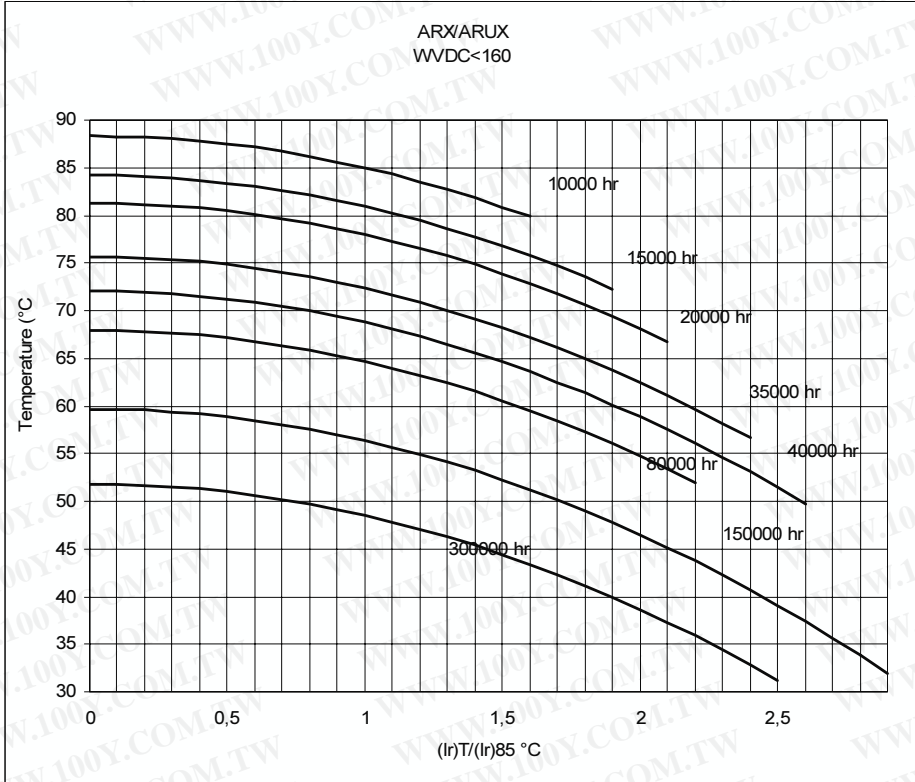

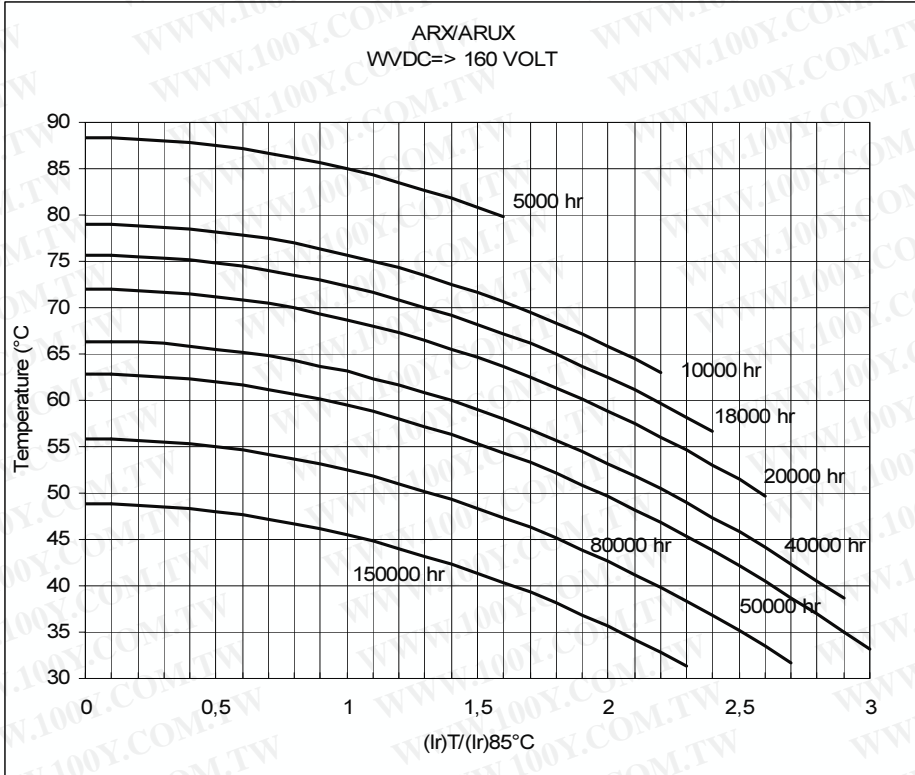

Expected life criteria: see introduction

ARX / ARUX

CAP (μ F)	Rated Voltage (Vn)	Case Code	Φ x h (mm)	TG δ 100Hz	ESR	ESR	Z	I ripple	I ripple	CATALOGUE NUMBER	
					max 100Hz (mOhm)	typ 100Hz (mOhm)	max 10KHz (mOhm)	55°C 100Hz (A)	85°C 100Hz (A)	Flat bottom	Mounting stud
10000	25	AA	35 x 59	0,27	39	31	27	8,4	4,6	ARX103X025AA1	ARUX103X025AA1
15000		AB	35 x 79	0,30	29	23	21	11,9	6,6	ARX153X025AB1	ARUX153X025AB1
22000		AC	35 x 105	0,33	21	17	16	15,6	8,7	ARX223X025AC1	ARUX223X025AC1
33000		BB	51 x 83	0,47	20	16	16	17,3	9,6	ARX333X025BB1	ARUX333X025BB1
47000		BC	51 x 105	0,68	21	17	14	19,5	10,8	ARX473X025BC1	ARUX473X025BC1
68000		CC	63 x 107	0,70	15	12	12	26	14,5	ARX683X025CC1	ARUX683X025CC1
100000		CC	63 x 107	0,70	10	8	10	31,5	17,5	ARX104X025CC1	ARUX104X025CC1
150000		DC	76 x 107	0,98	9	7	8	36,3	20,2	ARX154X025DC1	ARUX154X025DC1
220000		DF	76 x 147	1,26	8	7	7	44,4	24,6	ARX224X025DF1	ARUX224X025DF1

CAP (μ F)	Rated Voltage (Vn)	Case Code	Φ x h (mm)	TG δ 100Hz	ESR	ESR	Z	I ripple	I ripple	CATALOGUE NUMBER	
					max 100Hz (mOhm)	typ 100Hz (mOhm)	max 10KHz (mOhm)	55°C 100Hz (A)	85°C 100Hz (A)	Flat bottom	Mounting stud
6800	40	AA	35 x 59	0,22	46	37	33	7,3	4,2	ARX682X040AA1	ARUX682X040AA1
10000		AB	35 x 79	0,22	32	25	22	10,8	6,3	ARX103X040AB1	ARUX103X040AB1
15000		AC	35 x 105	0,28	27	21	15	13,3	7,8	ARX153X040AC1	ARUX153X040AC1
22000		BB	51 x 83	0,36	23	19	16	15,4	9	ARX223X040BB1	ARUX223X040BB1
33000		BC	51 x 105	0,36	16	13	12	21,4	12,5	ARX333X040BC1	ARUX333X040BC1
47000		CC	63 x 107	0,33	10	8	8	30	17,5	ARX473X040CC1	ARUX473X040CC1
68000		CC	63 x 107	0,39	8	7	7	33,2	19,4	ARX683X040CC1	ARUX683X040CC1
100000		DC	76 x 107	0,56	8	6	7	37,4	21,8	ARX104X040DC1	ARUX104X040DC1
150000		DF	76 x 147	0,75	7	6	7	45,2	26,4	ARX154X040DF1	ARUX154X040DF1

CAP (μ F)	Rated Voltage (Vn)	Case Code	Φ x h (mm)	TG δ 100Hz	ESR	ESR	Z	I ripple	I ripple	CATALOGUE NUMBER	
					max 100Hz (mOhm)	typ 100Hz (mOhm)	max 10KHz (mOhm)	55°C 100Hz (A)	85°C 100Hz (A)	Flat bottom	Mounting stud
4700	50	AA	35 x 59	0,18	55	44	39	6,7	3,9	ARX472X050AA1	ARUX472X050AA1
6800		AB	35 x 79	0,21	44	35	29	9,1	5,3	ARX682X050AB1	ARUX682X050AB1
10000		AC	35 x 105	0,25	36	29	25	11,5	6,7	ARX103X050AC1	ARUX103X050AC1
15000		BB	51 x 83	0,27	26	21	17	14,7	8,6	ARX153X050BB1	ARUX153X050BB1
22000		BC	51 x 105	0,33	21	17	14	18,2	10,6	ARX223X050BC1	ARUX223X050BC1
33000		CC	63 x 107	0,35	15	12	10	24,4	14,2	ARX333X050CC1	ARUX333X050CC1
47000		CC	63 x 107	0,37	11	9	9	28,3	16,5	ARX473X050CC1	ARUX473X050CC1
68000		DC	76 x 107	0,42	9	7	8	35,6	20,8	ARX683X050DC1	ARUX683X050DC1
100000		DF	76 x 147	0,49	7	6	6	45,7	26,6	ARX104X050DF1	ARUX104X050DF1

CAP (μF)	Rated Voltage (Vn)	Case Code	$\Phi \times h$ (mm)	TG δ 100Hz	ESR	ESR	Z	I ripple	I ripple	CATALOGUE NUMBER	
					max 100Hz (mOhm)	typ 100Hz (mOhm)	max 10KHz (mOhm)	55°C 100Hz (A)	85°C 100Hz (A)	Flat bottom	Mounting stud
3300	63	AA	35 x 59	0,13	56	45	44	6,6	3,8	ARX332X063AA1	ARUX332X063AA1
4700		AB	35 x 79	0,14	43	34	33	9,3	5,4	ARX472X063AB1	ARUX472X063AB1
6800		AB	35 x 79	0,15	32	25	24	10,8	6,3	ARX682X063AB1	ARUX682X063AB1
10000		AC	35 x 105	0,16	23	18	15	14,4	8,4	ARX103X063AC1	ARUX103X063AC1
10000		BB	51 x 83	0,18	26	21	17	14,7	8,6	ARX103X063BB1	ARUX103X063BB1
15000		BB	51 x 83	0,22	21	17	16	16,3	9,5	ARX153X063BB1	ARUX153X063BB1
22000		BC	51 x 105	0,25	16	13	12	21,0	12,2	ARX223X063BC1	ARUX223X063BC1
33000		CC	63 x 107	0,20	9	7	8	32,3	18,8	ARX333X063CC1	ARUX333X063CC1
47000		DC	76 x 107	0,25	8	6	7	38,4	22,4	ARX473X063DC1	ARUX473X063DC1
68000		DF	76 x 147	0,30	6	5	6	48,1	28,1	ARX683X063DF1	ARUX683X063DF1

CAP (μF)	Rated Voltage (Vn)	Case Code	$\Phi \times h$ (mm)	TG δ 100Hz	ESR	ESR	Z	I ripple	I ripple	CATALOGUE NUMBER	
					max 100Hz (mOhm)	typ 100Hz (mOhm)	max 10KHz (mOhm)	55°C 100Hz (A)	85°C 100Hz (A)	Flat bottom	Mounting stud
3300	75	AA	35 x 59	0,12	52	42	34	6,9	4,0	ARX332X075AA1	ARUX332X075AA1
4700		AB	35 x 79	0,12	37	29	25	10,0	5,8	ARX472X075AB1	ARUX472X075AB1
6800		AC	35 x 105	0,12	25	20	18	13,7	8,0	ARX682X075AC1	ARUX682X075AC1
10000		BB	51 x 83	0,16	23	18	16	15,6	9,1	ARX103X075BB1	ARUX103X075BB1
15000		BC	51 x 105	0,16	15	12	12	21,6	12,6	ARX153X075BC1	ARUX153X075BC1
22000		CC	63 x 107	0,12	8	6	7	34,0	19,0	ARX223X075CC1	ARUX223X075CC1
33000		CC	63 x 107	0,12	5	4	7	36,4	21,4	ARX333X075CC1	ARUX333X075CC1
33000		DC	76 x 107	0,16	7	6	7	40,2	23,4	ARX333X075DC1	ARUX333X075DC1
47000		DC	76 x 107	0,18	5	4	5	45,2	26,4	ARX473X075DC1	ARUX473X075DC1
68000		DF	76 x 147	0,22	5	4	6	56,2	32,8	ARX683X075DF1	ARUX683X075DF1

CAP (μF)	Rated Voltage (Vn)	Case Code	$\Phi \times h$ (mm)	TG δ 100Hz	ESR	ESR	Z	I ripple	I ripple	CATALOGUE NUMBER	
					max 100Hz (mOhm)	typ 100Hz (mOhm)	max 10KHz (mOhm)	55°C 100Hz (A)	85°C 100Hz (A)	Flat bottom	Mounting stud
2200	100	AA	35 x 59	0,10	65	52	42	6,2	3,6	ARX222X100AA1	ARUX222X100AA1
3300		AB	35 x 79	0,10	43	35	30	9,2	5,4	ARX332X100AB1	ARUX332X100AB1
4700		AC	35 x 105	0,08	24	20	20	13,9	8,1	ARX472X100AC1	ARUX472X100AC1
4700		BB	51 x 83	0,10	30	24	21	13,5	7,9	ARX472X100BB1	ARUX472X100BB1
6800		BC	51 x 105	0,12	25	20	20	16,8	9,8	ARX682X100BC1	ARUX682X100BC1
10000		BC	51 x 105	0,10	14	11	10	22,3	13,0	ARX103X100BC1	ARUX103X100BC1
10000		CC	63 x 107	0,10	14	11	10	25,1	14,7	ARX103X100CC1	ARUX103X100CC1
15000		CC	63 x 107	0,11	11	8	7	29,4	17,1	ARX153X100CC1	ARUX153X100CC1
22000		CD	63 x 118	0,13	8	7	6	34,4	20,2	ARX223X100CD1	ARUX223X100CD1
22000		DC	76 x 107	0,14	9	7	6	35,1	20,5	ARX223X100DC1	ARUX223X100DC1
33000		DF	76 x 147	0,16	7	6	5	45,9	26,8	ARX333X100DF1	ARUX333X100DF1

CAP (μ F)	Rated Voltage (Vn)	Case Code	Φ x h (mm)	TG δ 100Hz	ESR	ESR	Z	I ripple	I ripple	CATALOGUE NUMBER	
					max 100Hz (mOhm)	typ 100Hz (mOhm)	max 10KHz (mOhm)	55°C 100Hz (A)	85°C 100Hz (A)	Flat bottom	Mounting stud
680	160	AA	35 x 59	0,10	211	169	127	3,4	2,0	ARX681X160AA1	ARUX681X160AA1
1000		AB	35 x 79	0,10	143	115	89	5,1	2,9	ARX102X160AB1	ARUX102X160AB1
1500		AC	35 x 105	0,10	96	76	62	7,0	4,1	ARX152X160AC1	ARUX152X160AC1
2200		BB	51 x 83	0,10	65	52	42	9,2	5,4	ARX222X160BB1	ARUX222X160BB1
3300		BC	51 x 105	0,12	52	42	36	11,7	6,8	ARX332X160BC1	ARUX332X160BC1
4700		CC	63 x 107	0,12	37	29	25	15,7	9,2	ARX472X160CC1	ARUX472X160CC1
6800		DC	76 x 107	0,12	25	20	18	21,1	12,3	ARX682X160DC1	ARUX682X160DC1
10000		DC	76 x 107	0,12	17	14	12	25,5	14,9	ARX103X160DC1	ARUX103X160DC1
15000		DF	76 x 147	0,13	12	10	9	34,4	20,0	ARX153X160DF1	ARUX153X160DF1

CAP (μ F)	Rated Voltage (Vn)	Case Code	Φ x h (mm)	TG δ 100Hz	ESR	ESR	Z	I ripple	I ripple	CATALOGUE NUMBER	
					max 100Hz (mOhm)	typ 100Hz (mOhm)	max 10KHz (mOhm)	55°C 100Hz (A)	85°C 100Hz (A)	Flat bottom	Mounting stud
470	200	AA	35 x 59	0,09	274	220	178	3,0	1,8	ARX471X200AA1	ARUX471X200AA1
680		AB	35 x 79	0,09	190	152	123	4,4	2,7	ARX681X200AB1	ARUX681X200AB1
1000		AC	35 x 105	0,09	129	103	85	6,1	3,7	ARX102X200AC1	ARUX102X200AC1
1500		BB	51 x 83	0,10	96	76	63	7,6	4,7	ARX152X200BB1	ARUX152X200BB1
2200		BC	51 x 105	0,10	65	52	43	10,5	6,4	ARX222X200BC1	ARUX222X200BC1
3300		CC	63 x 107	0,10	43	35	29	14,4	8,8	ARX332X200CC1	ARUX332X200CC1
4700		DC	76 x 107	0,12	37	29	27	17,5	10,7	ARX472X200DC1	ARUX472X200DC1
6800		DF	76 x 147	0,12	25	20	18	24,1	14,7	ARX682X200DF1	ARUX682X200DF1
10000		DF	76 x 147	0,12	17	14	12	29,2	17,8	ARX103X200DF1	ARUX103X200DF1

CAP (μ F)	Rated Voltage (Vn)	Case Code	Φ x h (mm)	TG δ 100Hz	ESR	ESR	Z	I ripple	I ripple	CATALOGUE NUMBER	
					max 100Hz (mOhm)	typ 100Hz (mOhm)	max 10KHz (mOhm)	55°C 100Hz (A)	85°C 100Hz (A)	Flat bottom	Mounting stud
330	250	AA	35 x 59	0,08	347	278	215	2,7	1,6	ARX331X250AA1	ARUX331X250AA1
470		AB	35 x 79	0,08	244	195	157	3,9	2,3	ARX471X250AB1	ARUX471X250AB1
680		AC	35 x 105	0,08	169	135	108	5,3	3,2	ARX681X250AC1	ARUX681X250AC1
1000		BB	51 x 83	0,08	115	92	73	7,0	4,3	ARX102X250BB1	ARUX102X250BB1
1500		BC	51 x 105	0,08	76	61	51	9,7	5,9	ARX152X250BC1	ARUX152X250BC1
2200		CC	63 x 107	0,08	52	42	35	13,2	8,1	ARX222X250CC1	ARUX222X250CC1
3300		CC	63 x 107	0,09	39	31	27	15,2	9,3	ARX332X250CC1	ARUX332X250CC1
4700		DC	76 x 107	0,10	30	24	21	19,2	11,7	ARX472X250DC1	ARUX472X250DC1
6800		DF	76 x 147	0,10	21	17	14	26,4	16,1	ARX682X250DF1	ARUX682X250DF1

CAP (μ F)	Rated Voltage (Vn)	Case Code	Φ x h (mm)	TG δ 100Hz	ESR	ESR	Z	I ripple	I ripple	CATALOGUE NUMBER	
					max 100Hz (mOhm)	typ 100Hz (mOhm)	max 10Khz (mOhm)	55°C 100Hz (A)	85°C 100Hz (A)	Flat bottom	Mounting stud
220	350	AA	35 x 59	0,07	456	365	280	2,3	1,4	ARX221X350AA1	ARUX221X350AA1
330		AB	35 x 79	0,08	347	278	186	3,2	2,0	ARX331X350AB1	ARUX331X350AB1
470		AC	35 x 105	0,08	244	195	140	4,4	2,7	ARX471X350AC1	ARUX471X350AC1
470		BB	51 x 83	0,08	244	195	143	4,8	2,9	ARX471X350BB1	ARUX471X350BB1
680		BB	51 x 83	0,08	169	135	107	5,7	3,5	ARX681X350BB1	ARUX681X350BB1
1000		BB	51 x 83	0,08	115	92	73	7,0	4,3	ARX102X350BB1	ARUX102X350BB1
1500		BC	51 x 105	0,08	76	61	50	9,7	5,9	ARX152X350BC1	ARUX152X350BC1
2200		CC	63 x 107	0,09	59	47	39	12,4	7,6	ARX222X350CC1	ARUX222X350CC1
2200		CD	63 x 118	0,09	59	47	38	13,5	8,0	ARX222X350CD1	ARUX222X350CD1
3300		DC	76 x 107	0,10	43	35	29	16,1	9,8	ARX332X350DC1	ARUX332X350DC1
3300		DF	76 x 147	0,09	39	31	27	19,2	11,8	ARX332X350DF1	ARUX332X350DF1

CAP (μ F)	Rated Voltage (Vn)	Case Code	Φ x h (mm)	TG δ 100Hz	ESR	ESR	Z	I ripple	I ripple	CATALOGUE NUMBER	
					max 100Hz (mOhm)	typ 100Hz (mOhm)	max 10Khz (mOhm)	55°C 100Hz (A)	85°C 100Hz (A)	Flat bottom	Mounting stud
220	400	AA	35 x 59	0,07	456	365	411	2,3	1,4	ARX221X400AA1	ARUX221X400AA1
330		AB	35 x 79	0,07	304	243	280	3,5	2,1	ARX331X400AB1	ARUX331X400AB1
470		AC	35 x 105	0,08	244	195	215	4,4	2,7	ARX471X400AC1	ARUX471X400AC1
680		BB	51 x 83	0,08	169	135	156	5,7	3,5	ARX681X400BB1	ARUX681X400BB1
1000		BC	51 x 105	0,08	115	92	73	7,9	4,8	ARX102X400BC1	ARUX102X400BC1
2200		BC	51 x 105	0,09	59	47	44	11,9	7,3	ARX222X400BC1	ARUX222X400BC1
1500		CC	63 x 107	0,09	86	69	57	10,3	6,3	ARX152X400CC1	ARUX152X400CC1
2200		DC	76 x 107	0,10	65	52	44	13,1	8,0	ARX222X400DC1	ARUX222X400DC1
3300		DF	76 x 147	0,10	43	35	30	18,4	11,2	ARX332X400DF1	ARUX332X400DF1

CAP (μ F)	Rated Voltage (Vn)	Case Code	Φ x h (mm)	TG δ 100Hz	ESR	ESR	Z	I ripple	I ripple	CATALOGUE NUMBER	
					max 100Hz (mOhm)	typ 100Hz (mOhm)	max 10Khz (mOhm)	55°C 100Hz (A)	85°C 100Hz (A)	Flat bottom	Mounting stud
150	450	AA	35 x 59	0,08	764	611	702	1,8	1,1	ARX151X450AA1	ARUX151X450AA1
220		AB	35 x 79	0,08	521	417	320	2,6	1,6	ARX221X450AB1	ARUX221X450AB1
330		AC	35 x 105	0,08	347	278	213	3,7	2,3	ARX331X450AC1	ARUX331X450AC1
470		BB	51 x 83	0,10	305	244	190	4,3	2,6	ARX471X450BB1	ARUX471X450BB1
680		BC	51 x 105	0,10	211	169	131	5,8	3,6	ARX681X450BC1	ARUX681X450BC1
1000		CC	63 x 107	0,10	143	115	91	7,9	4,9	ARX102X450CC1	ARUX102X450CC1
1500		CD	63 x 118	0,10	96	76	62	10,2	6,3	ARX152X450CD1	ARUX152X450CD1
1500		DC	76 x 107	0,10	96	76	62	10,8	6,6	ARX152X450DC1	ARUX152X450DC1
2200		DF	76 x 147	0,10	65	52	44	15,0	9,2	ARX222X450DF1	ARUX222X450DF1
3300		DF	76 x 147	0,10	43	35	30	18,4	11,2	ARX332X450DF1	ARUX332X450DF1

AR- / AR- HG SERIES

ALUMINIUM ELECTROLYTIC CAPACITORS GENERAL PURPOSE

Series	Capacitance range	Voltage Range	Temperature range	Case $\Phi \times H$	Applications
AR / ARU	100 - 470000	25 - 450	-40 °C , +85°C	35 x 59	High capacitance, reduced volume, long life, industrial applications
AR-HG ARU-HG				76 x 147	High CV product for applications where dimensions are very important

MECHANICAL OUTLINES:

CASE: aluminium made

TERMINALS: screw

SEALING: hermetic by beading on an EPR gasket, housed on a resin cover

PRESSURE RELEASE VENT: made in silicone-rubber

SLEEVE: self-extinguishing thermoshrinkable sleeve

SIZE: see enclosed drawings

MOUNTING HARDWARE: see hardware section

SPECIFICATIONS	TEMPERATURE RANGE	CAPACITANCE
CECC 30300 IEC 384-4 ("long life grade") MIL C62D DIN 41240 / DIN 45910	Operating: -40 °C/ +85 °C Climatic category : 40/85/56	Tolerance shall be within the following limits: <ul style="list-style-type: none"> • standard tolerance -10% +30% • or available on request -20% +20%

LEAKAGE CURRENT:

After the rated voltage has been applied to the capacitor for 5 minutes the leakage current must be:

Maximum limit	at 25 °C	$I_f \leq 0,004 * C * V$
Operating limit	at 25 °C:	$I_f \leq 0,001 * C * V$

where I_f = leakage current (μA)

C = capacitance (μF)

V = rated voltage (V)

IMPORTANT

- When using high-capacitance and high-voltage electrolytic capacitors it is important to remember that the inner part (the rolled section) is not insulated from can: between the negative pole and the aluminium can there is a variable and not defined resistance essentially due to the electrolyte used in capacitor manufacture.

SURGE VOLTAGE

Working Voltage	25	40	50	63	75	100	160	200	250	350	400	420	450
Surge Voltage	29	46	58	73	86	115	185	230	290	385	440	460	495

RIPPLE CURRENT:

The allowable values of ripple current in amperes, are related to the temperature and frequency by the formula:

$$I_{rip} = K_t \cdot K_f \cdot I_{r85}$$

where I_{r85} is the limit given by tables, referred to a temperature of 85 °C and to a frequency of 100 HZ and K_t or K_f are values here below tabulated:

Note . Ripple current is function of the capacitance tolerance

°C	40	55	65	75	85
K_t	2.1	1.8	1.6	1.3	1.0

V_n	K_f					
	V=50	50<V=300	V>300	V=50	50<V=300	V>300
Hz	Code Diameter A,B			Code Diameter C,D		
50	0.82	0.79	0.76	0.86	0.78	0.72
100	1	1	1	1	1	1
120	1.03	1.04	1.04	1.01	1.02	1.03
300	1.12	1.16	1.28	1.03	1.08	1.24
500	1.15	1.22	1.39	1.03	1.09	1.32
>1000	1.18	1.25	1.45	1.03	1.09	1.37

DIMENSIONS

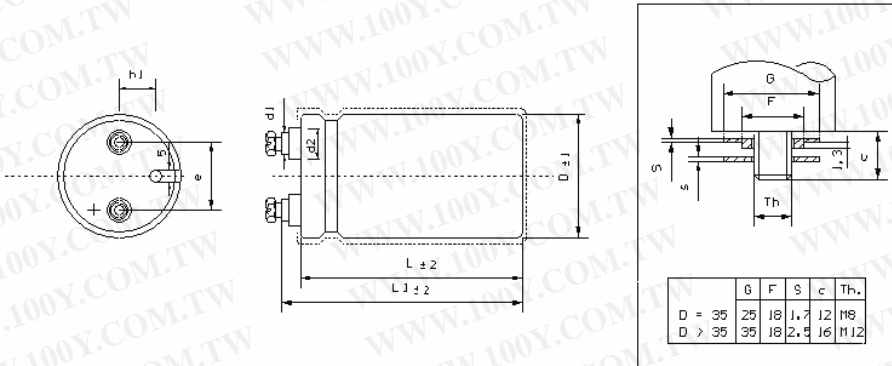

Insert screw thread = m5	Screw torque for hex nuts m8 = 4 Nm.
Insert screw torque max. (m5) = 2 Nm.	Screw torque for hex nuts m12 = 10 Nm
Insert screw length (terminal code "-x") = 10 mm.	

CASE CODE	$\Phi \times L$ (mm)	l_1	d_1 ± 0.5	d_2 ± 0.5	h_1	e	CASE CODE	$\Phi \times L$ (mm)	l_1	d_1 ± 0.5	d_2 ± 0.5	h_1	e
AA	35 x 59	65	8	12	8	12,7	CC	63 x 107	111	13	18	16	28,6
AB	35 X 83	89	8	12	8	12,7							
AC	35 X 105	109	8	12	8	12,7	DC	76 x 107	111	13	18	19	31,8
BB	51 x 83	89	13	18	13	22,2							
BC	51 x 105	109	13	18	13	22,2	DF	76 x 147	151	13	18	19	31,8

STANDARD MOUNTING STUD HARDWARE - INSULATING PLASTIC WASHER AND METALLIC NUT

EXPECTED LIFE VS. TEMPERATURE AND RIPPLE CURRENT

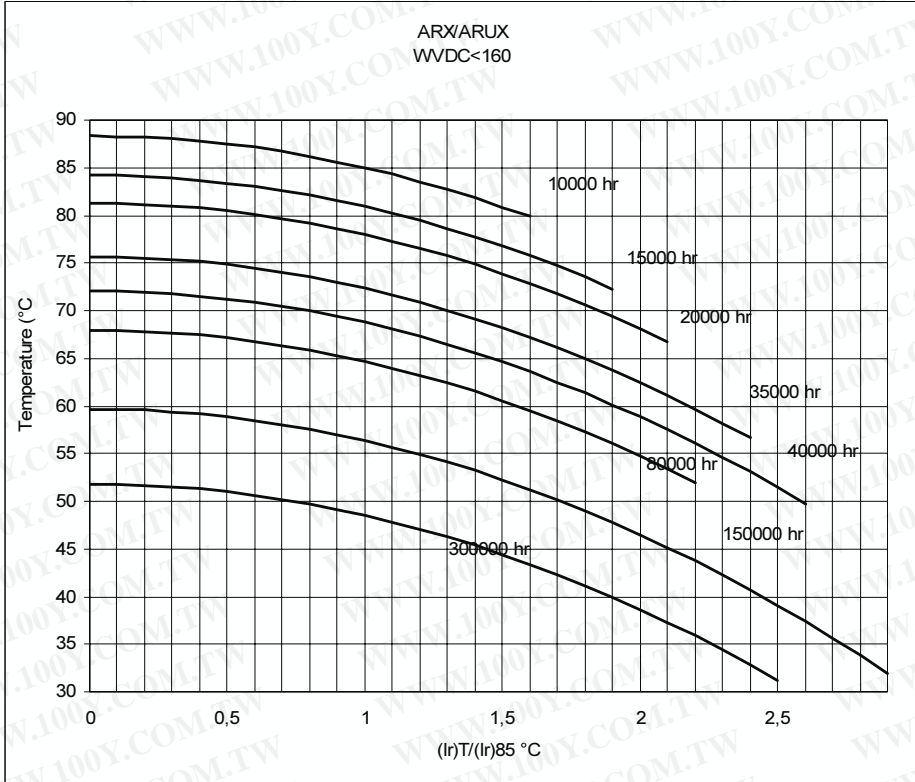

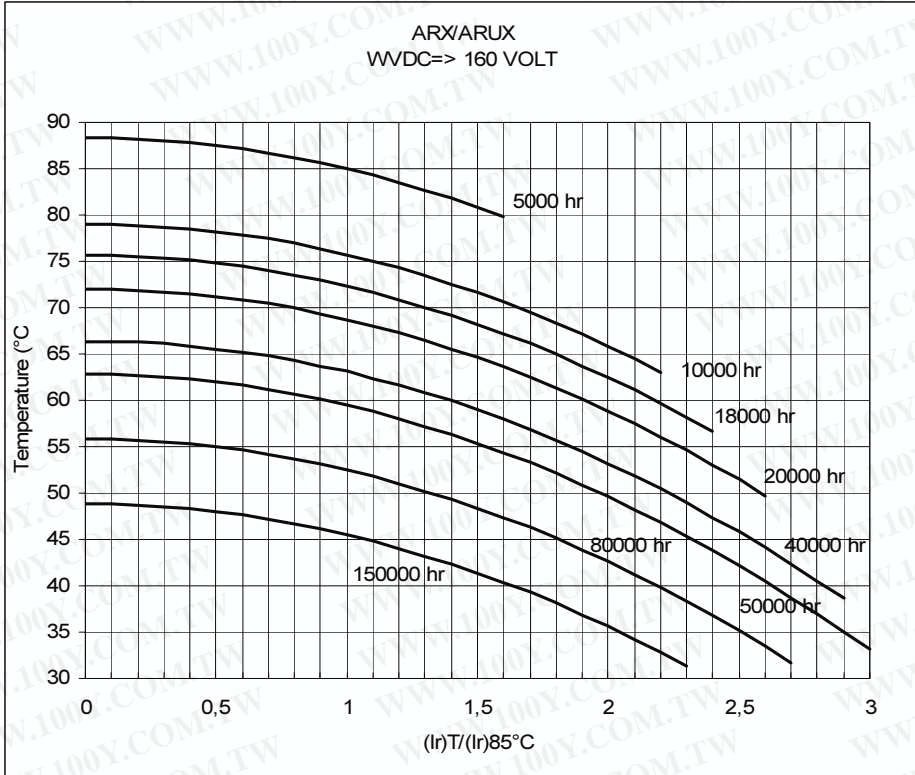

Expected life criteria: see introduction

ARX - HG / ARUX - HG

CAP (μ F)	Rated Voltage (Vn)	Case Code	Φ x h (mm)	TG δ 100Hz	ESR	ESR	Z	I ripple	I ripple	CATALOGUE NUMBER	
					max 100Hz (mOhm)	typ 100Hz (mOhm)	max 10KHz (mOhm)	55°C 100Hz (A)	85°C 100Hz (A)	Flat bottom	Mounting stud
15000	25	AA	35 x 59	0,35	33	27	26	8,6	5,0	ARX-HG153X25AA1	ARUX-HG153X25AA1
22000		AB	35 x 79	0,42	27	22	23	11,6	6,7	ARX-HG223X25AB1	ARUX-HG223X25AB1
33000		AC	35 x 105	0,47	20	16	17	15,2	8,9	ARX-HG333X25AC1	ARUX-HG333X25AC1
47000		BB	51 x 83	0,70	21	17	16	16,2	9,4	ARX-HG473X25BB1	ARUX-HG473X25BB1
68000		BC	51 x 105	0,75	16	13	14	21,3	12,4	ARX-HG683X25BC1	ARUX-HG683X25BC1
100000		CC	51 x 105	0,85	12	10	10	24,2	14,1	ARX-HG104X25CC1	ARUX-HG104X25CC1
150000		CC	63 x 107	0,90	9	7	8	32,5	18,9	ARX-HG154X25CC1	ARUX-HG154X25CC1
220000		DC	76 x 107	1,00	7	5	6	41,5	24,2	ARX-HG224X25DC1	ARUX-HG224X25DC1
330000		DF	76 x 147	1,30	6	5	5	50,9	29,7	ARX-HG334X25DF1	ARUX-HG334X25DF1

CAP (μ F)	Rated Voltage (Vn)	Case Code	Φ x h (mm)	TG δ 100Hz	ESR	ESR	Z	I ripple	I ripple	CATALOGUE NUMBER	
					max 100Hz (mOhm)	typ 100Hz (mOhm)	max 10KHz (mOhm)	55°C 100Hz (A)	85°C 100Hz (A)	Flat bottom	Mounting stud
10000	40	AA	35 x 59	0,27	39	31	30	8,0	4,6	ARX-HG103X40AA1	ARUX-HG103X40AA1
15000		AB	35 x 79	0,35	33	27	25	10,5	6,1	ARX-HG153X40AB1	ARUX-HG153X40AB1
22000		AC	35 x 105	0,42	27	22	18	13,2	7,7	ARX-HG223X40AC1	ARUX-HG223X40AC1
33000		BB	51 x 83	0,45	20	16	18	16,9	9,8	ARX-HG333X40BB1	ARUX-HG333X40BB1
47000		BB	51 x 83	0,48	15	12	18	16,9	11,4	ARX-HG473X40BB1	ARUX-HG473X40BB1
47000		BC	51 x 105	0,51	16	12	14	21,4	13,3	ARX-HG473X40BC1	ARUX-HG473X40BC1
100000		CC	63 x 107	0,70	10	8	9	30,0	17,5	ARX-HG104X40CC1	ARUX-HG104X40CC1
150000		DC	76 x 107	0,90	9	7	8	36,1	21,1	ARX-HG154X40DC1	ARUX-HG154X40DC1
220000		DF	76 x 147	1,30	8	7	7	41,6	24,3	ARX-HG224X40DF1	ARUX-HG224X40DF1

CAP (μ F)	Rated Voltage (Vn)	Case Code	Φ x h (mm)	TG δ 100Hz	ESR	ESR	Z	I ripple	I ripple	CATALOGUE NUMBER	
					max 100Hz (mOhm)	typ 100Hz (mOhm)	max 10KHz (mOhm)	55°C 100Hz (A)	85°C 100Hz (A)	Flat bottom	Mounting stud
4700	63	AA	35 x 59	0,15	46	37	30	7,4	4,1	ARX-HG472X63AA1	ARUX-HG472X63AA1
6800		AB	35 x 79	0,20	42	34	27	9,3	5,2	ARX-HG682X63AB1	ARUX-HG682X63AB1
10000		AB	35 x 79	0,22	32	25	21	10,8	6,0	ARX-HG103X63AB1	ARUX-HG103X63AB1
15000		AC	35 x 105	0,25	24	19	18	14,1	7,8	ARX-HG153X63AC1	ARUX-HG153X63AC1
22000		BB	51 x 83	0,33	21	17	17	16,1	8,9	ARX-HG223X63BB1	ARUX-HG223X63BB1
33000		BB	51 x 105	0,38	17	13	14	20,8	11,6	ARX-HG333X63BC1	ARUX-HG333X63BC1
47000		CC	63 x 107	0,33	10	8	9	30,0	16,7	ARX-HG473X63CC1	ARUX-HG473X63CC1
68000		DC	76 x 107	0,39	8	7	7	36,9	20,5	ARX-HG683X63DC1	ARUX-HG683X63DC1
100000		DF	76 x 147	0,45	6	5	6	47,7	26,5	ARX-HG104X63DF1	ARUX-HG104X63DF1

CAP (μ F)	Rated Voltage (Vn)	Case Code	Φ x h (mm)	TG δ 100Hz	ESR	ESR	Z	I ripple	I ripple	CATALOGUE NUMBER	
					max 100Hz (mOhm)	typ 100Hz (mOhm)	max 10Khz (mOhm)	55°C 100Hz (A)	85°C 100Hz (A)	Flat bottom	Mounting stud
2200	100	AA	35 x 59	0,12	78	63	47	5,6	3,1	ARX-HG222X100AA1	ARUX-HG222X100AA1
3300		AB	35 x 79	0,12	52	42	34	8,4	4,7	ARX-HG332X100AB1	ARUX-HG332X100AB1
4700		AB	35 x 79	0,12	37	29	27	9,7	5,4	ARX-HG472X100AB1	ARUX-HG472X100AB1
6800		AC	35 x 105	0,12	25	20	20	13,2	7,3	ARX-HG682X100AC1	ARUX-HG682X100AC1
10000		BB	51 x 83	0,12	17	14	17	15,6	8,7	ARX-HG103X100BB1	ARUX-HG103X100BB1
15000		CC	51 x 105	0,12	11	9	13	21,6	12	ARX-HG153X100BC1	ARUX-HG153X100BC1
22000		CC	63 x 107	0,12	8	6	9	27,8	15,4	ARX-HG223X100CC1	ARUX-HG223X100CC1
33000		DC	76 x 107	0,12	5	4	8	35,9	20	ARX-HG333X100DC1	ARUX-HG333X100DC1
47000		DF	76 x 147	0,12	4	3	7	46,7	26	ARX-HG473X100DF1	ARUX-HG473X100DF1

CAP (μ F)	Rated Voltage (Vn)	Case Code	Φ x h (mm)	TG δ 100Hz	ESR	ESR	Z	I ripple	I ripple	CATALOGUE NUMBER	
					max 100Hz (mOhm)	typ 100Hz (mOhm)	max 10Khz (mOhm)	55°C 100Hz (A)	85°C 100Hz (A)	Flat bottom	Mounting stud
1000	160	AA	35 x 59	0,12	172	138	94	4,2	2,3	ARX-HG102X160AA1	ARUX-HG102X160AA1
1500		AB	35 x 79	0,12	115	92	62	6,2	3,4	ARX-HG152X160AB1	ARUX-HG152X160AB1
2200		AC	35 x 105	0,12	78	63	41	8,5	4,7	ARX-HG222X160AC1	ARUX-HG222X160AC1
3300		BB	51 x 83	0,12	52	42	29	11,3	6,3	ARX-HG332X160BB1	ARUX-HG332X160BB1
4700		CC	51 x 105	0,12	37	29	25	14,0	7,8	ARX-HG472X160BC1	ARUX-HG472X160BC1
6800		CC	63 x 107	0,12	25	20	20	18,9	10,5	ARX-HG682X160CC1	ARUX-HG682X160CC1
10000		CC	63 x 107	0,12	17	14	18	20,5	11,4	ARX-HG103X160CC1	ARUX-HG103X160CC1
12000		DC	76 x 107	0,12	14	11	15	25,0	13,9	ARX-HG123X160DC1	ARUX-HG123X160DC1
22000		DF	76 x 147	0,12	8	6	8	36,4	20,2	ARX-HG223X160DF1	ARUX-HG223X160DF1

CAP (μ F)	Rated Voltage (Vn)	Case Code	Φ x h (mm)	TG δ 100Hz	ESR	ESR	Z	I ripple	I ripple	CATALOGUE NUMBER	
					max 100Hz (mOhm)	typ 100Hz (mOhm)	max 10Khz (mOhm)	55°C 100Hz (A)	85°C 100Hz (A)	Flat bottom	Mounting stud
680	200	AA	35 x 59	0,12	253	202	111	3,8	2,1	ARX-HG681X200AA1	ARUX-HG681X200AA1
1000		AB	35 x 79	0,12	172	138	78	5,6	3,1	ARX-HG102X200AB1	ARUX-HG102X200AB1
1500		AC	35 x 105	0,12	115	92	51	7,9	4,4	ARX-HG152X200AC1	ARUX-HG152X200AC1
2200		BB	51 x 83	0,12	78	63	36	10,3	5,7	ARX-HG222X200BB1	ARUX-HG222X200BB1
3300		BC	51 x 105	0,12	52	42	30	12,8	7,1	ARX-HG332X200BC1	ARUX-HG332X200BC1
4700		CC	63 x 107	0,12	37	29	21	17,2	9,6	ARX-HG472X200CC1	ARUX-HG472X200CC1
10000		DC	76 x 107	0,12	17	14	14	25,5	14,2	ARX-HG103X200DC1	ARUX-HG103X200DC1
15000		DF	76 x 147	0,12	11	9	12	32,0	17,8	ARX-HG153X200DF1	ARUX-HG153X200DF1

CAP (μ F)	Rated Voltage (Vn)	Case Code	Φ x h (mm)	TG δ 100Hz	ESR max 100Hz (mOhm)	ESR typ 100Hz (mOhm)	Z max 10KHz (mOhm)	I ripple 55°C 100Hz (A)	I ripple 85°C 100Hz (A)	CATALOGUE NUMBER	
										Flat bottom	Mounting stud
470	250	AA	35 x 59	0,12	366	293	155	3,2	1,8	ARX-HG471X250AA1	ARUX-HG471X250AA1
680		AB	35 x 79	0,12	253	202	107	4,7	2,6	ARX-HG681X250AB1	ARUX-HG681X250AB1
1000		AC	35 x 105	0,12	172	138	86	6,1	3,4	ARX-HG102X250AC1	ARUX-HG102X250AC1
1500		BB	51 x 83	0,12	115	92	59	8,0	4,5	ARX-HG152X250BB1	ARUX-HG152X250BB1
2200		BC	51 x 105	0,12	78	63	44	10,5	5,8	ARX-HG222X250BC1	ARUX-HG222X250BC1
3300		CC	51 x 105	0,12	52	42	30	12,8	7,1	ARX-HG332X250CC1	ARUX-HG332X250CC1
4700		BC	63 x 107	0,12	37	29	23	17,2	9,6	ARX-HG472X250CC1	ARUX-HG472X250CC1
6800		DC	76 x 107	0,12	25	20	20	21,1	11,7	ARX-HG682X250DC1	ARUX-HG682X250DC1
10000		DF	76 x 147	0,12	17	14	17	26,1	14,5	ARX-HG103X250DF1	ARUX-HG103X250DF1

CAP (μ F)	Rated Voltage (Vn)	Case Code	Φ x h (mm)	TG δ 100Hz	ESR max 100Hz (mOhm)	ESR typ 100Hz (mOhm)	Z max 10KHz (mOhm)	I ripple 55°C 100Hz (A)	I ripple 85°C 100Hz (A)	CATALOGUE NUMBER	
										Flat bottom	Mounting stud
330	350	AA	35 x 59	0,12	521	417	217	2,7	1,5	ARX-HG331X350AA1	ARUX-HG331X350AA1
470		AB	35 x 79	0,12	366	293	155	3,9	2,2	ARX-HG471X350AB1	ARUX-HG471X350AB1
680		AC	35 x 105	0,12	253	202	107	5,3	2,9	ARX-HG681X350AC1	ARUX-HG681X350AC1
1000		AC	35 x 105	0,12	172	138	78	6,4	3,6	ARX-HG102X350AC1	ARUX-HG102X350AC1
1500		BB	51 x 83	0,12	115	92	51	8,6	4,8	ARX-HG152X350BB1	ARUX-HG152X350BB1
2200		BC	51 x 105	0,12	78	63	35	11,7	6,5	ARX-HG222X350BC1	ARUX-HG222X350BC1
3300		CC	63 x 107	0,12	52	42	25	16,1	9	ARX-HG332X350CC1	ARUX-HG332X350CC1
4700		DC	76 x 107	0,12	37	29	22	19,2	10,7	ARX-HG472X350DC1	ARUX-HG472X350DC1
6800		DF	76 x 147	0,12	25	20	18	26,4	14,6	ARX-HG682X350DF1	ARUX-HG682X350DF1

CAP (μ F)	Rated Voltage (Vn)	Case Code	Φ x h (mm)	TG δ 100Hz	ESR max 100Hz (mOhm)	ESR typ 100Hz (mOhm)	Z max 10KHz (mOhm)	I ripple 55°C 100Hz (A)	I ripple 85°C 100Hz (A)	CATALOGUE NUMBER	
										Flat bottom	Mounting stud
330	400	AA	35 x 59	0,12	521	417	221	2,7	1,5	ARX-HG331X400AA1	ARUX-HG331X400AA1
470		AB	35 x 79	0,12	366	293	155	3,9	2,2	ARX-HG471X400AB1	ARUX-HG471X400AB1
680		AC	35 x 105	0,12	253	202	111	5,3	2,9	ARX-HG681X400AC1	ARUX-HG681X400AC1
1000		BB	51 x 83	0,12	172	138	78	7,0	3,9	ARX-HG102X400BB1	ARUX-HG102X400BB1
1500		BB	51 x 83	0,12	115	92	78	8,0	4,5	ARX-HG152X400BB1	ARUX-HG152X400BB1
1500		BC	51 x 105	0,12	115	92	50	9,7	5,4	ARX-HG152X400BC1	ARUX-HG152X400BC1
2200		CC	63 x 107	0,12	78	63	40	12,4	6,9	ARX-HG222X400CC1	ARUX-HG222X400CC1
3300		DC	76 x 107	0,12	52	42	29	16,5	9,2	ARX-HG332X400DC1	ARUX-HG332X400DC1
4700		DF	76 x 147	0,12	37	29	21	22,5	12,5	ARX-HG472X400DF1	ARUX-HG472X400DF1
330		AA	35 x 59	0,12	521	417	221	2,7	1,5	ARX-HG331X400AA1	ARUX-HG331X400AA1

CAP (μF)	Rated Voltage (Vn)	Case Code	$\Phi \times h$ (mm)	TG δ 100Hz	ESR max	ESR typ	Z max	I ripple 55°C	I ripple 85°C	CATALOGUE NUMBER	
					100Hz (mOhm)	100Hz (mOhm)	10KHz (mOhm)	100Hz (A)	100Hz (A)	Flat bottom	Mounting stud
220	450	AA	35 x 59	0,12	782	625	480	1,8	1,0	ARX-HG221X450AA1	ARUX-HG221X450AA1
330		AB	35 x 79	0,12	521	417	323	2,6	1,5	ARX-HG331X450AB1	ARUX-HG331X450AB1
470		AC	35 x 105	0,12	366	293	237	4,6	2,5	ARX-HG471X450AC1	ARUX-HG471X450AC1
680		BB	51 x 83	0,12	253	202	166	4,7	2,6	ARX-HG681X450BB1	ARUX-HG681X450BB1
1000		BC	51 x 105	0,12	172	138	112	6,4	3,6	ARX-HG102X450BC1	ARUX-HG102X450BC1
1500		CC	63 x 107	0,12	115	92	75	8,9	4,9	ARX-HG152X450CC1	ARUX-HG152X450CC1
2200		DC	76 x 107	0,12	78	63	56	12,0	6,7	ARX-HG222X450DC1	ARUX-HG222X450DC1
4700		DF	76 x 147	0,12	37	29	28	20,0	11,1	ARX-HG472X450DF1	ARUX-HG472X450DF1

AY- / AYU- HR SERIES

ALUMINIUM ELECTROLYTIC CAPACITORS HIGH RIPPLE CURRENT

Series	Capacitance range	Voltage range	Temperature range	Case $\Phi \times H$	Applications
AY-HR AYU-HR	1000-100000	16 - 500	-40 °C , +85°C	51 x 105 90 x 222	High ripple current High reliability Long life

MECHANICAL OUTLINES:

CASE: aluminium made

TERMINALS: screw

SEALING: hermetic by beading on an EPR gasket, housed on a resin cover

PRESSURE RELEASE VENT: made in silicone-rubber

SLEEVE: self-extinguishing thermoshrinkable sleeve

SIZE: see enclosed drawings

MOUNTING HARDWARE: see hardware section

SPECIFICATIONS	TEMPERATURE RANGE	CAPACITANCE
CECC 30300 IEC 384-4 ("long life grade") MIL C62D DIN 41240 / DIN 45910	Operating: -40 °C / +85 °C Climatic Category : 40/85/56	Tolerance shall be within the following limits: <ul style="list-style-type: none"> • standard tolerance -10% +30% • or available on request -20% +20%

LEAKAGE CURRENT:

After the rated voltage has been applied to the capacitor for 5 minutes the leakage current must be:

Maximum limit	at 25 °C	$I_f \leq 0,004 * C * V$
Operating limit	at 25 °C:	$I_f \leq 0,001 * C * V$

where I_f = leakage current (μA)

C = capacitance (μF)

V = rated voltage (V)

IMPORTANT

- When using high-capacitance and high-voltage electrolytic capacitors it is important to remember that the inner part (the rolled section) is not insulated from can; between the negative pole and the aluminium can there is a variable and not defined resistance essentially due to the electrolyte used in capacitor manufacture.

SURGE VOLTAGE

Working Voltage	16	25	40	50	63	75	100	160	200	250	350	400	420	450	500
Surge Voltage	18	29	46	58	73	86	115	185	230	290	385	440	460	495	525

RIPPLE CURRENT:

the allowable values of ripple current in amperes, are related to temperature and frequency by the formula:

$$I_{rip} = K_t * K_f * I_{r85}$$

where I_{r85} is the limit given by tables, referred to a temperature of 85 °C and to a frequency of 100 HZ and K_t or K_f are values here below tabulated:

°C	40	55	65	75	80	85
K_t	1.65	1.5	1.4	1.2	1.1	1.0

V_n Hz	Kf			
	50<V=300		V>300	
	Code Diameter A,B		Code Diameter C,D	
50	0.79	0.76	0.78	0.72
100	1	1	1	1
120	1.04	1.04	1.02	1.03
200	1.12	1.17	1.06	1.14
300	1.16	1.28	1.08	1.24
400	1.20	1.35	1.09	1.29
500	1.22	1.39	1.09	1.32
>1000	1.25	1.45	1.09	1.37

Note : Ripple current is function of the capacitance tolerance.
DIMENSIONS

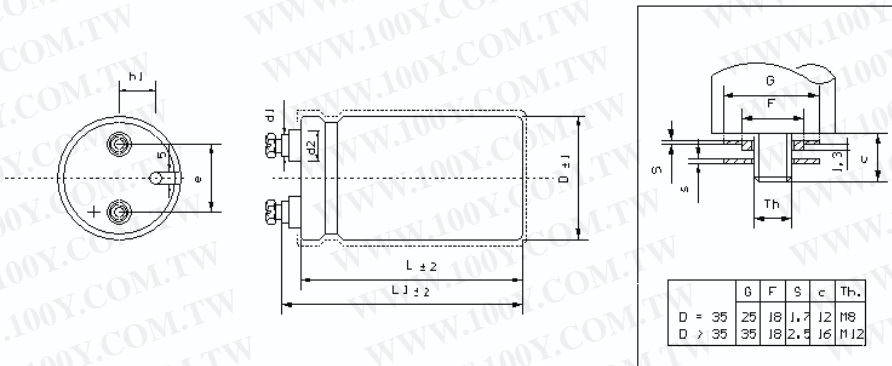

Insert Screw Thread (D= 51, 63, 76) = M5	Insert Screw Thread (D= 90) = M6
Insert Screw Length = 10 mm.	Insert Screw Torque Max (M5) = 2 Nm.
Insert Screw Torque Max. (M6) = 2,5 Nm.	Screw Torque For Hex Nuts M12 = 10 Nm.

CASE CODE	Φ X L (mm)	l1	d1 +,-0.5	d2 +,-0.5	h1	e	CASE CODE	Φ X L (mm)	l1	d1 +,-0.5	d2 +,-0.5	h1	e
BC	51 x 105	109	13	18	13	22.2	EC	90 x 108	112	17	23	19	31.8
CC	63 x 107	111	13	18	16	28.6	EF	90 x 148	153	17	23	19	31.8
DC	76 x 107	111	13	18	19	31.8	EJ	90 x 222	227	17	23	19	31.8
DF	76 x 147	151	13	18	19	31.8							
DK	76 x 168	173	13	18	19	31.8							
DJ	76 x 217	222	13	18	19	31.8							

STANDARD MOUNTING STUD HARDWARE _ INSULATING PLASTIC WASHERS AND METALLIC NUT
_ PLASTIC NUTS ON REQUEST.

EXPECTED LIFE AS A FUNCTION OF TEMPERATURE AND RIPPLE CURRENT

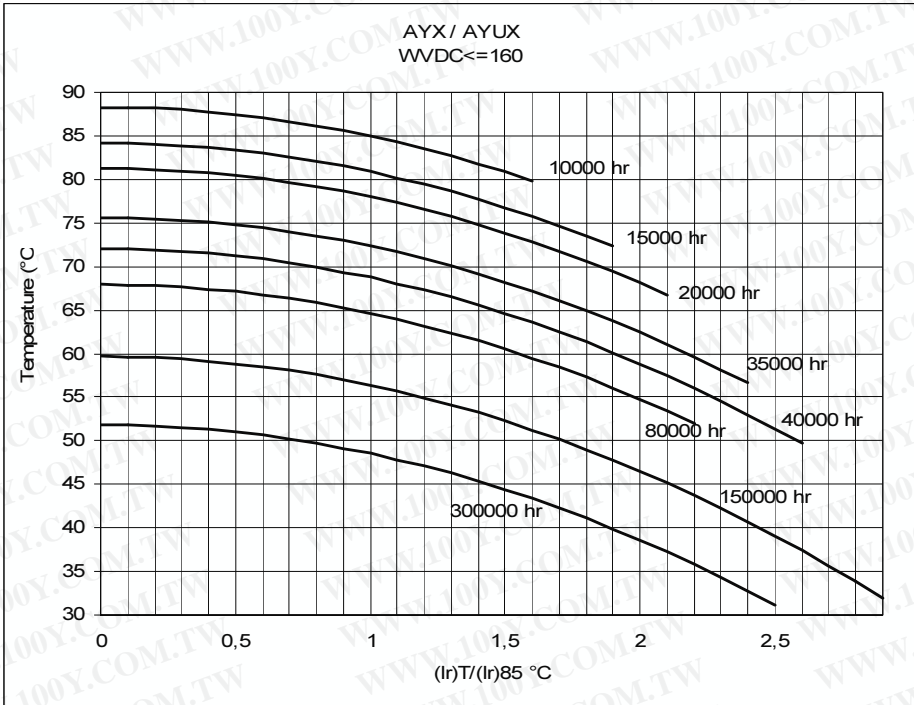

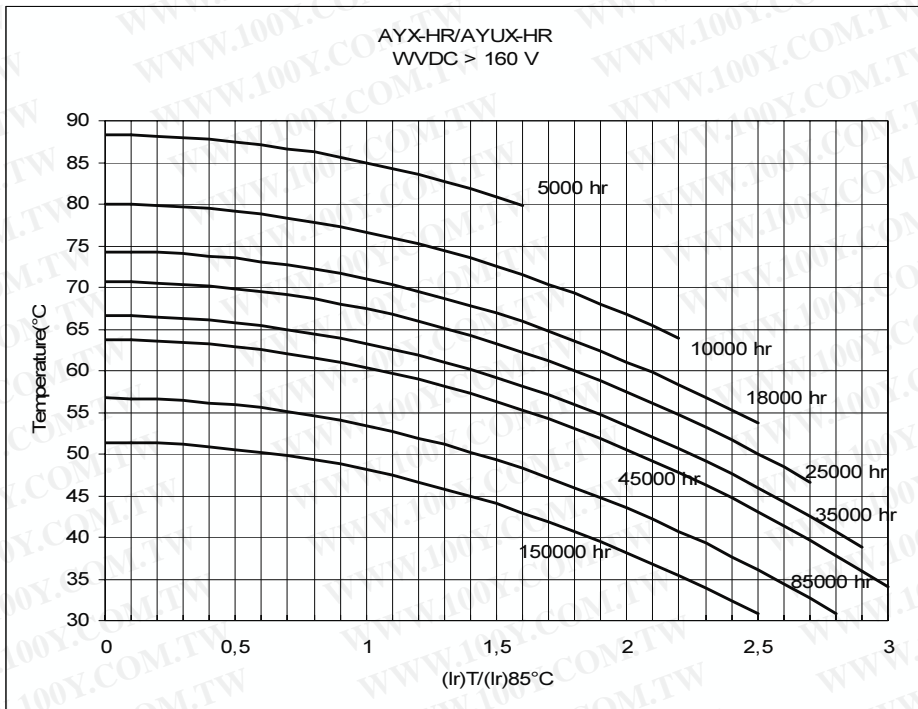

Expected life criteria: see introduction

CAP (μ F)	Rated Voltage (Vn)	Case Code	Φ x h (mm)	TG δ 100Hz	ESR	ESR	Z	I ripple	I ripple	CATALOGUE NUMBER	
					max 100Hz (mOhm)	typ 100Hz (mOhm)	max 10KHz (mOhm)	55°C 100Hz (A)	85°C 100Hz (A)	Flat bottom	Mounting stud
500000	16	DF	76 x 147	2,00	6					AYX-HR504X016DF1	AYUX-HR504X016DF1
1000000		DJ	76 x 217	2,00	3					AYX-HR105X016DJ1	AYUX-HR105X016DJ1

CAP (μ F)	Rated Voltage (Vn)	Case Code	Φ x h (mm)	TG δ 100Hz	ESR	ESR	Z	I ripple	I ripple	CATALOGUE NUMBER	
					max 100Hz (mOhm)	typ 100Hz (mOhm)	max 10KHz (mOhm)	55°C 100Hz (A)	85°C 100Hz (A)	Flat bottom	Mounting stud
68000	25	BC	51 x 105	0,50	12	9	10	24,3	17,3	AYX-HR683X025BC1	AYUX-HR683X025BC1
100000		CC	63 x 107	0,60	10	7	9	30,2	21,6	AYX-HR104X025CC1	AYUX-HR104X025CC1
150000		DC	76 x 106	0,85	9	7	8	34,6	24,7	AYX-HR154X025DC1	AYUX-HR154X025DC1
220000		DF	76 x 147	1,15	8	6	7	41,2	29,4	AYX-HR224X025DF1	AYUX-HR224X025DF1
800000		EJ	90 x 222	1,15	2	2	7	51,5	29,4	AYX-HR804X025EJ1	AYUX-HR804X025EJ1

CAP (μ F)	Rated Voltage (Vn)	Case Code	Φ x h (mm)	TG δ 100Hz	ESR	ESR	Z	I ripple	I ripple	CATALOGUE NUMBER	
					Max 100Hz (mohm)	typ 100Hz (mOhm)	max 10KHz (mOhm)	55°C 100Hz (A)	85°C 100Hz (A)	Flat bottom	Mounting stud
47000	40	BC	51 x 105	0,32	11	8	8	25,2	18	AYX-HR473X040BC1	AYUX-HR473X040BC1
68000		CC	63 x 107	0,38	9	7	7	31,3	22,4	AYX-HR683X040CC1	AYUX-HR683X040CC1
100000		DC	76 x 106	0,46	7	5	6	38,4	27,4	AYX-HR104X040DC1	AYUX-HR104X040DC1
150000		DF	76 x 147	0,65	7	5	6	45,2	32,3	AYX-HR154X040DF1	AYUX-HR154X040DF1

CAP (μ F)	Rated Voltage (Vn)	Case Code	Φ x h (mm)	TG δ 100Hz	ESR	ESR	Z	I ripple	I ripple	CATALOGUE NUMBER	
					Max 100Hz (mOhm)	typ 100Hz (mOhm)	max 10KHz (mOhm)	55°C 100Hz (A)	85°C 100Hz (A)	Flat bottom	Mounting stud
22000	63	BC	51 x 105	0,24	17	13	12	19,9	14,2	AYX-HR223X063BC1	AYUX-HR223X063BC1
33000		CC	51 x 105	0,28	14	10	11	22,6	16,1	AYX-HR333X063BC1	AYUX-HR333X063BC1
47000		CC	63 x 107	0,30	10	8	8	29,3	20,9	AYX-HR473X063CC1	AYUX-HR473X063CC1
68000		DC	76 x 106	0,36	8	6	7	34,5	25,6	AYX-HR683X063DC1	AYUX-HR683X063DC1
100000		DF	76 x 147	0,40	6	5	5	47,1	33,6	AYX-HR104X063DF1	AYUX-HR104X063DF1

CAP (μ F)	Rated Voltage (Vn)	Case Code	Φ x h (mm)	TG δ 100Hz	ESR	ESR	Z	I ripple	I ripple	CATALOGUE NUMBER	
					Max 100Hz (mOhm)	typ 100Hz (mOhm)	max 10Khz (mOhm)	55°C 100Hz (A)	85°C 100Hz (A)	Flat bottom	Mounting stud
10000		BB	51 x 83	0,12	19	14	17	15,6	9	AYX-HR103X100BB1	AYUX-HR103X100BB1
10000	100	BC	51 x 105	0,10	16	12	9	20,8	14,9	AYX-HR103X100BC1	AYUX-HR103X100BC1
15000		BC	51 x 105	0,11	12	9	8	24	17,3	AYX-HR153X100BC1	AYUX-HR153X100BC1
22000		CC	63 x 107	0,15	11	8	7	29,3	20,2	AYX-HR223X100CC1	AYUX-HR223X100CC1
33000		DC	76 x 106	0,18	9	7	7	35,3	25,2	AYX-HR333X100DC1	AYUX-HR333X100DC1
33000		DF	76 x 147	0,16	8	6	7	42,8	30,5	AYX-HR333X100DF1	AYUX-HR333X100DF1
47000		DF	76 x 147	0,18	6	5	5	48,1	34,4	AYX-HR473X100DF1	AYUX-HR473X100DF1

CAP (μ F)	Rated Voltage (Vn)	Case Code	Φ x h (mm)	TG δ 100Hz	ESR	ESR	Z	I ripple	I ripple	CATALOGUE NUMBER	
					Max 100Hz (mOhm)	typ 100Hz (mOhm)	max 10Khz (mOhm)	55°C 100Hz (A)	85°C 100Hz (A)	Flat bottom	Mounting stud
4700	160	BC	51 x 105	0,10	34	25	21	14,3	10,2	AYX-HR472X160BC1	AYUX-HR472X160BC1
4700		CC	63 x 107	0,09	30	23	20	16,9	12,1	AYX-HR472X160CC1	AYUX-HR472X160CC1
6800		DC	76 x 106	0,10	23	18	16	21,5	15,3	AYX-HR682X160DC1	AYUX-HR682X160DC1
10000		DF	76 x 106	0,11	18	13	13	24,8	17,7	AYX-HR103X160DC1	AYUX-HR103X160DC1
15000		DF	76 x 147	0,12	13	10	11	33,3	23,8	AYX-HR153X160DF1	AYUX-HR153X160DF1
22000		DJ	76 x 217	0,14	10	8	8	45,1	32,2	AYX-HR223X160DJ1	AYUX-HR223X160DJ1
15000		EC	90 x 108	0,15	16	12	11	29,3	20,9	AYX-HR153X160EC1	AYUX-HR153X160EC1
22000		EF	90 x 149	0,15	11	8	8	40,3	28,8	AYX-HR223X160EF1	AYUX-HR223X160EF1

CAP (μ F)	Rated Voltage (Vn)	Case Code	Φ x h (mm)	TG δ 100Hz	ESR	ESR	Z	I ripple	I ripple	CATALOGUE NUMBER	
					Max 100Hz (mOhm)	typ 100Hz (mOhm)	max 10Khz (mOhm)	55°C 100Hz (A)	85°C 100Hz (A)	Flat bottom	Mounting stud
3300	200 (**)	BC	51 x 105	0,10	48	36	30	12,5	8,9	AYX-HR332X200BC1	AYUX-HR332X200BC1
4700		CC	63 x 107	0,10	34	25	21	16,8	12	AYX-HR472X200CC1	AYUX-HR472X200CC1
4700		DC	76 x 106	0,09	30	23	21	19,7	14,1	AYX-HR472X200DC1	AYUX-HR472X200DC1
6800		DC	76 x 106	0,10	23	18	16	22,5	16,1	AYX-HR682X200DC1	AYUX-HR682X200DC1
10000		DF	76 x 147	0,11	18	13	13	29,7	21,2	AYX-HR103X200DF1	AYUX-HR103X200DF1
15000		DF	76 x 147	0,12	13	10	10	34,9	24,9	AYX-HR153X200DF1	AYUX-HR153X200DF1
22000		DF	76 x 147	0,13	9	7	7	40,6	29	AYX-HR223M200DF1	AYUX-HR223M200DF1
22000		DK	76 x 168	0,12	9	7	7	45,1	32,2	AYX-HR223X200DK1	AYUX-HR223X200DK1
33000		DK	76 x 168	0,12	6	4	7	55,3	39,5	AYX-HR333X200DK1	AYUX-HR333X200DK1
15000		EC	90 x 108	0,14	15	11	12	31,8	22,7	AYX-HR153X200EC1	AYUX-HR153X200EC1
22000		EC	90 x 108	0,14	10	8	8	43,7	31,2	AYX-HR223X200EC1	AYUX-HR223X200EC1

(**)= \pm 20%

CAP (μ F)	Rated Voltage (Vn)	Case Code	Φ x h (mm)	TG δ 100Hz	ESR	ESR	Z	I ripple	I ripple	CATALOGUE NUMBER	
					Max 100Hz (mOhm)	typ 100Hz (mOhm)	max 10KHz (mOhm)	55°C 100Hz (A)	85°C 100Hz (A)	Flat bottom	Mounting stud
2200	250	BC	51 x 105	0,09	65	49	38	10,8	7,7	AYX-HR222X250BC1	AYUX-HR222X250BC1
3300		CC	63 x 107	0,10	48	36	29	14,1	10,1	AYX-HR332X250CC1	AYUX-HR332X250CC1
4700		DC	76 x 106	0,10	34	25	22	18,7	13,4	AYX-HR472X250DC1	AYUX-HR472X250DC1
6800		DC	76 x 106	0,10	23	18	16	22,5	16,1	AYX-HR682X250DC1	AYUX-HR682X250DC1
10000		DF	76 x 147	0,10	16	12	12	31,2	22,3	AYX-HR103X250DF1	AYUX-HR103X250DF1
15000		DJ	76 x 217	0,12	13	10	10	42,1	30,1	AYX-HR153X250DJ1	AYUX-HR153X250DJ1
22000		DJ	76 x 217	0,12	9	7	10	42,1	30,1	AYX-HR223M250DJ1	AYUX-HR223M250DJ1
10000		EC	90 x 108	0,13	21	16	14	26,9	19,2	AYX-HR103X250EC1	AYUX-HR103X250EC1
15000		EF	90 x 149	0,13	14	10	10	37,4	26,7	AYX-HR153X250EF1	AYUX-HR153X250EF1

(**)=+/-20%

CAP (μ F)	Rated Voltage (Vn)	Case Code	Φ x h (mm)	TG δ 100Hz	ESR	ESR	Z	I ripple	I ripple	CATALOGUE NUMBER	
					Max 100Hz (mOhm)	typ 100Hz (mOhm)	max 10KHz (mOhm)	55°C 100Hz (A)	85°C 100Hz (A)	Flat bottom	Mounting stud
1500	350	BC	51 x 105	0,08	85	64	51	9,4	6,7	AYX-HR152X350BC1	AYUX-HR152X350BC1
2200		CC	63 x 107	0,08	58	43	35	12,9	9,2	AYX-HR222X350CC1	AYUX-HR222X350CC1
3300		DC	76 x 106	0,08	39	29	24	17,5	12,5	AYX-HR332X350DC1	AYUX-HR332X350DC1
4700		DC	76 x 106	0,10	34	25	24	18,7	13,4	AYX-HR472X350DC1	AYUX-HR472X350DC1
4700		DF	76 x 147	0,08	27	20	17	23,9	17,1	AYX-HR472X350DF1	AYUX-HR472X350DF1
6800		DF	76 x 147	0,08	19	14	13	28,8	20,5	AYX-HR682X350DF1	AYUX-HR682X350DF1
6800		DJ	76 x 217	0,08	19	14	11	34,7	24,8	AYX-HR682X350DJ1	AYUX-HR682X350DJ1
10000		DF	76 x 147	0,11	17	13	10	30	21,4	AYX-HR103X350DF1	AYUX-HR103X350DF1
15000		DF	76 x 147	0,12	13	10	10	34,9	24,9	AYX-HR153M350DF1	AYUX-HR153M350DF1
18000		DF	76 x 147	0,12	11	8	9	38,2	37,3	AYX-HR183M350DF1	AYUX-HR183M350DF1
10000	(**)	DJ	76 x 217	0,10	16	12	10	37,7	26,9	AYX-HR103X350DJ1	AYUX-HR103X350DJ1
15000		DJ	76 x 217	0,10	11	8	10	46,1	32,9	AYX-HR153X350DJ1	AYUX-HR153X350DJ1
18000		DF	76 x 147	0,10	9	7	10	46,1	32,8	AYX-HR183M350DF1	AYUX-HR183M350DF1
6800		EC	90 x 108	0,11	26	19	17	24,1	17,2	AYX-HR682X350EC1	AYUX-HR682X350EC1
10000		EF	90 x 149	0,11	18	13	12	33,2	23,7	AYX-HR103X350EF1	AYUX-HR103X350EF1
18000		EF	90 x 149	0,12	11	8	8	46,7	33,6	AYX-HR183M350EF1	AYUX-HR183M350EF1
15000		EJ	90 x 222	0,11	12	9	7	48,2	34,4	AYX-HR153X350EJ1	AYUX-HR153X350EJ1
27000		EJ	90 x 222	0,11	6	5	5	58,4	41,7	AYX-HR273M350EJ1	AYUX-HR273M350EJ1

(**)=+/-20%

CAP (μ F)	Rated Voltage (Vn)	Case Code	Φ x h (mm)	TG δ 100Hz	ESR	ESR	Z	I ripple	I ripple	CATALOGUE NUMBER		
					Max 100Hz (mOhm)	typ 100Hz (mOhm)	max 10KHz (mOhm)	55°C 100Hz (A)	85°C 100Hz (A)	Flat bottom	Mounting stud	
1000	400	BC	51 x 105	0,08	127	96	78	7,7	5,5	AYX-HR102X400BC1	AYUX-HR102X400BC1	
1500		BC	51 x 105	0,08	85	64	50	9,4	6,7	AYX-HR152X400BC1	AYUX-HR152X400BC1	
2200		(**)	BC	51 x 105	0,09	65	49	46	10,2	7,3	AYX-HR222M400BC1	AYUX-HR222M400BC1
2200		(**)	CC	63 x 107	0,09	65	49	43	12,1	8,7	AYX-HR222X400CC1	AYUX-HR222X400CC1
2200			DC	76 x 106	0,08	58	43	34	14,3	10,2	AYX-HR222X400DC1	AYUX-HR222X400DC1
3300		CC	63 x 107	0,09	43	33	29	14,1	10,1	AYX-HR332M400CC1	AYUX-HR332M400CC1	
3300		DC	76 x 106	0,09	43	33	27	16,5	11,8	AYX-HR332X400DC1	AYUX-HR332X400DC1	
3300		DF	76 x 147	0,09	43	33	27	18,9	13,5	AYX-HR332X400DF1	AYUX-HR332X400DF1	
4700		(**)	DC	76 x 106	0,10	34	25	21	17,7	12,7	AYX-HR472M400DC1	AYUX-HR472M400DC1
4700		DF	76 x 147	0,09	30	23	18	22,5	16,1	AYX-HR472X400DF1	AYUX-HR472X400DF1	
6800		(**)	DF	76 x 147	0,07	16	12	16	24,4	17,4	AYX-HR682M400DF1	AYUX-HR682M400DF1
8200		(**)	DF	76 x 147	0,08	16	12	16	26,3	18,8	AYX-HR822M400DF1	AYUX-HR822M400DF1
6800		(**)	DJ	76 x 217	0,08	19	14	12	32,7	23,4	AYX-HR682X400DJ1	AYUX-HR682X400DJ1
10000			DJ	76 x 217	0,11	18	13	11	35,9	25,6	AYX-HR103X400DJ1	AYUX-HR103X400DJ1
4700		EN	90 x 65	0,11	37	28	25	20,1	14,3	AYX-HR472X400EN1	AYUX-HR472X400EN1	
4700		EC	90 x 108	0,11	37	28	23	30,1	21,5	AYX-HR472X400EC1	AYUX-HR472X400EC1	
8200		EF	90 x 149	0,11	21	16	14	33,2	23,7	AYX-HR822X400EF1	AYUX-HR822X400EF1	
10000		EF	90 x 149	0,11	18	13	14	46,1	33	AYX-HR103X400EF1	AYUX-HR103X400EF1	
15000		EJ	90 x 222	0,08	8	6	12	49,8	36	AYX-HR153X400EJ1	AYUX-HR153X400EJ1	

(**)= \pm -20%

CAP (μ F)	Rated Voltage (Vn)	Case Code	Φ x h (mm)	TG δ 100Hz	ESR	ESR	Z	I ripple	I ripple	CATALOGUE NUMBER		
					Max 100Hz (mOhm)	typ 100Hz (mOhm)	max 10KHz (mOhm)	55°C 100Hz (A)	85°C 100Hz (A)	Flat bottom	Mounting stud	
1000	420	BC	51 x 105	0,08	127	96	78	7,7	5,5	AYX-HR102X420BC1	AYUX-HR102X420BC1	
1500		BC	51 x 105	0,08	85	64	50	9,4	6,7	AYX-HR152X420BC1	AYUX-HR152X420BC1	
1500		CC	63 x 107	0,08	85	64	50	10,6	7,6	AYX-HR152X420CC1	AYUX-HR152X420CC1	
2200		CC	63 x 107	0,10	72	54	43	11,5	8,2	AYX-HR222X420CC1	AYUX-HR222X420CC1	
2200		DC	76 x 106	0,08	58	43	34	14,3	10,2	AYX-HR222X420DC1	AYUX-HR222X420DC1	
3300		DC	76 x 106	0,09	43	33	28	16,5	11,8	AYX-HR332X420DC1	AYUX-HR332X420DC1	
3300		DF	76 x 147	0,09	43	33	27	18,9	13,5	AYX-HR332X420DF1	AYUX-HR332X420DF1	
4700		DF	76 x 147	0,09	30	23	18	22,5	16,1	AYX-HR472X420DF1	AYUX-HR472X420DF1	
6800		(**)	DF	76 x 147	0,07	16	12	12	24,4	17,5	AYX-HR682M420DF1	AYUX-HR682M420DF1
6800		(**)	DJ	76 x 217	0,09	21	16	12	32,7	23,4	AYX-HR682X420DJ1	AYUX-HR682X420DJ1
10000			DJ	76 x 217	0,09	14	11	11	39,4	28,1	AYX-HR103X420DJ1	AYUX-HR103X420DJ1
6800		EF	90 x 149	0,11	26	19	11	27,4	19,6	AYX-HR682X420EF1	AYUX-HR682X420EF1	
15000		(**)	EJ	90 x 222	0,11	12	9	11	46,5	35,1	AYX-HR153M420EJ1	AYUX-HR153M420EJ1

(**)= \pm -20%

CAP (μ F)	Rated Voltage (Vn)	Case Code	Φ x h (mm)	TG δ 100Hz	ESR	ESR	Z	I ripple	I ripple	CATALOGUE NUMBER		
					Max 100Hz (mOhm)	typ 100Hz (mOhm)	max 10KHz (mOhm)	55°C 100Hz (A)	85°C 100Hz (A)	Flat bottom	Mounting stud	
1000	450	BC	51 x 105	0,10	159	119	88	6,9	4,9	AYX-HR102X450BC1	AYUX-HR102X450BC1	
1500		(**)	BC	51 x 105	0,10	106	80	88	8	5,7	AYX-HR152M450BC1	AYUX-HR152M450BC1
1500		CC	63 x 107	0,10	106	80	60	9,5	6,8	AYX-HR152X450CC1	AYUX-HR152X450CC1	
2200		CC	63 x 107	0,12	87	65	49	10,5	7,5	AYX-HR222X450CC1	AYUX-HR222X450CC1	
2200		DC	76 x 106	0,10	72	54	43	12,8	9,1	AYX-HR222X450DC1	AYUX-HR222X450DC1	
3300		DC	76 x 106	0,12	58	43	36	14,3	10,2	AYX-HR332X450DC1	AYUX-HR332X450DC1	
3300		DF	76 x 147	0,10	48	36	28	17,9	12,8	AYX-HR332X450DF1	AYUX-HR332X450DF1	
4700		DF	76 x 147	0,12	41	30	24	19,5	13,9	AYX-HR472X450DF1	AYUX-HR472X450DF1	
6800		(**)	DF	76 X 143	0,12	28	21	20	20,2	14,4	AYX-HR682M450DF1	AYUX-HR682M450DF1
6800		DJ	76 X 143	0,12	28	21	17	28,3	20,2	AYX-HR682X450DJ1	AYUX-HR682X450DJ1	
10000		DJ	76 x 217	0,12	19	14	20	32,5	22,8	AYX-HR103X450DJ1	AYUX-HR103X450DJ1	
4700		EC	90 x 108	0,12	41	30	25	21,8	15,6	AYX-HR472X450EC1	AYUX-HR472X450EC1	
6800		EF	90 x 149	0,12	28	21	17	26,2	18,7	AYX-HR682X450EF1	AYUX-HR682X450EF1	
10000		EJ	90 x 222	0,12	19	14	12	37,7	26,9	AYX-HR103X450EJ1	AYUX-HR103X450EJ1	
12000		(**)	EJ	90 x 222	0,12	16	12	12	40,5	26,9	AYX-HR123M450EJ1	AYUX-HR123M450EJ1

CAP (μ F)	Rated Voltage (Vn)	Case Code	Φ x h (mm)	TG δ 100Hz	ESR	ESR	Z	I ripple	I ripple	CATALOGUE NUMBER	
					max 100Hz (mOhm)	typ 100Hz (mOhm)	max 10KHz (mOhm)	55°C 100Hz (A)	85°C 100Hz (A)	Flat bottom	Mounting stud
1000	500	BC	51 x 105	0,13	207	155	124	6	4,3	AYX-HR102X500BC1	AYUX-HR102X500BC1
1500		CC	63 x 107	0,15	159	119	95	7,8	5,5	AYX-HR152X500CC1	AYUX-HR152X500CC1
2200		DC	76 x 106	0,18	130	98	78	9,5	6,8	AYX-HR222X500DC1	AYUX-HR222X500DC1
2200		DF	76 x 147	0,15	109	81	65	11,9	8,5	AYX-HR222X500DF1	AYUX-HR222X500DF1
3300		DF	76 x 147	0,11	53	40	52	13,4	9,5	AYX-HR332X500DF1	AYUX-HR332X500DF1

AY- / AYU- HR SERIES

ALUMINIUM ELECTROLYTIC CAPACITORS HIGH RIPPLE CURRENT

Series	Capacitance range	Voltage range	Temperature range	Case $\Phi \times H$	Applications
AY-HR AYU-HR	1000-100000	16 - 500	-40 °C , +85°C	51 x 105 90 x 222	High ripple current High reliability Long life

MECHANICAL OUTLINES:

CASE: aluminium made

TERMINALS: screw

SEALING: hermetic by beading on an EPR gasket, housed on a resin cover

PRESSURE RELEASE VENT: made in silicone-rubber

SLEEVE: self-extinguishing thermoshrinkable sleeve

SIZE: see enclosed drawings

MOUNTING HARDWARE: see hardware section

SPECIFICATIONS	TEMPERATURE RANGE	CAPACITANCE
CECC 30300 IEC 384-4 ("long life grade") MIL C62D DIN 41240 / DIN 45910	Operating: -40 °C / +85 °C Climatic Category : 40/85/56	Tolerance shall be within the following limits: <ul style="list-style-type: none"> • standard tolerance -10% +30% • or available on request -20% +20%

LEAKAGE CURRENT:

After the rated voltage has been applied to the capacitor for 5 minutes the leakage current must be:

Maximum limit	at 25 °C	$I_f \leq 0,004 * C * V$
Operating limit	at 25 °C:	$I_f \leq 0,001 * C * V$

where I_f = leakage current (μA)

C = capacitance (μF)

V = rated voltage (V)

IMPORTANT

- When using high-capacitance and high-voltage electrolytic capacitors it is important to remember that the inner part (the rolled section) is not insulated from can; between the negative pole and the aluminium can there is a variable and not defined resistance essentially due to the electrolyte used in capacitor manufacture.

SURGE VOLTAGE

Working Voltage	16	25	40	50	63	75	100	160	200	250	350	400	420	450	500
Surge Voltage	18	29	46	58	73	86	115	185	230	290	385	440	460	495	525

RIPPLE CURRENT:

the allowable values of ripple current in amperes, are related to temperature and frequency by the formula:

$$I_{rip} = K_t * K_f * I_{r85}$$

where I_{r85} is the limit given by tables, referred to a temperature of 85 °C and to a frequency of 100 HZ and K_t or K_f are values here below tabulated:

°C	40	55	65	75	80	85
K_t	1.65	1.5	1.4	1.2	1.1	1.0

V_n Hz	Kf			
	50<V=300		V>300	
	Code Diameter A,B		Code Diameter C,D	
50	0.79	0.76	0.78	0.72
100	1	1	1	1
120	1.04	1.04	1.02	1.03
200	1.12	1.17	1.06	1.14
300	1.16	1.28	1.08	1.24
400	1.20	1.35	1.09	1.29
500	1.22	1.39	1.09	1.32
>1000	1.25	1.45	1.09	1.37

Note : Ripple current is function of the capacitance tolerance.
DIMENSIONS

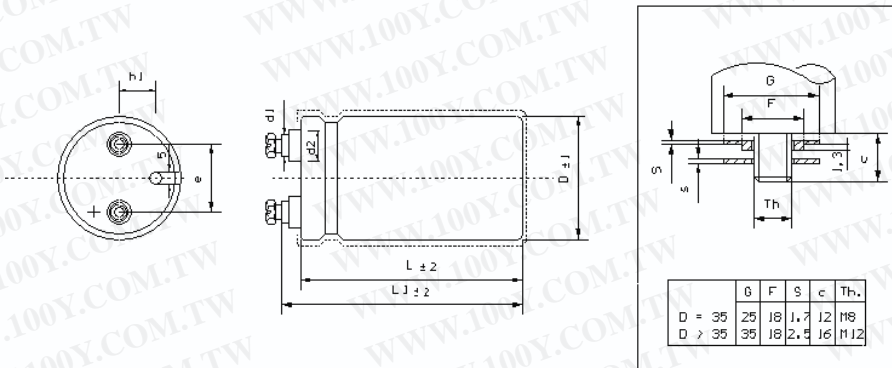

Insert Screw Thread (D= 51, 63, 76) = M5	Insert Screw Thread (D= 90) = M6
Insert Screw Length = 10 mm.	Insert Screw Torque Max (M5) = 2 Nm.
Insert Screw Torque Max. (M6) = 2,5 Nm.	Screw Torque For Hex Nuts M12 = 10 Nm.

CASE CODE	Φ X L (mm)	l1	d1 +,-0.5	d2 +,-0.5	h1	e	CASE CODE	Φ X L (mm)	l1	d1 +,-0.5	d2 +,-0.5	h1	e
BC	51 x 105	109	13	18	13	22.2	EC	90 x 108	112	17	23	19	31.8
CC	63 x 107	111	13	18	16	28.6	EF	90 x 148	153	17	23	19	31.8
DC	76 x 107	111	13	18	19	31.8	EJ	90 x 222	227	17	23	19	31.8
DF	76 x 147	151	13	18	19	31.8							
DK	76 x 168	173	13	18	19	31.8							
DJ	76 x 217	222	13	18	19	31.8							

STANDARD MOUNTING STUD HARDWARE _ INSULATING PLASTIC WASHERS AND METALLIC NUT
_ PLASTIC NUTS ON REQUEST.

EXPECTED LIFE AS A FUNCTION OF TEMPERATURE AND RIPPLE CURRENT

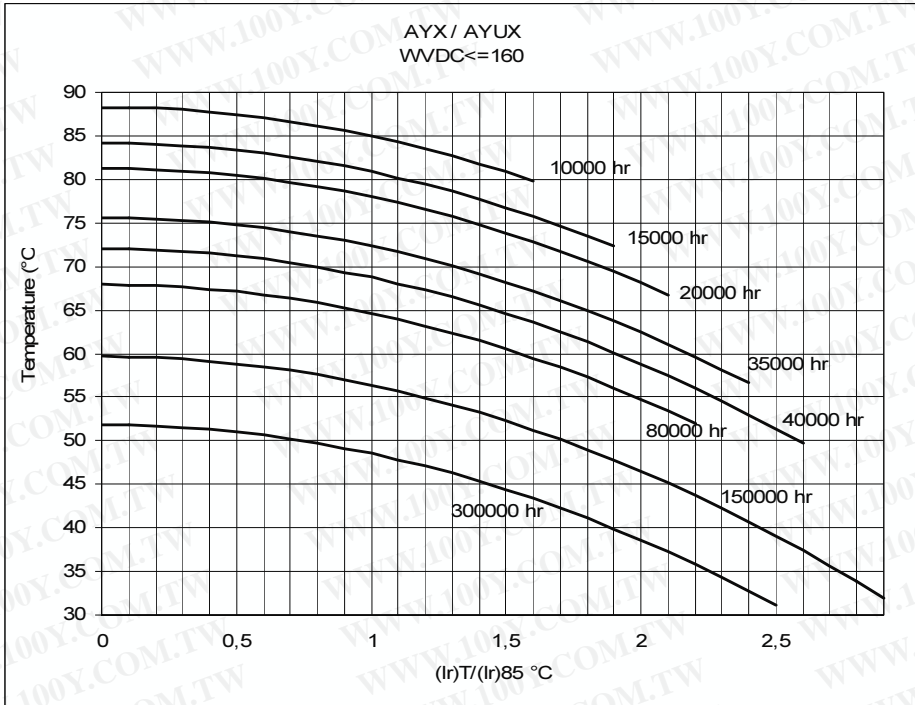

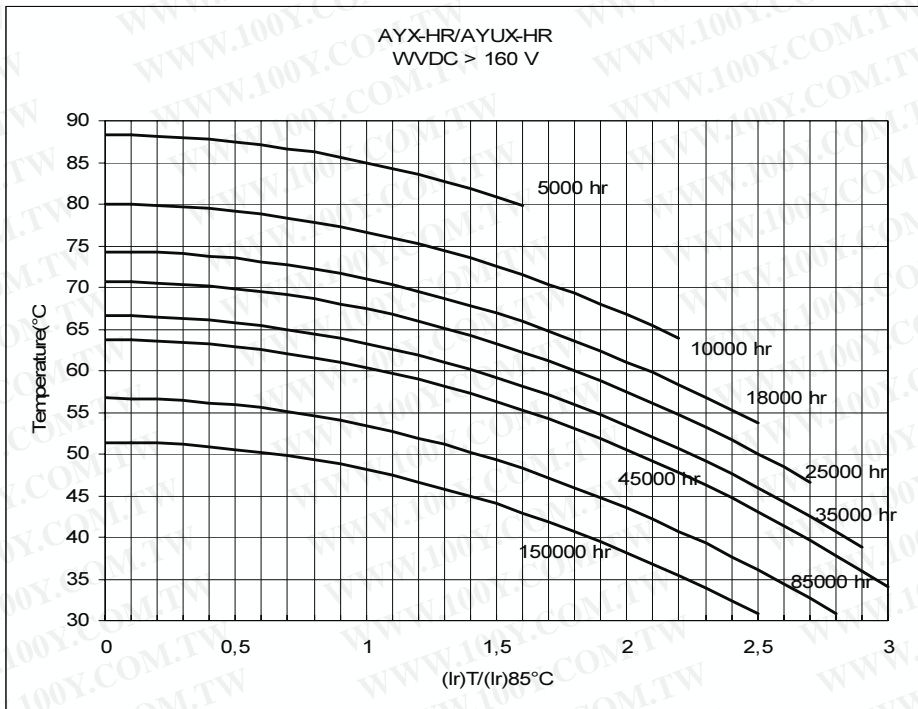

Expected life criteria: see introduction

CAP (μ F)	Rated Voltage (Vn)	Case Code	Φ x h (mm)	TG δ 100Hz	ESR	ESR	Z	I ripple	I ripple	CATALOGUE NUMBER		
					max 100Hz (mOhm)	typ 100Hz (mOhm)	max 10KHz (mOhm)	55°C 100Hz (A)	85°C 100Hz (A)	Flat bottom	Mounting stud	
500000	16	DF	76 x 147	2,00	6						AYX-HR504X016DF1	AYUX-HR504X016DF1
1000000		DJ	76 x 217	2,00	3						AYX-HR105X016DJ1	AYUX-HR105X016DJ1

CAP (μ F)	Rated Voltage (Vn)	Case Code	Φ x h (mm)	TG δ 100Hz	ESR	ESR	Z	I ripple	I ripple	CATALOGUE NUMBER	
					max 100Hz (mOhm)	typ 100Hz (mOhm)	max 10KHz (mOhm)	55°C 100Hz (A)	85°C 100Hz (A)	Flat bottom	Mounting stud
68000	25	BC	51 x 105	0,50	12	9	10	24,3	17,3	AYX-HR683X025BC1	AYUX-HR683X025BC1
100000		CC	63 x 107	0,60	10	7	9	30,2	21,6	AYX-HR104X025CC1	AYUX-HR104X025CC1
150000		DC	76 x 106	0,85	9	7	8	34,6	24,7	AYX-HR154X025DC1	AYUX-HR154X025DC1
220000		DF	76 x 147	1,15	8	6	7	41,2	29,4	AYX-HR224X025DF1	AYUX-HR224X025DF1
800000		EJ	90 x 222	1,15	2	2	7	51,5	29,4	AYX-HR804X025EJ1	AYUX-HR804X025EJ1

CAP (μ F)	Rated Voltage (Vn)	Case Code	Φ x h (mm)	TG δ 100Hz	ESR	ESR	Z	I ripple	I ripple	CATALOGUE NUMBER	
					Max 100Hz (mohm)	typ 100Hz (mOhm)	max 10KHz (mOhm)	55°C 100Hz (A)	85°C 100Hz (A)	Flat bottom	Mounting stud
47000	40	BC	51 x 105	0,32	11	8	8	25,2	18	AYX-HR473X040BC1	AYUX-HR473X040BC1
68000		CC	63 x 107	0,38	9	7	7	31,3	22,4	AYX-HR683X040CC1	AYUX-HR683X040CC1
100000		DC	76 x 106	0,46	7	5	6	38,4	27,4	AYX-HR104X040DC1	AYUX-HR104X040DC1
150000		DF	76 x 147	0,65	7	5	6	45,2	32,3	AYX-HR154X040DF1	AYUX-HR154X040DF1

CAP (μ F)	Rated Voltage (Vn)	Case Code	Φ x h (mm)	TG δ 100Hz	ESR	ESR	Z	I ripple	I ripple	CATALOGUE NUMBER	
					Max 100Hz (mOhm)	typ 100Hz (mOhm)	max 10KHz (mOhm)	55°C 100Hz (A)	85°C 100Hz (A)	Flat bottom	Mounting stud
22000	63	BC	51 x 105	0,24	17	13	12	19,9	14,2	AYX-HR223X063BC1	AYUX-HR223X063BC1
33000		CC	51 x 105	0,28	14	10	11	22,6	16,1	AYX-HR333X063BC1	AYUX-HR333X063BC1
47000		CC	63 x 107	0,30	10	8	8	29,3	20,9	AYX-HR473X063CC1	AYUX-HR473X063CC1
68000		DC	76 x 106	0,36	8	6	7	34,5	25,6	AYX-HR683X063DC1	AYUX-HR683X063DC1
100000		DF	76 x 147	0,40	6	5	5	47,1	33,6	AYX-HR104X063DF1	AYUX-HR104X063DF1

CAP (μ F)	Rated Voltage (Vn)	Case Code	Φ x h (mm)	TG δ 100Hz	ESR	ESR	Z	I ripple	I ripple	CATALOGUE NUMBER	
					Max 100Hz (mOhm)	typ 100Hz (mOhm)	max 10Khz (mOhm)	55°C 100Hz (A)	85°C 100Hz (A)	Flat bottom	Mounting stud
10000		BB	51 x 83	0,12	19	14	17	15,6	9	AYX-HR103X100BB1	AYUX-HR103X100BB1
10000	100	BC	51 x 105	0,10	16	12	9	20,8	14,9	AYX-HR103X100BC1	AYUX-HR103X100BC1
15000		BC	51 x 105	0,11	12	9	8	24	17,3	AYX-HR153X100BC1	AYUX-HR153X100BC1
22000		CC	63 x 107	0,15	11	8	7	29,3	20,2	AYX-HR223X100CC1	AYUX-HR223X100CC1
33000		DC	76 x 106	0,18	9	7	7	35,3	25,2	AYX-HR333X100DC1	AYUX-HR333X100DC1
33000		DF	76 x 147	0,16	8	6	7	42,8	30,5	AYX-HR333X100DF1	AYUX-HR333X100DF1
47000		DF	76 x 147	0,18	6	5	5	48,1	34,4	AYX-HR473X100DF1	AYUX-HR473X100DF1

CAP (μ F)	Rated Voltage (Vn)	Case Code	Φ x h (mm)	TG δ 100Hz	ESR	ESR	Z	I ripple	I ripple	CATALOGUE NUMBER	
					Max 100Hz (mOhm)	typ 100Hz (mOhm)	max 10Khz (mOhm)	55°C 100Hz (A)	85°C 100Hz (A)	Flat bottom	Mounting stud
4700	160	BC	51 x 105	0,10	34	25	21	14,3	10,2	AYX-HR472X160BC1	AYUX-HR472X160BC1
4700		CC	63 x 107	0,09	30	23	20	16,9	12,1	AYX-HR472X160CC1	AYUX-HR472X160CC1
6800		DC	76 x 106	0,10	23	18	16	21,5	15,3	AYX-HR682X160DC1	AYUX-HR682X160DC1
10000		DF	76 x 106	0,11	18	13	13	24,8	17,7	AYX-HR103X160DC1	AYUX-HR103X160DC1
15000		DF	76 x 147	0,12	13	10	11	33,3	23,8	AYX-HR153X160DF1	AYUX-HR153X160DF1
22000		DJ	76 x 217	0,14	10	8	8	45,1	32,2	AYX-HR223X160DJ1	AYUX-HR223X160DJ1
15000		EC	90 x 108	0,15	16	12	11	29,3	20,9	AYX-HR153X160EC1	AYUX-HR153X160EC1
22000		EF	90 x 149	0,15	11	8	8	40,3	28,8	AYX-HR223X160EF1	AYUX-HR223X160EF1

CAP (μ F)	Rated Voltage (Vn)	Case Code	Φ x h (mm)	TG δ 100Hz	ESR	ESR	Z	I ripple	I ripple	CATALOGUE NUMBER	
					Max 100Hz (mOhm)	typ 100Hz (mOhm)	max 10Khz (mOhm)	55°C 100Hz (A)	85°C 100Hz (A)	Flat bottom	Mounting stud
3300	200 (**)	BC	51 x 105	0,10	48	36	30	12,5	8,9	AYX-HR332X200BC1	AYUX-HR332X200BC1
4700		CC	63 x 107	0,10	34	25	21	16,8	12	AYX-HR472X200CC1	AYUX-HR472X200CC1
4700		DC	76 x 106	0,09	30	23	21	19,7	14,1	AYX-HR472X200DC1	AYUX-HR472X200DC1
6800		DC	76 x 106	0,10	23	18	16	22,5	16,1	AYX-HR682X200DC1	AYUX-HR682X200DC1
10000		DF	76 x 147	0,11	18	13	13	29,7	21,2	AYX-HR103X200DF1	AYUX-HR103X200DF1
15000		DF	76 x 147	0,12	13	10	10	34,9	24,9	AYX-HR153X200DF1	AYUX-HR153X200DF1
22000		DF	76 x 147	0,13	9	7	7	40,6	29	AYX-HR223M200DF1	AYUX-HR223M200DF1
22000		DK	76 x 168	0,12	9	7	7	45,1	32,2	AYX-HR223X200DK1	AYUX-HR223X200DK1
33000		DK	76 x 168	0,12	6	4	7	55,3	39,5	AYX-HR333X200DK1	AYUX-HR333X200DK1
15000		EC	90 x 108	0,14	15	11	12	31,8	22,7	AYX-HR153X200EC1	AYUX-HR153X200EC1
22000		EC	90 x 108	0,14	10	8	8	43,7	31,2	AYX-HR223X200EC1	AYUX-HR223X200EC1

(**)= \pm 20%

CAP (μ F)	Rated Voltage (Vn)	Case Code	Φ x h (mm)	TG δ 100Hz	ESR	ESR	Z	I ripple	I ripple	CATALOGUE NUMBER	
					Max 100Hz (mOhm)	typ 100Hz (mOhm)	max 10KHz (mOhm)	55°C 100Hz (A)	85°C 100Hz (A)	Flat bottom	Mounting stud
2200	250	BC	51 x 105	0,09	65	49	38	10,8	7,7	AYX-HR222X250BC1	AYUX-HR222X250BC1
3300		CC	63 x 107	0,10	48	36	29	14,1	10,1	AYX-HR332X250CC1	AYUX-HR332X250CC1
4700		DC	76 x 106	0,10	34	25	22	18,7	13,4	AYX-HR472X250DC1	AYUX-HR472X250DC1
6800		DC	76 x 106	0,10	23	18	16	22,5	16,1	AYX-HR682X250DC1	AYUX-HR682X250DC1
10000		DF	76 x 147	0,10	16	12	12	31,2	22,3	AYX-HR103X250DF1	AYUX-HR103X250DF1
15000		DJ	76 x 217	0,12	13	10	10	42,1	30,1	AYX-HR153X250DJ1	AYUX-HR153X250DJ1
22000		DJ	76 x 217	0,12	9	7	10	42,1	30,1	AYX-HR223M250DJ1	AYUX-HR223M250DJ1
10000		EC	90 x 108	0,13	21	16	14	26,9	19,2	AYX-HR103X250EC1	AYUX-HR103X250EC1
15000		EF	90 x 149	0,13	14	10	10	37,4	26,7	AYX-HR153X250EF1	AYUX-HR153X250EF1

(**)=+/-20%

CAP (μ F)	Rated Voltage (Vn)	Case Code	Φ x h (mm)	TG δ 100Hz	ESR	ESR	Z	I ripple	I ripple	CATALOGUE NUMBER	
					Max 100Hz (mOhm)	typ 100Hz (mOhm)	max 10KHz (mOhm)	55°C 100Hz (A)	85°C 100Hz (A)	Flat bottom	Mounting stud
1500	350	BC	51 x 105	0,08	85	64	51	9,4	6,7	AYX-HR152X350BC1	AYUX-HR152X350BC1
2200		CC	63 x 107	0,08	58	43	35	12,9	9,2	AYX-HR222X350CC1	AYUX-HR222X350CC1
3300		DC	76 x 106	0,08	39	29	24	17,5	12,5	AYX-HR332X350DC1	AYUX-HR332X350DC1
4700		DC	76 x 106	0,10	34	25	24	18,7	13,4	AYX-HR472X350DC1	AYUX-HR472X350DC1
4700		DF	76 x 147	0,08	27	20	17	23,9	17,1	AYX-HR472X350DF1	AYUX-HR472X350DF1
6800		DF	76 x 147	0,08	19	14	13	28,8	20,5	AYX-HR682X350DF1	AYUX-HR682X350DF1
6800		DJ	76 x 217	0,08	19	14	11	34,7	24,8	AYX-HR682X350DJ1	AYUX-HR682X350DJ1
10000		DF	76 x 147	0,11	17	13	10	30	21,4	AYX-HR103X350DF1	AYUX-HR103X350DF1
15000		DF	76 x 147	0,12	13	10	10	34,9	24,9	AYX-HR153M350DF1	AYUX-HR153M350DF1
18000		DF	76 x 147	0,12	11	8	9	38,2	37,3	AYX-HR183M350DF1	AYUX-HR183M350DF1
10000	(**)	DJ	76 x 217	0,10	16	12	10	37,7	26,9	AYX-HR103X350DJ1	AYUX-HR103X350DJ1
15000		DJ	76 x 217	0,10	11	8	10	46,1	32,9	AYX-HR153X350DJ1	AYUX-HR153X350DJ1
18000		DF	76 x 147	0,10	9	7	10	46,1	32,8	AYX-HR183M350DF1	AYUX-HR183M350DF1
6800		EC	90 x 108	0,11	26	19	17	24,1	17,2	AYX-HR682X350EC1	AYUX-HR682X350EC1
10000		EF	90 x 149	0,11	18	13	12	33,2	23,7	AYX-HR103X350EF1	AYUX-HR103X350EF1
18000		EF	90 x 149	0,12	11	8	8	46,7	33,6	AYX-HR183M350EF1	AYUX-HR183M350EF1
15000		EJ	90 x 222	0,11	12	9	7	48,2	34,4	AYX-HR153X350EJ1	AYUX-HR153X350EJ1
27000		EJ	90 x 222	0,11	6	5	5	58,4	41,7	AYX-HR273M350EJ1	AYUX-HR273M350EJ1

(**)=+/-20%

CAP (μ F)	Rated Voltage (Vn)	Case Code	Φ x h (mm)	TG δ 100Hz	ESR	ESR	Z	I ripple	I ripple	CATALOGUE NUMBER		
					Max 100Hz (mOhm)	typ 100Hz (mOhm)	max 10KHz (mOhm)	55°C 100Hz (A)	85°C 100Hz (A)	Flat bottom	Mounting stud	
1000	400	BC	51 x 105	0,08	127	96	78	7,7	5,5	AYX-HR102X400BC1	AYUX-HR102X400BC1	
1500		BC	51 x 105	0,08	85	64	50	9,4	6,7	AYX-HR152X400BC1	AYUX-HR152X400BC1	
2200		(**)	BC	51 x 105	0,09	65	49	46	10,2	7,3	AYX-HR222M400BC1	AYUX-HR222M400BC1
2200		(**)	CC	63 x 107	0,09	65	49	43	12,1	8,7	AYX-HR222X400CC1	AYUX-HR222X400CC1
2200			DC	76 x 106	0,08	58	43	34	14,3	10,2	AYX-HR222X400DC1	AYUX-HR222X400DC1
3300		(**)	CC	63 x 107	0,09	43	33	29	14,1	10,1	AYX-HR332M400CC1	AYUX-HR332M400CC1
3300			DC	76 x 106	0,09	43	33	27	16,5	11,8	AYX-HR332X400DC1	AYUX-HR332X400DC1
3300		(**)	DF	76 x 147	0,09	43	33	27	18,9	13,5	AYX-HR332X400DF1	AYUX-HR332X400DF1
4700			DC	76 x 106	0,10	34	25	21	17,7	12,7	AYX-HR472M400DC1	AYUX-HR472M400DC1
4700		(**)	DF	76 x 147	0,09	30	23	18	22,5	16,1	AYX-HR472X400DF1	AYUX-HR472X400DF1
6800			DF	76 x 147	0,07	16	12	16	24,4	17,4	AYX-HR682M400DF1	AYUX-HR682M400DF1
8200		(**)	DF	76 x 147	0,08	16	12	16	26,3	18,8	AYX-HR822M400DF1	AYUX-HR822M400DF1
6800			DJ	76 x 217	0,08	19	14	12	32,7	23,4	AYX-HR682X400DJ1	AYUX-HR682X400DJ1
10000		(**)	DJ	76 x 217	0,11	18	13	11	35,9	25,6	AYX-HR103X400DJ1	AYUX-HR103X400DJ1
4700			EN	90 x 65	0,11	37	28	25	20,1	14,3	AYX-HR472X400EN1	AYUX-HR472X400EN1
4700		(**)	EC	90 x 108	0,11	37	28	23	30,1	21,5	AYX-HR472X400EC1	AYUX-HR472X400EC1
8200			EF	90 x 149	0,11	21	16	14	33,2	23,7	AYX-HR822X400EF1	AYUX-HR822X400EF1
10000		(**)	EF	90 x 149	0,11	18	13	14	46,1	33	AYX-HR103X400EF1	AYUX-HR103X400EF1
15000			EJ	90 x 222	0,08	8	6	12	49,8	36	AYX-HR153X400EJ1	AYUX-HR153X400EJ1

(**)= \pm -20%

CAP (μ F)	Rated Voltage (Vn)	Case Code	Φ x h (mm)	TG δ 100Hz	ESR	ESR	Z	I ripple	I ripple	CATALOGUE NUMBER		
					Max 100Hz (mOhm)	typ 100Hz (mOhm)	max 10KHz (mOhm)	55°C 100Hz (A)	85°C 100Hz (A)	Flat bottom	Mounting stud	
1000	420	BC	51 x 105	0,08	127	96	78	7,7	5,5	AYX-HR102X420BC1	AYUX-HR102X420BC1	
1500		BC	51 x 105	0,08	85	64	50	9,4	6,7	AYX-HR152X420BC1	AYUX-HR152X420BC1	
1500		(**)	CC	63 x 107	0,08	85	64	50	10,6	7,6	AYX-HR152X420CC1	AYUX-HR152X420CC1
2200			CC	63 x 107	0,10	72	54	43	11,5	8,2	AYX-HR222X420CC1	AYUX-HR222X420CC1
2200		(**)	DC	76 x 106	0,08	58	43	34	14,3	10,2	AYX-HR222X420DC1	AYUX-HR222X420DC1
3300			DC	76 x 106	0,09	43	33	28	16,5	11,8	AYX-HR332X420DC1	AYUX-HR332X420DC1
3300		(**)	DF	76 x 147	0,09	43	33	27	18,9	13,5	AYX-HR332X420DF1	AYUX-HR332X420DF1
4700			DF	76 x 147	0,09	30	23	18	22,5	16,1	AYX-HR472X420DF1	AYUX-HR472X420DF1
6800		(**)	DF	76 x 147	0,07	16	12	12	24,4	17,5	AYX-HR682M420DF1	AYUX-HR682M420DF1
6800			DJ	76 x 217	0,09	21	16	12	32,7	23,4	AYX-HR682X420DJ1	AYUX-HR682X420DJ1
10000		(**)	DJ	76 x 217	0,09	14	11	11	39,4	28,1	AYX-HR103X420DJ1	AYUX-HR103X420DJ1
6800			EF	90 x 149	0,11	26	19	11	27,4	19,6	AYX-HR682X420EF1	AYUX-HR682X420EF1
15000		(**)	EJ	90 x 222	0,11	12	9	11	46,5	35,1	AYX-HR153M420EJ1	AYUX-HR153M420EJ1

(**)= \pm -20%

CAP (μ F)	Rated Voltage (Vn)	Case Code	Φ x h (mm)	TG δ 100Hz	ESR	ESR	Z	I ripple	I ripple	CATALOGUE NUMBER		
					Max 100Hz (mOhm)	typ 100Hz (mOhm)	max 10KHz (mOhm)	55°C 100Hz (A)	85°C 100Hz (A)	Flat bottom	Mounting stud	
1000	450	BC	51 x 105	0,10	159	119	88	6,9	4,9	AYX-HR102X450BC1	AYUX-HR102X450BC1	
1500		(**)	BC	51 x 105	0,10	106	80	88	8	5,7	AYX-HR152M450BC1	AYUX-HR152M450BC1
1500		CC	63 x 107	0,10	106	80	60	9,5	6,8	AYX-HR152X450CC1	AYUX-HR152X450CC1	
2200		CC	63 x 107	0,12	87	65	49	10,5	7,5	AYX-HR222X450CC1	AYUX-HR222X450CC1	
2200		DC	76 x 106	0,10	72	54	43	12,8	9,1	AYX-HR222X450DC1	AYUX-HR222X450DC1	
3300		DC	76 x 106	0,12	58	43	36	14,3	10,2	AYX-HR332X450DC1	AYUX-HR332X450DC1	
3300		DF	76 x 147	0,10	48	36	28	17,9	12,8	AYX-HR332X450DF1	AYUX-HR332X450DF1	
4700		DF	76 x 147	0,12	41	30	24	19,5	13,9	AYX-HR472X450DF1	AYUX-HR472X450DF1	
6800		(**)	DF	76 X 143	0,12	28	21	20	20,2	14,4	AYX-HR682M450DF1	AYUX-HR682M450DF1
6800		DJ	76 X 143	0,12	28	21	17	28,3	20,2	AYX-HR682X450DJ1	AYUX-HR682X450DJ1	
10000		DJ	76 x 217	0,12	19	14	20	32,5	22,8	AYX-HR103X450DJ1	AYUX-HR103X450DJ1	
4700		EC	90 x 108	0,12	41	30	25	21,8	15,6	AYX-HR472X450EC1	AYUX-HR472X450EC1	
6800		EF	90 x 149	0,12	28	21	17	26,2	18,7	AYX-HR682X450EF1	AYUX-HR682X450EF1	
10000		EJ	90 x 222	0,12	19	14	12	37,7	26,9	AYX-HR103X450EJ1	AYUX-HR103X450EJ1	
12000		(**)	EJ	90 x 222	0,12	16	12	12	40,5	26,9	AYX-HR123M450EJ1	AYUX-HR123M450EJ1

CAP (μ F)	Rated Voltage (Vn)	Case Code	Φ x h (mm)	TG δ 100Hz	ESR	ESR	Z	I ripple	I ripple	CATALOGUE NUMBER	
					max 100Hz (mOhm)	typ 100Hz (mOhm)	max 10KHz (mOhm)	55°C 100Hz (A)	85°C 100Hz (A)	Flat bottom	Mounting stud
1000	500	BC	51 x 105	0,13	207	155	124	6	4,3	AYX-HR102X500BC1	AYUX-HR102X500BC1
1500		CC	63 x 107	0,15	159	119	95	7,8	5,5	AYX-HR152X500CC1	AYUX-HR152X500CC1
2200		DC	76 x 106	0,18	130	98	78	9,5	6,8	AYX-HR222X500DC1	AYUX-HR222X500DC1
2200		DF	76 x 147	0,15	109	81	65	11,9	8,5	AYX-HR222X500DF1	AYUX-HR222X500DF1
3300		DF	76 x 147	0,11	53	40	52	13,4	9,5	AYX-HR332X500DF1	AYUX-HR332X500DF1

AS- / ASU SERIES

ALUMINIUM ELECTROLYTIC CAPACITORS LONG LIFE GRADE

Series	Capacitance range	Voltage range	Temperature range	Case Φ x H	Applications
AS ASU	100-330000	25-500	-40 °C , +85°C	35 x 59 76 x 217	Long life High reliability Telecom, Railways applications

MECHANICAL OUTLINES:

CASE: aluminium made
 TERMINALS:screw 5MA
 SEALING: hermetic by beading on an EPR gasket, housed on a resin cover
 PRESSURE RELEASE VENT: made in silicone-rubber
 SLEEVE: self-extinguishing thermoshrinkable sleeve
 SIZE: see enclosed drawings
 MOUNTING HARDWARE: see hardware section

SPECIFICATIONS	TEMPERATURE RANGE	CAPACITANCE
CECC 30300 IEC 384-4 ("long life grade") MIL C62D DIN 41240 / DIN 45910	Operating: -40 °C/ +85 °C Climatic Category : 40/85/56	Tolerance shall be within the following limits: -10% +30% (standard tolerance) or -20% + 20% (available on request)

LEAKAGE CURRENT:

After the rated voltage has been applied to the capacitor for 5 minutes the leakage current must be:

Maximum limit	at 25 °C	$I_f \leq 1.5 * \sqrt{C * V}$
Operating limit	at 25 °C:	$I_f \leq 1.0 * \sqrt{C * V}$

where I_f = leakage current (μ A)

C = capacitance (μ F)

V = rated voltage (V)

IMPORTANT

1) When using high-capacitance and high-voltage electrolytic capacitors it is important to remember that the inner part (the rolled section) is not insulated from can: between the negative pole and the aluminium can there is a variable and not defined resistance essentially due to the electrolyte used in capacitor manufacture.

SURGE VOLTAGE

Working Voltage	25	40	63	100	160	200	250	350	400	450	500
Surge Voltage	40	55	84	130	215	250	300	425	475	525	550

RIPPLE CURRENT:

the allowable values of ripple current in amperes, are related to temperature and frequency by the formula:

$$I_r = K_t * K_f * I_{r85}$$

where I_{r85} is the limit given by tables, referred to a temperature of 85 °C and to a frequency of 100 HZ and K_t or K_f are values here below tabulated:

°C	40	55	65	75	85
K_t	2.1	1.8	1.6	1.3	1.0

V_n Hz	Kf					
	V=50			50<V=300		
	Code Diameter A,B			Code Diameter C,D		
50	0.82	0.79	0.76	0.86	0.78	0.72
100	1	1	1	1	1	1
120	1.03	1.04	1.04	1.01	1.02	1.03
200	1.08	1.12	1.17	1.03	1.06	1.14
300	1.12	1.16	1.28	1.03	1.08	1.24
400	1.13	1.20	1.35	1.03	1.09	1.29
500	1.15	1.22	1.39	1.03	1.09	1.32
>1000	1.18	1.25	1.45	1.03	1.09	1.37

DIMENSIONS

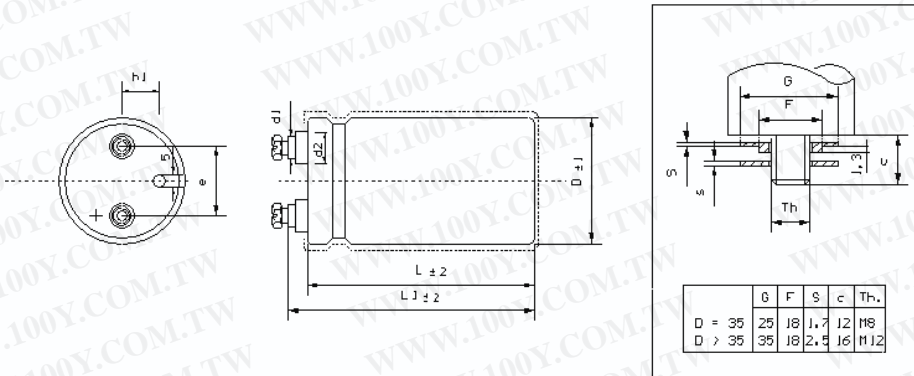

Insert Screw Thread = M5	Insert Screw Length (Terminal Code "-X") = 10 mm.
Insert Screw Torque Max. (M5) = 2 Nm.	Screw Torque For Hex Nuts M8 = 4 Nm.
Screw Torque For Hex Nuts M12 = 10 Nm.	

CASE CODE	$\Phi \times L$ (mm)	$l1$	$d1$ $\pm, -0.5$	$d2$ $\pm, -0.5$	$h1$	e	CASE CODE	$\Phi \times L$ (mm)	$l1$	$d1$ $\pm, -0.5$	$d2$ $\pm, -0.5$	$h1$	e
AA	35 x 59	57	8	12	8	12,7	DF	76 x 147	151	13	18	19	31.8
AB	35 X 79	86	8	12	8	12,7	DK	76 x 168	173	13	18	19	31.8
AC	35 X 105	109	8	12	8	12,7	DJ	76 x 217	222	13	18	19	31.8
BB	51 x 83	86	13	18	13	22.2	EC	90 x 108	112	17	23	19	31.8
BC	51 x 105	108	13	18	13	22.2	EF	90 x 149	153	17	23	19	31.8
CC	63 x 107	111	13	18	16	28.6	EJ	90 x 222	227	17	23	19	31.8
DC	76 x 107	111	13	18	19	31.8							

- STANDARD MOUNTING STUD HARDWARE - INSULATING PLASTIC WASHERS AND METALLIC NUT

EXPECTED LIFE AS A FUNCTION OF TEMPERATURE AND RIPPLE CURRENT

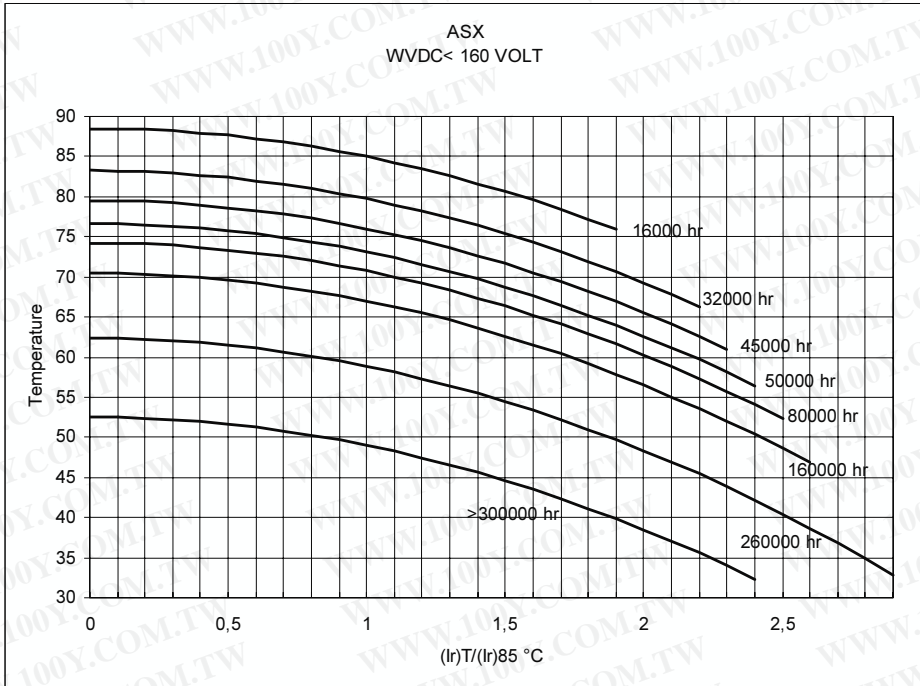

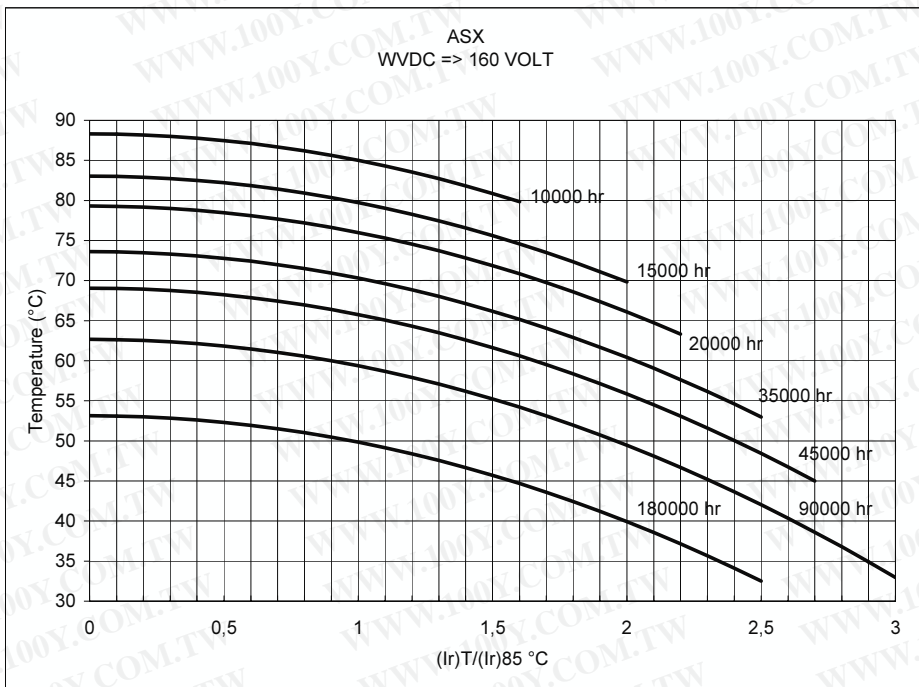

Expected life criteria : see introduction

CAP (μ F)	Rated Voltage (Vn)	Case Code	Φ x h (mm)	TG δ 100Hz	ESR	ESR	Z	I ripple	I ripple	CATALOGUE NUMBER	
					max 100Hz (mOhm)	typ. 100Hz (mOhm)	max 10KHz (mOhm)	55°C 100Hz (A)	85°C 100Hz (A)	Flat bottom	Mounting stud
6800	25	AA	35 x 59	0,22	52	41	38	9,0	4,9	ASM682X025AA1	ASUM682X025AA1
10000		AB	35 x 79	0,22	35	28	26	13,0	7,3	ASM103X025AB1	ASUM103X025AB1
15000		AC	35 x 105	0,22	23	19	17	18,0	10,2	ASM153X025AC1	ASUM153X025AC1
22000		BB	51 x 83	0,32	23	19	18	20,0	11,1	ASM223X025BB1	ASUM223X025BB1
33000		BC	51 x 105	0,36	17	14	14	26,0	14,5	ASM333X025BC1	ASUM333X025BC1
47000		CC	63 x 107	0,33	11	9	10	37,0	20,4	ASM473X025CC1	ASUM473X025CC1
68000		CC	63 x 107	0,39	9	7	8	41,0	22,6	ASM683X025CC1	ASUM683X025CC1
100000		DC	76 x 107	0,56	9	7	8	46,0	25,4	ASM104X025DC1	ASUM104X025DC1
150000		DF	76 x 147	0,75	8	6	8	55,0	30,8	ASM154X025DF1	ASUM154X025DF1

CAP (μ F)	Rated Voltage (Vn)	Case Code	Φ x h (mm)	TG δ 100Hz	ESR	ESR	Z	I ripple	I ripple	CATALOGUE NUMBER	
					max 100Hz (mOhm)	typ. 100Hz (mOhm)	max 10KHz (mOhm)	55°C 100Hz (A)	85°C 100Hz (A)	Flat bottom	Mounting stud
4700	40	AA	35 x 59	0,18	61	49	44	8,0	4,5	ASM472X040AA1	ASUM472X040AA1
6800		AB	35 x 79	0,21	49	39	35	11,0	6,2	ASM682X040AB1	ASUM682X040AB1
10000		AC	35 x 105	0,25	40	32	29	14,0	7,8	ASM103X040AC1	ASUM103X040AC1
15000		BB	51 x 83	0,27	29	23	21	18,0	10,0	ASM153X040BB1	ASUM153X040BB1
22000		BC	51 x 105	0,33	24	19	16	22,0	12,4	ASM223X040BC1	ASUM223X040BC1
33000		CC	63 x 107	0,35	17	14	12	30,0	16,6	ASM333X040CC1	ASUM333X040CC1
47000		CC	63 x 107	0,37	13	10	10	35,0	19,3	ASM473X040CC1	ASUM473X040CC1
68000		DC	76 x 107	0,42	10	8	8	44,0	24,2	ASM683X040DC1	ASUM683X040DC1
100000		DF	76 x 147	0,49	8	6	7	56,0	31,1	ASM104X040DF1	ASUM104X040DF1

CAP (μ F)	Rated Voltage (Vn)	Case Code	Φ x h (mm)	TG δ 100Hz	ESR	ESR	Z	I ripple	I ripple	CATALOGUE NUMBER	
					max 100Hz (mOhm)	typ. 100Hz (mOhm)	max 10KHz (mOhm)	55°C 100Hz (A)	85°C 100Hz (A)	Flat bottom	Mounting stud
3300	63	AA	35 x 59	0,12	58	46	40	8,0	4,7	ASM332X063AA1	ASUM332X063AA1
4700		AB	35 x 79	0,12	41	33	29	12,0	6,8	ASM472X063AB1	ASUM472X063AB1
6800		AC	35 x 105	0,12	28	22	20	17,0	9,3	ASM682X063AC1	ASUM682X063AC1
10000		BB	51 x 83	0,16	25	20	19	19,0	10,6	ASM103X063BB1	ASUM103X063BB1
15000		BC	51 x 105	0,16	17	14	14	26,0	14,7	ASM153X063BC1	ASUM153X063BC1
22000		CC	63 x 107	0,12	9	7	8	42,0	23,2	ASM223X063CC1	ASUM223X063CC1
33000		DC	76 x 107	0,16	8	6	8	49,0	27,3	ASM333X063DC1	ASUM333X063DC1
33000		DD	76 x 118	0,16	8	6	8	52,0	28,9	ASM333X063DD1	ASUM333X063DD1
47000		DC	76 x 107	0,18	6	5	6	55,0	30,8	ASM473X063DC1	ASUM473X063DC1
68000		DF	76 x 147	0,32	7	6	7	57,0	31,7	ASM683X063DF1	ASUM683X063DF1

CAP (μ F)	Rated Voltage (Vn)	Case Code	Φ x h (mm)	TG δ 100Hz	ESR	ESR	Z	I ripple	I ripple	CATALOGUE NUMBER	
					max 100Hz (mOhm)	typ. 100Hz (mOhm)	max 10KHz (mOhm)	55°C 100Hz (A)	85°C 100Hz (A)	Flat bottom	Mounting stud
6800	25	AA	35 x 59	0,22	52	41	38	9,0	4,9	ASM682X025AA1	ASUM682X025AA1
10000		AB	35 x 79	0,22	35	28	26	13,0	7,3	ASM103X025AB1	ASUM103X025AB1
15000		AC	35 x 105	0,22	23	19	17	18,0	10,2	ASM153X025AC1	ASUM153X025AC1
22000		BB	51 x 83	0,32	23	19	18	20,0	11,1	ASM223X025BB1	ASUM223X025BB1
33000		BC	51 x 105	0,36	17	14	14	26,0	14,5	ASM333X025BC1	ASUM333X025BC1
47000		CC	63 x 107	0,33	11	9	10	37,0	20,4	ASM473X025CC1	ASUM473X025CC1
68000		CC	63 x 107	0,39	9	7	8	41,0	22,6	ASM683X025CC1	ASUM683X025CC1
100000		DC	76 x 107	0,56	9	7	8	46,0	25,4	ASM104X025DC1	ASUM104X025DC1
150000		DF	76 x 147	0,75	8	6	8	55,0	30,8	ASM154X025DF1	ASUM154X025DF1

CAP (μ F)	Rated Voltage (Vn)	Case Code	Φ x h (mm)	TG δ 100Hz	ESR	ESR	Z	I ripple	I ripple	CATALOGUE NUMBER	
					max 100Hz (mOhm)	typ. 100Hz (mOhm)	max 10KHz (mOhm)	55°C 100Hz (A)	85°C 100Hz (A)	Flat bottom	Mounting stud
4700	40	AA	35 x 59	0,18	61	49	44	8,0	4,5	ASM472X040AA1	ASUM472X040AA1
6800		AB	35 x 79	0,21	49	39	35	11,0	6,2	ASM682X040AB1	ASUM682X040AB1
10000		AC	35 x 105	0,25	40	32	29	14,0	7,8	ASM103X040AC1	ASUM103X040AC1
15000		BB	51 x 83	0,27	29	23	21	18,0	10,0	ASM153X040BB1	ASUM153X040BB1
22000		BC	51 x 105	0,33	24	19	16	22,0	12,4	ASM223X040BC1	ASUM223X040BC1
33000		CC	63 x 107	0,35	17	14	12	30,0	16,6	ASM333X040CC1	ASUM333X040CC1
47000		CC	63 x 107	0,37	13	10	10	35,0	19,3	ASM473X040CC1	ASUM473X040CC1
68000		DC	76 x 107	0,42	10	8	8	44,0	24,2	ASM683X040DC1	ASUM683X040DC1
100000		DF	76 x 147	0,49	8	6	7	56,0	31,1	ASM104X040DF1	ASUM104X040DF1

CAP (μ F)	Rated Voltage (Vn)	Case Code	Φ x h (mm)	TG δ 100Hz	ESR	ESR	Z	I ripple	I ripple	CATALOGUE NUMBER	
					max 100Hz (mOhm)	typ. 100Hz (mOhm)	max 10KHz (mOhm)	55°C 100Hz (A)	85°C 100Hz (A)	Flat bottom	Mounting stud
3300	63	AA	35 x 59	0,12	58	46	40	8,0	4,7	ASM332X063AA1	ASUM332X063AA1
4700		AB	35 x 79	0,12	41	33	29	12,0	6,8	ASM472X063AB1	ASUM472X063AB1
6800		AC	35 x 105	0,12	28	22	20	17,0	9,3	ASM682X063AC1	ASUM682X063AC1
10000		BB	51 x 83	0,16	25	20	19	19,0	10,6	ASM103X063BB1	ASUM103X063BB1
15000		BC	51 x 105	0,16	17	14	14	26,0	14,7	ASM153X063BC1	ASUM153X063BC1
22000		CC	63 x 107	0,12	9	7	8	42,0	23,2	ASM223X063CC1	ASUM223X063CC1
33000		DC	76 x 107	0,16	8	6	8	49,0	27,3	ASM333X063DC1	ASUM333X063DC1
33000		DD	76 x 118	0,16	8	6	8	52,0	28,9	ASM333X063DD1	ASUM333X063DD1
47000		DC	76 x 107	0,18	6	5	6	55,0	30,8	ASM473X063DC1	ASUM473X063DC1
68000	DF	76 x 147	0,32	7	6	7	57,0	31,7	ASM683X063DF1	ASUM683X063DF1	

CAP (μ F)	Rated Voltage (Vn)	Case Code	Φ x h (mm)	TG δ 100Hz	ESR	ESR	Z	I ripple	I ripple	CATALOGUE NUMBER	
					max 100Hz (mOhm)	typ. 100Hz (mOhm)	max 10Khz (mOhm)	55°C 100Hz (A)	85°C 100Hz (A)	Flat bottom	Mounting stud
680	100	AA	35 x 59	0,10	234	187	150	4,0	2,3	ASM681X100AA1	ASUM681X100AA1
1000		AB	35 x 79	0,10	159	127	105	6,0	3,4	ASM102X100AB1	ASUM102X100AB1
1500		AB	35 x 79	0,10	106	85	71	8,0	4,2	ASM152X100AB1	ASUM152X100AB1
2200		AC	35 x 105	0,10	72	58	49	10,0	5,8	ASM222X100AC1	ASUM222X100AC1
3300		BB	51 x 83	0,12	58	46	41	13,0	7,0	ASM332X100BB1	ASUM332X100BB1
4700		BC	51 x 105	0,12	41	33	29	17,0	9,5	ASM472X100BC1	ASUM472X100BC1
6800		BC	51 x 105	0,12	28	22	21	21,0	11,4	ASM682X100BC1	ASUM682X100BC1
10000		CC	63 x 107	0,12	19	15	14	28,0	15,6	ASM103X100CC1	ASUM103X100CC1
15000		DC	76 x 107	0,13	14	11	11	37,0	20,4	ASM153X100DC1	ASUM153X100DC1
22000		DF	76 x 147	0,13	9	8	9	51,0	28,3	ASM223X100DF1	ASUM223X100DF1

CAP (μ F)	Rated Voltage (Vn)	Case Code	Φ x h (mm)	TG δ 100Hz	ESR	ESR	Z	I ripple	I ripple	CATALOGUE NUMBER	
					max 100Hz (mOhm)	typ. 100Hz (mOhm)	Max 10Khz (mOhm)	55°C 100Hz (A)	85°C 100Hz (A)	Flat bottom	Mounting stud
470	160	AA	35 x 59	0,09	305	244	206	4,0	2,0	ASM471X160AA1	ASUM471X160AA1
680		AB	35 x 79	0,09	211	169	142	5,0	3,0	ASM681X160AB1	ASUM681X160AB1
1000		AC	35 x 105	0,09	143	115	98	7,0	4,1	ASM102X160AC1	ASUM102X160AC1
1500		BB	51 x 83	0,10	106	85	73	9,0	5,2	ASM152X160BB1	ASUM152X160BB1
2200		BC	51 x 105	0,10	72	58	50	13,0	7,1	ASM222X160BC1	ASUM222X160BC1
3300		CC	63 x 107	0,10	48	39	34	18,0	9,8	ASM332X160CC1	ASUM332X160CC1
4700		DC	76 x 107	0,12	41	33	31	21,0	11,9	ASM472X160DC1	ASUM472X160DC1
6800		DF	76 x 147	0,12	28	22	21	29,0	16,4	ASM682X160DF1	ASUM682X160DF1
10000		DF	76 x 147	0,12	19	15	14	36,0	19,9	ASM103X160DF1	ASUM103X160DF1
15000		DF	76 x 147	0,12	13	10	12	40,5	22,4	ASM153X160DF1	ASUM153X160DF1

CAP (μ F)	Rated Voltage (Vn)	Case Code	Φ x h (mm)	TG δ 100Hz	ESR	ESR	Z	I ripple	I ripple	CATALOGUE NUMBER	
					max 100Hz (mOhm)	typ. 100Hz (mOhm)	max 10Khz (mOhm)	55°C 100Hz (A)	85°C 100Hz (A)	Flat bottom	Mounting stud
330	200	AA	35 x 59	0,08	386	309	248	3,0	1,8	ASM331X200AA1	ASUM331X200AA1
470		AB	35 x 79	0,08	271	217	181	5,0	2,6	ASM471X200AB1	ASUM471X200AB1
680		AC	35 x 105	0,08	187	150	125	6,0	3,6	ASM681X200AC1	ASUM681X200AC1
1000		BB	51 x 83	0,08	127	102	85	9,0	4,7	ASM102X200BB1	ASUM102X200BB1
1500		BC	51 x 105	0,08	85	68	59	12,0	6,6	ASM152X200BC1	ASUM152X200BC1
2200		CC	63 x 107	0,08	58	46	41	16,0	9,0	ASM222X200CC1	ASUM222X200CC1
3300		CC	63 x 107	0,09	43	35	32	19,0	10,4	ASM332X200CC1	ASUM332X200CC1
4700		DC	76 x 107	0,10	34	27	25	23,0	13,1	ASM472X200DC1	ASUM472X200DC1

CAP (μ F)	Rated Voltage (Vn)	Case Code	Φ x h (mm)	TG δ 100Hz	ESR max 100Hz (mOhm)	ESR typ. 100Hz (mOhm)	Z max 10Khz (mOhm)	I ripple 55°C 100Hz (A)	I ripple 85°C 100Hz (A)	CATALOGUE NUMBER	
										Flat bottom	Mounting stud
220	250	AA	35 x 59	0,07	507	405	323	3,0	1,6	ASM221X250AA1	ASUM221X250AA1
330		AB	35 x 79	0,08	386	309	215	4,0	2,2	ASM331X250AB1	ASUM331X250AB1
470		AC	35 x 105	0,08	271	217	165	5,0	3,0	ASM471X250AC1	ASUM471X250AC1
470		BB	51 x 83	0,08	271	217	176	6,0	3,3	ASM471X250BB1	ASUM471X250BB1
680		BB	51 x 83	0,08	187	150	124	7,0	3,9	ASM681X250BB1	ASUM681X250BB1
1000		BC	51 x 105	0,08	127	102	85	10,0	5,4	ASM102X250BC1	ASUM102X250BC1
1500		BC	51 x 105	0,08	85	68	58	12,0	6,6	ASM152X250BC1	ASUM152X250BC1
2200		CC	63 x 107	0,09	65	52	45	15,0	8,5	ASM222X250CC1	ASUM222X250CC1
3300		DC	76 x 107	0,10	48	39	34	20,0	10,9	ASM332X250DC1	ASUM332X250DC1
4700		DF	76 x 147	0,10	34	27	26	27,0	14,4	ASM472X250DF1	ASUM472X250DF1
6800		DJ	76 x 217	0,10	23	19	21	39,0	21,7	ASM682X250DJ1	ASUM682X250DJ1

CAP (μ F)	Rated Voltage (Vn)	Case Code	Φ x h (mm)	TG δ 100Hz	ESR max 100Hz (mOhm)	ESR typ. 100Hz (mOhm)	Z max 10Khz (mOhm)	I ripple 55°C 100Hz (A)	I ripple 85°C 100Hz (A)	CATALOGUE NUMBER	
										Flat bottom	Mounting stud
220	350	AB	35 x 79	0,06	434	347	371	3,0	1,9	ASM221X350AB1	ASUM221X350AB1
330		AC	35 x 105	0,07	338	270	248	5,0	2,5	ASM331X350AC1	ASUM331X350AC1
470		BB	51 x 83	0,07	220	176	180	6,0	3,3	ASM471X350BB1	ASUM471X350BB1
680		BC	51 x 105	0,07	164	131	124	8,0	4,4	ASM681X350BC1	ASUM681X350BC1
1000		BC	51 x 105	0,07	108	87	85	10,0	5,4	ASM102X350BC1	ASUM102X350BC1
1500		CC	63 x 107	0,08	81	65	66	13,0	7,0	ASM152X350CC1	ASUM152X350CC1
2200		DC	76 x 107	0,09	62	50	51	16,0	8,9	ASM222X350DC1	ASUM222X350DC1
3300		DF	76 x 147	0,09	41	33	35	22,0	12,5	ASM332X350DF1	ASUM332X350DF1
4700		DF	76 x 147	0,07	24	19	24	27,0	14,9	ASM472X350DF1	ASUM472X350DF1
6800		DJ	76 x 217	0,10	23	19	20	39,0	21,7	ASM682X350DJ1	ASUM682X350DJ1

CAP (μ F)	Rated Voltage (Vn)	Case Code	Φ x h (mm)	TG δ 100Hz	ESR max 100Hz (mOhm)	ESR typ. 100Hz (mOhm)	Z max 10Khz (mOhm)	I ripple 55°C 100Hz (A)	I ripple 85°C 100Hz (A)	CATALOGUE NUMBER	
										Flat bottom	Mounting stud
220	400	AB	35 x 79	0,08	579	463	369	3,0	1,8	ASM221X400AB1	ASUM221X400AB1
330		AC	35 x 105	0,08	386	309	246	5,0	2,5	ASM331X400AC1	ASUM331X400AC1
470		BB	51 x 79	0,10	339	271	219	5,0	2,9	ASM471X400BB1	ASUM471X400BB1
680		BC	51 x 105	0,10	234	187	151	7,0	4,0	ASM681X400BC1	ASUM681X400BC1
1000		CC	63 x 106	0,10	159	127	105	10,0	5,4	ASM102X400CC1	ASUM102X400CC1
1500		DC	76 x 107	0,10	106	85	72	13,0	7,4	ASM152X400DC1	ASUM152X400DC1
2200		DC	76 x 107	0,11	80	64	51	15,0	8,5	ASM222X400DC1	ASUM222X400DC1
2200		DF	76 x 147	0,10	72	58	51	18,0	10,2	ASM222X400DF1	ASUM222X400DF1
3300		DF	76 x 147	0,12	58	46	35	21,0	11,4	ASM332X400DF1	ASUM332X400DF1
4700		DF	76 x 147	0,12	41	33	35	24,8	13,5	ASM472X400DF1	ASUM472X400DF1
6800		DJ	76 x 217	0,12	28	22	26	30,0	16,4	ASM682X400DJ1	ASUM682X400DJ1

CAP (μ F)	Rated Voltage (Vn)	Case Code	Φ x h (mm)	TG δ 100Hz	ESR	ESR	Z	I ripple	I ripple	CATALOGUE NUMBER	
					max 100Hz (mOhm)	typ. 100Hz (mOhm)	max 10Khz (mOhm)	55°C 100Hz (A)	85°C 100Hz (A)	Flat bottom	Mounting stud
150	450	AB	35 x 79	0,08	849	679	593	3,0	1,5	ASM151X450AB1	ASUM151X450AB1
220		AC	35 x 105	0,08	579	463	369	4,0	2,1	ASM221X450AC1	ASUM221X450AC1
330		AC	35 x 105	0,08	386	309	246	5,0	2,5	ASM331X450AC1	ASUM331X450AC1
470		BB	51 x 79	0,10	339	271	219	5,0	2,9	ASM471X450BB1	ASUM471X450BB1
680		BC	51 x 105	0,10	234	187	151	7,0	4,0	ASM681X450BC1	ASUM681X450BC1
1000		CC	63 x 106	0,10	159	127	105	10,0	5,4	ASM102X450CC1	ASUM102X450CC1
1500		DC	76 x 107	0,10	106	85	72	13,0	7,4	ASM152X450DC1	ASUM152X450DC1
2200		DC	76 x 107	0,10	72	58	51	16,0	8,9	ASM222X450DC1	ASUM222X450DC1
2200		DF	76 x 147	0,10	72	58	49	18,0	10,2	ASM222X450DF1	ASUM222X450DF1
3300		DF	76 x 147	0,12	58	46	39	21,0	11,4	ASM332X450DF1	ASUM332X450DF1
4700		DJ	76 x 217	0,12	41	33	29	30,0	16,4	ASM472X450DJ1	ASUM472X450DJ1
5600		DF	76 x 147	0,12	34	27	29	30,0	16,4	ASM562X450DF1	ASUM562X450DF1
5600		DJ	76 x 217	0,13	37	30	28	31,0	17,2	ASM562X450DJ1	ASUM562X450DJ1

CAP (μ F)	Rated Voltage (Vn)	Case Code	Φ x h (mm)	TG δ 100Hz	ESR	ESR	Z	I ripple	I ripple	CATALOGUE NUMBER	
					max 100Hz (mOhm)	typ. 100Hz (mOhm)	max 10Khz (mOhm)	55°C 100Hz (A)	85°C 100Hz (A)	Flat bottom	Mounting stud
1000	500	BC	51 X 105	0,10	159	127	98	8,0	4,2	ASM102X500BC1	ASUM102X500BC1
1500		DC	76 x 107	0,10	106	85	74	11,0	6,0	ASM152X500DC1	ASUM152X500DC1
2200		DF	76 x 147	0,10	72	58	47	15,0	8,3	ASM222X500DF1	ASUM222X500DF1
3300		DF	76 x 147	0,10	48	39	27	16,0	9,1	ASM332X500DF1	ASUM332X500DF1
4700		DF	76 x 147	0,08	27	22	31	27,0	15,4	ASM472M500DF1	ASUM472M500DF1
4700		EF	76 X 217	0,08	27	22	31	30,1	17,2	ASM472M500EF1	ASUM472M500EF1

AZ- / AZU- SERIES

ALUMINIUM ELECTROLYTIC CAPACITORS HIGH TEMPERATURE

Series	Capacitance range	Voltage range	Temperature range	Case Φ x H	Applications
<u>AZ</u> <u>AZU</u>	150-6800	100-450	-25°C, +105°C	51 x 105 76 x 220	Wide temperature range Long life High reliability Telecom, Railways applications

MECHANICAL OUTLINES:

CASE: aluminium made

TERMINALS: screw inserts with insulating shoulder

SEALING: hermetic by beading on an EPR gasket, housed on a resin cover

PRESSURE RELEASE VENT: made in silicone-rubber

SLEEVE: self-extinguishing thermo shrinkable sleeve

SIZE: see enclosed drawings

MOUNTING HARDWARE: see hardware section

SPECIFICATIONS	TEMPERATURE RANGE	CAPACITANCE
CECC 30300 IEC 384-4 ("long life grade") MIL C62D DIN 41240 / DIN 45910	Operating: -25 °C/ +105 °C Climatic Category 25/105/86	Tolerance shall be within the following limits: -10% +30% (standard tolerance) or -20% + 20% (available on request)

LEAKAGE CURRENT:

After the rated voltage has been applied to the capacitor for 5 minutes the leakage current must be:

Maximum limit	at 25 °C	$I_f \leq 1.5 \sqrt{C \cdot V}$
Operating limit	at 25 °C:	$I_f \leq 1.3 \sqrt{C \cdot V}$

Where I_f = leakage current (μ A)

C = capacitance (μ F)

V = rated voltage (V)

IMPORTANT

1) When using high-capacitance and high-voltage electrolytic capacitors it is important to remember that the inner part (the rolled section) is not insulated from can: between the negative pole and the aluminium can there is a variable and not defined resistance essentially due to the electrolyte used in capacitor manufacture.

SURGE VOLTAGE:

Working Voltage	100	160	200	250	315	400	420	450
Surge Voltage	115	185	230	290	347	385	460	490

RIPPLE CURRENT:

the allowable values of ripple current in amperes, are related to temperature and frequency by the formula:

$$I_r = K_t * K_f * I_{r105^\circ}$$

where I_{r105° is the limit given by tables, referred to a temperature of 105°C and to a frequency of 100 Hz and K_t or K_f are values here below tabulated:

Note. Ripple current is function of the capacitance tolerance

°C	40	55	65	75	85	95	105
K_t	2.5	2.4	2.2	2.0	1.8	1.3	1.0

Vn	Hz	50	100	300	400	500	>1kHz
V>250	K_f	0.88	1.00	1.20	1.25	1.35	1.40

DIMENSIONS

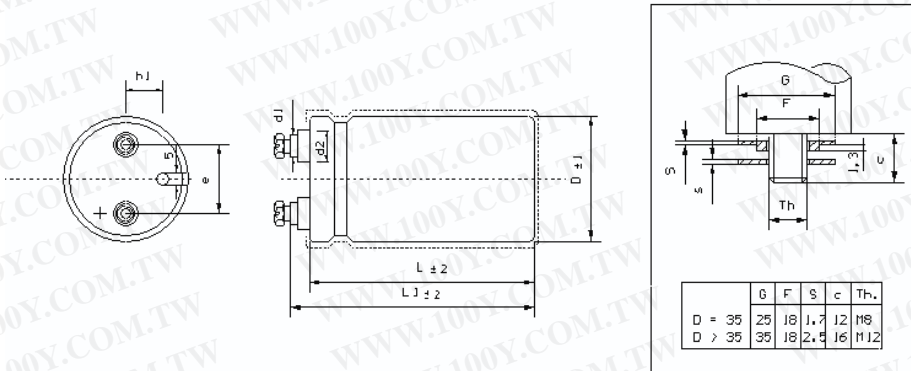

Insert Screw Thread (D= 51, 63, 76) = M5	Insert Screw Length = 10 mm.
Insert Screw Torque Max (M5) = 2 Nm.	Screw Torque For Hex Nuts M12 = 10 Nm.

CASE CODE	Φ X L (mm)	l1	d1 +,-0.5	d2 +,-0.5	h1	e	CASE CODE	Φ X L (mm)	l1	d1 +,-0.5	d2 +,-0.5	h1	e
BC	51 x 105	109	13	18	13	22.2							
CC	63 x 107	111	13	18	16	28.6							
DC	76 x 107	111	13	18	19	31.8							
DF	76 x 147	151	13	18	19	31.8							
DJ	76 x 217	222	13	18	19	31.8							

- STANDARD MOUNTING STUD HARDWARE - INSULATING PLASTIC WASHERS AND METALLIC NUT

EXPECTED LIFE AS A FUNCTION OF TEMPERATURE AND RIPPLE CURRENT

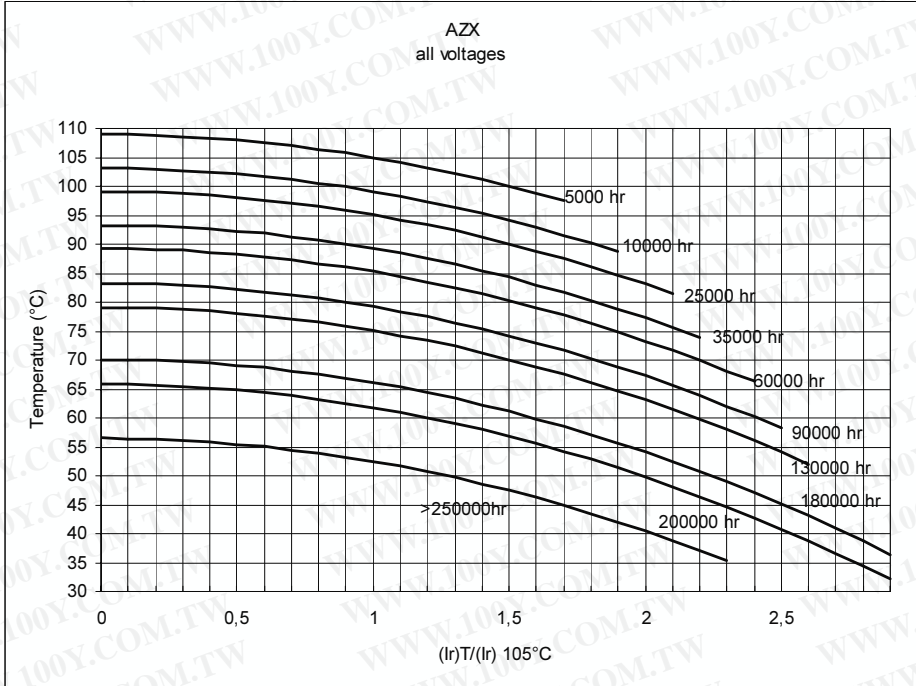

Expected life criteria : see introduction

CAP (μ F)	Rated Voltage (Vn)	Case Code	Φ x h (mm)	TG δ 100 Hz	ESR max 100 Hz (mOhm)	ESR typ. 100 Hz (mOhm)	Z max 10 KHz (mOhm)	Ripple 85°C 100 Hz (A)	Ripple 105°C 100 Hz (A)	CATALOGUE NUMBER	
										Flat bottom	Mounting stud
10000	100	BC	51 x 105	0,10	16	12	40	19,0	10,3	AZX103M100BC1	AZUX103M100BC1
15000		CC	63 x 107	0,10	11	8	10	26,0	14,2	AZX153M100CC1	AZUX153M100CC1
22000		DC	76 x 107	0,12	9	7	8	32,0	17,7	AZX223M100DC1	AZUX223M100DC1
33000		DF	76 x 147	0,12	6	4	6	45,0	24,8	AZX333M100DF1	AZUX333M100DF1

CAP (μ F)	Rated Voltage (Vn)	Case Code	Φ x h (mm)	TG δ 100 Hz	ESR max 100 Hz (mOhm)	ESR typ. 100 Hz (mOhm)	Z max 10 KHz (mOhm)	Ripple 85°C 100 Hz (A)	Ripple 105°C 100 Hz (A)	CATALOGUE NUMBER	
										Flat bottom	Mounting stud
2200	160	BC	51 x 105	0,11	80	60	68	9,0	4,8	AZX222M160BC1	AZUX222M160BC1
3300		BC	51 x 105	0,11	53	40	49	10,0	5,7	AZX332M160BC1	AZUX332M160BC1
4700		CC	63 x 107	0,11	37	28	34	14,0	7,6	AZX472M160CC1	AZUX472M160CC1
6800		DC	76 x 107	0,11	26	19	23	18,0	10,2	AZX682M160DC1	AZUX682M160DC1
10000		DF	76 x 147	0,11	18	13	16	25,0	14,1	AZX103M160DF1	AZUX103M160DF1
15000		DF	76 x 147	0,12	13	10	11	30,0	16,7	AZX153M160DF1	AZUX153M160DF1

CAP (μ F)	Rated Voltage (Vn)	Case Code	Φ x h (mm)	TG δ 100 Hz	ESR max 100 Hz (mOhm)	ESR typ. 100 Hz (mOhm)	Z max 10 KHz (mOhm)	Ripple 85°C 100 Hz (A)	Ripple 105°C 100 Hz (A)	CATALOGUE NUMBER	
										Flat bottom	Mounting stud
2200	200	BC	51 x 105	0,09	65	49	61	10,0	5,4	AZX222M200BC1	AZUX222M200BC1
3300		CC	63 x 107	0,09	43	33	40	13,0	7,5	AZX332M200CC1	AZUX332M200CC1
4700		DC	76 x 107	0,09	30	23	28	18,0	10,0	AZX472M200DC1	AZUX472M200DC1
6800		DF	76 x 147	0,09	21	16	18	25,0	13,7	AZX682M200DF1	AZUX682M200DF1
10000		DF	76 x 147	0,09	14	11	13	30,0	16,6	AZX103M200DF1	AZUX103M200DF1

CAP (μ F)	Rated Voltage (Vn)	Case Code	Φ x h (mm)	TG δ 100 Hz	ESR max 100 Hz (mOhm)	ESR Typ. 100 Hz (mOhm)	Z max 10 KHz (mOhm)	Ripple 85°C 100 Hz (A)	Ripple 105°C 100 Hz (A)	CATALOGUE NUMBER	
										Flat bottom	Mounting stud
1500	250	BC	51 x 105	0,09	96	72	77	8	4,7	AZX152M250BC1	AZUX152M250BC1
2200		CC	63 x 107	0,09	65	49	53	12	6,4	AZX222M250CC1	AZUX222M250CC1
3300		DC	76 x 107	0,09	43	33	35	16	8,8	AZX332M250DC1	AZUX332M250DC1
4700		DF	76 x 147	0,09	30	23	25	21	11,9	AZX472M250DF1	AZUX472M250DF1
6800		DJ	76 x 217	0,09	21	16	17	31	17,3	AZX682M250DJ1	AZUX682M250DJ1
10000		DJ	76 x 217	0,09	14	11	11	38	21,0	AZX103M250DJ1	AZUX103M250DJ1

CAP (μ F)	Rated Voltage (Vn)	Case Code	Φ x h (mm)	TG δ 100 Hz	ESR max	ESR Typ.	Z max	ripple 85°C	ripple 105°C	CATALOGUE NUMBER	
					100 Hz (mOhm)	100 Hz (mOhm)	10 KHz (mOhm)	100 Hz (A)	100 Hz (A)	Flat bottom	Mounting stud
1500	350	BC	51 x 105	0,07	74	56	62	0,0	5,3	AZX152M350BC1	AZUX152M350BC1
2200		CC	63 x 107	0,07	51	38	42	13,0	7,2	AZX222M350CC1	AZUX222M350CC1
3300		DC	76 x 107	0,07	34	25	28	18,0	9,8	AZX332M350DC1	AZUX332M350DC1
4700		DF	76 x 147	0,07	24	18	20	24,0	13,3	AZX472M350DF1	AZUX472M350DF1
6800		DF	76 x 147	0,07	16	12	20	27,0	14,8	AZX682M350DF1	AZUX682M350DF1
6800		DJ	76 x 217	0,07	16	12	28	35,0	19,4	AZX682M350DJ1	AZUX682M350DJ1
10000		DJ	76 x 217	0,07	11	8	14	42,0	23,5	AZX103M350DJ1	AZUX103M350DJ1

CAP (μ F)	Rated Voltage (Vn)	Case Code	Φ x h (mm)	TG δ 100 Hz	ESR max	ESR Typ.	Z Max	ripple 85°C	ripple 105°C	CATALOGUE NUMBER	
					100 Hz (mOhm)	100 Hz (mOhm)	10 KHz (mOhm)	100 Hz (A)	100 Hz (A)	Flat bottom	Mounting stud
1000	400	BC	51 x 105	0,07	111	84	92	8,0	4,3	AZX102M400BC1	AZUX102M400BC1
1500		CC	63 x 107	0,07	74	56	62	11,0	5,9	AZX152M400CC1	AZUX152M400CC1
2200		DC	76 x 147	0,07	51	38	42	14,0	8,0	AZX222M400DC1	AZUX222M400DC1
3300		DF	76 x 147	0,07	34	25	28	20,0	11,2	AZX332M400DF1	AZUX332M400DF1
4700		DF	76 x 147	0,07	24	18	20	24,0	13,3	AZX472M400DF1	AZUX472M400DF1
6800		DJ	76 x 217	0,07	16	12	14	35,0	19,4	AZX682M400DJ1	AZUX682M400DJ1

CAP (μ F)	Rated Voltage (Vn)	Case Code	Φ x h (mm)	TG δ 100 Hz	ESR max	ESR Typ.	Z max	ripple 85°C	ripple 105°C	CATALOGUE NUMBER	
					100 Hz (mOhm)	100 Hz (mOhm)	10 KHz (mOhm)	100 Hz (A)	100 Hz (A)	Flat bottom	Mounting stud
1000	450	BC	51 x 105	0,08	127	96	80	8,0	4,3	AZX102M450BC1	AZUX102M450BC1
1500		CC	63 x 107	0,08	85	64	54	11,0	5,9	AZX152M450CC1	AZUX152M450CC1
2200		DC	76 x 107	0,08	58	43	54	14,0	8,0	AZX222M450DC1	AZUX222M450DC1
2200		DF	76 x 147	0,08	58	43	37	16,0	9,1	AZX222M450DF1	AZUX222M450DF1
3300		DF	76 x 147	0,08	39	29	30	20,0	11,2	AZX332M450DF1	AZUX332M450DF1
4700		DJ	76 x 217	0,08	27	20	10	29,0	16,1	AZX472M450DJ1	AZUX472M450DJ1

AT-/ATU- SERIES

ALUMINIUM ELECTROLYTIC CAPACITORS LONG LIFE GRADE

Series	Capacitance range	Voltage range	Temperature Range	Case Φ x H	Applications
AT ATU	220-150000	25 - 350	-55°C, +105°C	35 x 56 76 x 217	Extended temperature range High surge voltage High reliability Telecom, Railways applications

MECHANICAL OUTLINES:

CASE: aluminium made

TERMINALS: standard screw inserts

SEALING: hermetic by beading on a SILICON gasket, housed on a resin that can withstand high temperature without sensible mechanical or chemical wear-out

PRESSURE RELEASE VENT: made in silicone-rubber

SLEEVE: self-extinguishing thermoshrinkable sleeve

SIZE: see enclosed drawings

MOUNTING HARDWARE: see hardware section

SPECIFICATIONS	TEMPERATURE RANGE	CAPACITANCE
CECC 30300 IEC 384-4 ("long life grade") DIN 45910 p.128	Operating: -55 °C/ +105 °C Climatic Category (IEC 68): 55/105/56	Tolerance shall be within the following limits: -10% +30%

LEAKAGE CURRENT:

After the rated voltage has been applied to the capacitor for 5 minutes the leakage current must be:

Maximum limit	at 25 °C	$I_f \leq 1.3 \cdot \sqrt{C \cdot V}$
Operating limit	at 25 °C:	$I_f \leq 1.2 \cdot \sqrt{C \cdot V}$

where I_f = leakage current (μ A)

C = capacitance (μ F)

V = rated voltage (V)

IMPORTANT:

1) When using high-capacitance and high-voltage electrolytic capacitors it is important to remember that the inner part (the rolled section) is not insulated from can: between the negative pole and the aluminium can there is a variable and not defined resistance essentially due to the electrolyte used in capacitor manufacture.

SURGE VOLTAGE:

Working Voltage	63	100	160	200	250	350
Surge Voltage	84	130	215	250	300	425

RIPPLE CURRENT:

the allowable values of ripple current in amperes, are related to temperature and frequency by the formula:

$$I_r = K_t * K_f * I_{r105}$$

where I_{r105} is the limit given by tables, referred to a temperature of 105°C and to a frequency of 100 Hz and K_t or K_f are values here below tabulated:

°C	40	55	65	75	85	95	105
K_t	2.6	2.5	2.3	2.1	1.8	1.3	1.0

V_n Hz	Kf					
	V ≤ 50		50 < V ≤ 300		V > 300	
	Diameter Code A,B			Diameter Code C,D		
50	0.82	0.79	0.76	0.86	0.87	0.78
100	1	1	1	1	1	1
120	1.02	1.04	1.04	1.01	1.02	1.05
200	1.08	1.12	1.17	1.03	1.06	1.14
300	1.12	1.16	1.28	1.03	1.08	1.24
400	1.12	1.20	1.26	1.03	1.09	1.31
500	1.15	1.22	1.39	1.03	1.09	1.32
>1000	1.17	1.25	1.47	1.03	1.09	1.41

DIMENSIONS

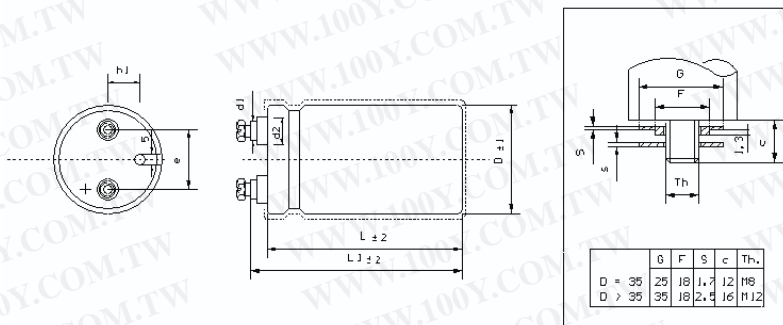

Insert Screw Thread = M5	Insert Screw Length = 10 mm.
Insert Screw Torque Max. (M5) = 2 Nm.	Screw Torque For Hex Nuts M8 = 4 Nm.
Screw Torque For Hex Nuts M12 = 10 Nm.	

CASE CODE	Φ X L (mm)	l1	d1 ±0.5	d2 ±0.5	h1	e	CASE CODE	Φ X L (mm)	l1	d1 ±0.5	d2 ±0.5	h1	e
							DF	76 x 147	151	13	18	19	31.8
							DK	76 x 168	173	13	18	19	31.8
AC	35 X 105	109	8	12	8	12.7	DJ	76 x 217	222	13	18	19	31.8
BB	51 x 79	86	13	18	13	22.2	EC	90 x 108	112	17	23	19	31.8
BC	51 x 105	108	13	18	13	22.2	EF	90 x 149	153	17	23	19	31.8
CC	63 x 107	111	13	18	16	28.6	EJ	90 x 222	227	17	23	19	31.8
DC	76 x 107	111	13	18	19	31.8							

- STANDARD MOUNTING STUD HARDWARE: - INSULATING PLASTIC WASHERS AND METALLIC NUT

EXPECTED LIFE AS A FUNCTION OF TEMPERATURE AND RIPPLE CURRENT

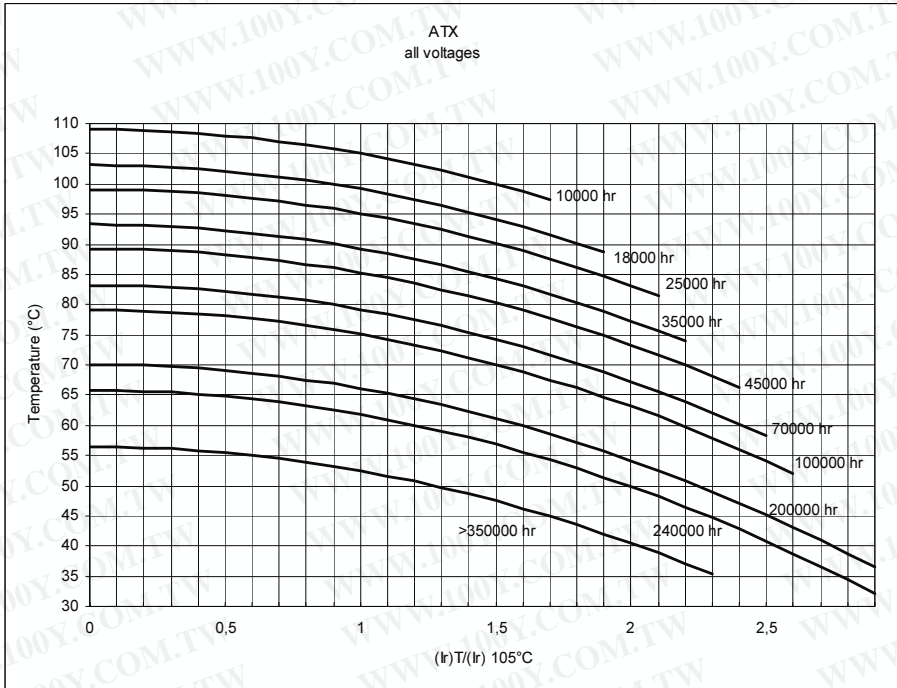

Expected life criteria : see introduction

CAP (μ F)	Rated Voltage (Vn)	Case Code	Φ x h (mm)	TG δ 100 Hz	ESR max 100 Hz (mOhm)	ESR typ. 100 Hz (mOhm)	Z max 10 KHz (mOhm)	ripple 75°C 100 Hz (A)	ripple 105°C 100 Hz (A)	CATALOGUE NUMBER	
										Flat bottom	Mounting stud
4700	63	AC	35 x 105	0,11	37	28	28	8,8	4,2	ATX472X100AC1	ATUX472X100AC1
6800		BB	51 x 79	0,12	28	21	22	11,0	5,2	ATX682X100BB1	ATUX682X100BB1
10000		BC	51 x 105	0,13	21	16	17	14,3	6,8	ATX103X100BC1	ATUX103X100BC1
15000		CC	63 x 105	0,14	15	11	13	19,1	9,1	ATX153X100CC1	ATUX153X100CC1
22000		DC	76 x 106	0,16	12	9	11	23,8	11,3	ATX223X100DC1	ATUX223X100DC1
33000		DF	76 x 147	0,18	9	7	8	33,3	15,8	ATX333X100DF1	ATUX333X100DF1

CAP (μ F)	Rated Voltage (Vn)	Case Code	Φ x h (mm)	TG δ 100 Hz	ESR max 100 Hz (mOhm)	ESR typ. 100 Hz (mOhm)	Z max 10 KHz (mOhm)	ripple 75°C 100 Hz (A)	ripple 105°C 100 Hz (A)	CATALOGUE NUMBER	
										Flat bottom	Mounting stud
1000	100	AB	35 x 79	0,07	111	84	80	4,5	2,1	ATX102X100AB1	ATUX102X100AB1
1500		AB	35 x 79	0,07	74	56	54	5,5	2,6	ATX152X100AB1	ATUX152X100AB1
2200		AC	35 x 105	0,07	51	38	37	7,5	3,6	ATX222X100AC1	ATUX222X100AC1
3300		BB	51 x 79	0,08	39	29	30	9,3	4,4	ATX332X100BB1	ATUX332X100BB1
4700		BC	51 x 105	0,08	27	20	21	12,7	6,0	ATX472X100BC1	ATUX472X100BC1
6800		CC	63 x 105	0,08	19	14	15	17,0	8,1	ATX682X100CC1	ATUX682X100CC1
10000		DC	51 x 105	0,10	16	12	13	20,6	9,8	ATX103X100DC1	ATUX103X100DC1
15000		DF	63 x 105	0,10	11	8	9	28,4	13,5	ATX153X100DF1	ATUX153X100DF1

CAP (μ F)	Rated Voltage (Vn)	Case Code	Φ x h (mm)	TG δ 100 Hz	ESR max 100 Hz (mOhm)	ESR typ. 100 Hz (mOhm)	Z max 10 KHz (mOhm)	ripple 75°C 100 Hz (A)	ripple 105°C 100 Hz (A)	CATALOGUE NUMBER	
										Flat bottom	Mounting stud
1000	160	AC	35 x 105	0,07	111	84	81	5,0	2,4	ATX102X160AC1	ATUX102X160AC1
1500		BB	51 x 79	0,07	74	56	54	6,7	3,2	ATX152X160BB1	ATUX152X160BB1
2200		BC	51 x 105	0,08	58	43	37	8,6	4,1	ATX222X160BC1	ATUX222X160BC1
3300		BC	51 x 105	0,08	39	29	30	11,9	5,6	ATX332X160BC1	ATUX332X160BC1
4700		CC	63 x 105	0,08	27	20	21	15,9	7,5	ATX472X160CC1	ATUX472X160CC1
6800		DC	76 x 106	0,08	19	14	15	18,9	9,0	ATX682X160DC1	ATUX682X160DC1
10000		DF	76 x 147	0,09	14	11	13	25,2	12,0	ATX103X160DF1	ATUX103X160DF1
15000		DJ	76 x 147	0,19	20	15	10	28,4	13,5	ATX153X160DJ1	ATUX153X160DJ1

CAP (μ F)	Rated Voltage (Vn)	Case Code	Φ x h (mm)	TG δ 100 Hz	ESR max 100 Hz (mOhm)	ESR typ. 100 Hz (mOhm)	Z max 10 KHz (mOhm)	Ripple 75°C 100 Hz (A)	Ripple 105°C 100 Hz (A)	CATALOGUE NUMBER	
										Flat bottom	Mounting stud
680	200	AC	35 x 105	0,06	141	105	99	4,5	2,1	ATX681X200AC1	ATUX681X200AC1
1000		BB	51 x 79	0,06	96	72	70	5,9	2,8	ATX102X200BB1	ATUX102X200BB1
1500		BB	51 x 79	0,07	74	56	54	6,7	3,2	ATX152X200BB1	ATUX152X200BB1
2200		BC	51 x 105	0,07	51	38	38	9,2	4,4	ATX222X200BC1	ATUX222X200BC1
3300		CC	63 x 105	0,07	34	25	26	12,7	6,0	ATX332X200CC1	ATUX332X200CC1
4700		DC	76 x 106	0,07	24	18	18	16,8	8,0	ATX472X200DC1	ATUX472X200DC1
6800		DF	76 x 147	0,08	19	14	16	21,6	10,3	ATX682X200DF1	ATUX682X200DF1
10000		DJ	76 x 147	0,10	16	12	14	23,5	11,2	ATX103X200DJ1	ATUX103X200DJ1

CAP (μ F)	Rated Voltage (Vn)	Case Code	Φ x h (mm)	TG δ 100 Hz	ESR max 100 Hz (mOhm)	ESR typ. 100 Hz (mOhm)	Z max 10 KHz (mOhm)	Ripple 75°C 100 Hz (A)	Ripple 105°C 100 Hz (A)	CATALOGUE NUMBER	
										Flat bottom	Mounting stud
680	250	AC	35 x 105	0,07	164	123	118	4,2	2,0	ATX681X250AC1	ATUX681X250AC1
1000		BB	51 x 105	0,07	111	84	80	5,5	2,6	ATX102X250BB1	ATUX102X250BB1
1500		BC	51 x 105	0,07	74	56	54	7,6	2,6	ATX152X250BC1	ATUX152X250BC1
2200		CC	63 x 105	0,08	58	43	44	9,7	4,6	ATX222X250CC1	ATUX222X250CC1
3300		DC	76 x 106	0,08	39	29	30	13,2	6,3	ATX332X250DC1	ATUX332X250DC1
4700		DF	76 x 147	0,08	27	20	22	18,1	8,6	ATX472X250DF1	ATUX472X250DF1
6800		DJ	76x217	0,10	23	18	15	19,6	9,3	ATX682X250DJ1	ATUX682X250DJ1

CAP (μ F)	Rated Voltage (Vn)	Case Code	Φ x h (mm)	TG δ 100 Hz	ESR max 100 Hz (mOhm)	ESR typ. 100 Hz (mOhm)	Z max 10 KHz (mOhm)	Ripple 75°C 100 Hz (A)	Ripple 105°C 100 Hz (A)	CATALOGUE NUMBER	
										Flat bottom	Mounting stud
330	350	AC	35 x 105	0,08	386	290	272	2,7	1,3	ATX331X350AC1	ATUX331X350AC1
470		BB	51 x 105	0,08	271	203	192	3,5	1,7	ATX471X350BB1	ATUX471X350BB1
680		BC	51 x 105	0,08	187	141	132	4,8	2,3	ATX681X350BC1	ATUX681X350BC1
1000		BC	51 x 105	0,08	127	96	90	6,8	2,8	ATX102X350BC1	ATUX102X350BC1
1500		CC	51 x 105	0,08	85	64	62	8,0	3,8	ATX152X350CC1	ATUX152X350CC1
2200		DC	63 x 105	0,08	58	43	43	10,8	5,2	ATX222X350DC1	ATUX222X350DC1
3300		DF	76 x 106	0,08	39	29	30	15,1	7,2	ATX332X350DF1	ATUX332X350DF1
4700		DF	76 x 147	0,08	27	20	23	18,1	8,6	ATX472X350DF1	ATUX472X350DF1
6800		DJ	76 x 217	0,08	19	14	21	21,6	10,3	ATX682X350DJ1	ATUX682X350DJ1
330		AC	35 x 105	0,08	386	290	272	2,7	1,3	ATX331X350AC1	ATUX331X350AC1

AKS SERIES

ALUMINIUM ELECTROLYTIC CAPACITORS FOR PRINTED WIRING BOARD

Series	Capacitance range	Voltage range	Temperature range	Case $\Phi \times H$	Applications
AKS	100 - 47000	40 - 450	-40°C , +85°C	30 x40 40 x 100	Solder pin mounting Industrial applications

MECHANICAL OUTLINES:

CASE: cylindrical aluminium made
 TERMINALS: to be soldered, for printed wiring board
 SEALING: hermetic by beading on a Rubber Bakelite covers
 PRESSURE RELEASE VENT: directly on to the aluminium case
 SLEEVE: self-extinguishing thermoshrinkable sleeve
 MOUNTING: vertical, by soldering to printed circuit board.
 SIZE: see enclosed drawings

SPECIFICATIONS	TEMPERATURE RANGE	CAPACITANCE
CECC 30301-805 IEC 384-4 ("long life grade") DIN 40010 DIN 41240 / DIN 41238	Operating: -40 °C/ +85 °C Climatic Category (IEC 68): 40/85/56	Tolerance shall be within the following limits: -20% + 20% (standard tolerance) or -10% +30% (available on request)

LEAKAGE CURRENT:

After the rated voltage has been applied to the capacitor for 5 minutes the leakage current must be:

Maximum limit	at 25 °C	$I_f \leq 0,004 * C * V$
Operating limit	at 25 °C:	$I_f \leq 0,002 * C * V$

where I_f = leakage current (μA)

C= capacitance (μF)

V= rated voltage (V)

IMPORTANT

When using high-capacitance and high-voltage electrolytic capacitors it is important to remember that the inner part (the rolled section) is not insulated from can: between the negative pole and the aluminium can there is a variable and not defined resistance essentially due to the electrolyte used in capacitor manufacture.

SURGE VOLTAGE

Working Voltage	25	40	50	63	100	160	200	250	400	420	450
Surge Voltage	29	46	58	73	115	185	230	290	440	460	490

RIPPLE CURRENT:

The allowable values of ripple current in amperes, are related to the temperature and frequency by the formula:

$$I_r = K_t * K_f * I_{r85}$$

Where I_{r85} is the limit given by tables, referred to a temperature of 85 °C and to a frequency of 100 Hz and K_t or K_f are values here below tabulated:

°C	40	50	65	75	85
K_t	2.3	1.9	1.7	1.4	1.0

V_N	Hz	50	100	300	400	500	>1KHz
$V \leq 50$	K_f	0.90	1.00	1.14	1.18	1.20	1.25
$50 < V \leq 100$		0.88	1.00	1.20	1.25	1.35	1.40
$V > 100$		0.88	1.00	1.20	1.25	1.35	1.40

CAPACITORS DIMENSIONS AND DRILLING PLAN OF PRINTED WIRING BOARD

D= 30 / 35 mm.

D= 40 mm.

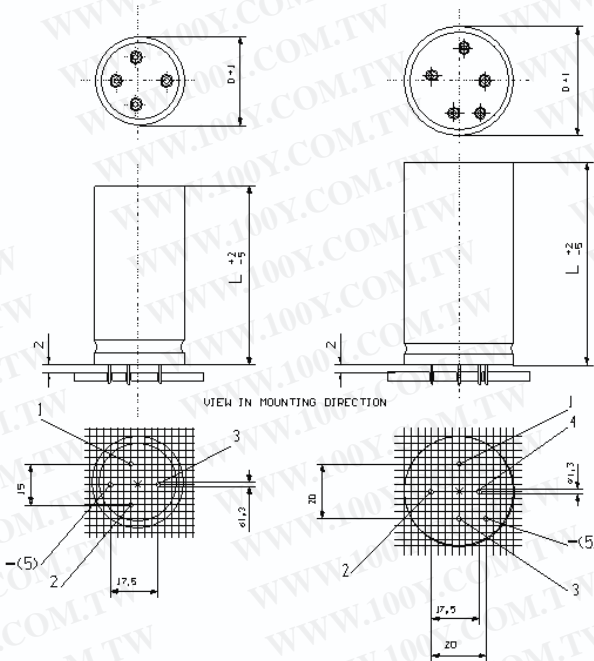

CASE	Φ X L	CASE	Φ X L	CASE	Φ X L	CASE	Φ X L
MB	30 x 40	NC	35 x 50	PB	40 x 40	PE	40 x 75
NB	35 x 40	NE	35 x 75	PC	40 x 50	PG	40 x 100

- Positive pole marked with « 1 »
- The terminals marked with "2", "3", "4» are to be considered only as mechanical connections and must be soldered to insulated pads.

EXPECTED LIFE AS A FUNCTION OF TEMPERATURE AND RIPPLE CURRENT

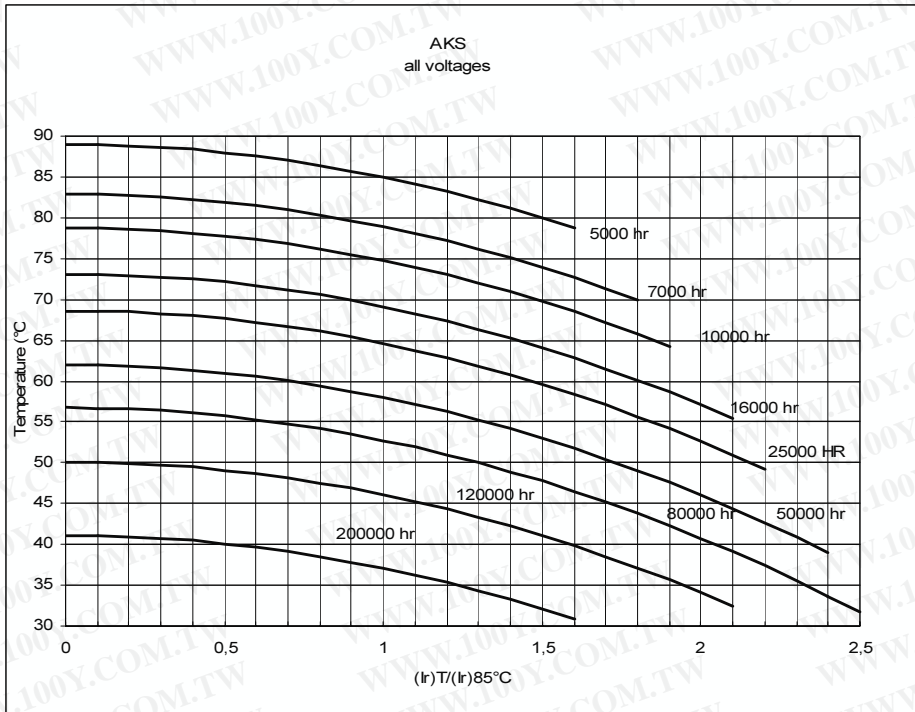

Expected life criteria: see introduction

CAP (μ F)	Rated Voltage (Vn)	Case Code	Φ x h (mm)	TG δ 100Hz	ESR max 100Hz (mOhm)	ESR typ 100Hz (mOhm)	Z max 10KHz (mOhm)	I ripple 55°C 100Hz (A)	I ripple 85°C 100Hz (A)	CATALOGUE NUMBER
6800	40	MB	30 x 40	0,18	32	24	30	11,1	5,9	AKS682M040MB1
10000		NB	35 x 40	0,22	26	20	26	13,2	7,0	AKS103M040NB1
15000		NC	35 x 50	0,34	27	20	26	14,1	7,4	AKS153M040NC1
22000		PC	40 x 50	0,40	22	16	21	17,2	9,0	AKS223M040PC1
33000		PE	40 x 75	0,46	17	12	16	22,4	11,8	AKS333M040PE1
47000		PG	40 x 100	0,55	14	10	14	27,8	14,6	AKS473M040PG1

CAP (μ F)	Rated Voltage (Vn)	Case Code	Φ x h (mm)	TG δ 100Hz	ESR max 100Hz (mOhm)	ESR typ 100Hz (mOhm)	Z max 10KHz (mOhm)	I ripple 55°C 100Hz (A)	I ripple 85°C 100Hz (A)	CATALOGUE NUMBER
4700	63	MB	30 x 40	0,24	61	46	58	8,0	4,2	AKS472M063MB1
6800		NB	35 x 40	0,24	42	32	40	10,5	5,5	AKS682M063NB1
10000		NC	35 x 50	0,26	31	23	30	13,1	6,9	AKS103M063NC1
10000		PC	40 x 50	0,24	29	21	27	14,9	7,9	AKS103M063PC1
15000		PE	40 x 75	0,29	23	17	22	18,9	10,0	AKS153M063PE1
22000		PG	40 x 100	0,32	17	13	25	25,0	13,1	AKS223M063PG1

CAP (μ F)	Rated Voltage (Vn)	Case Code	Φ x h (mm)	TG δ 100Hz	ESR max 100Hz (mOhm)	ESR typ 100Hz (mOhm)	Z max 10KHz (mOhm)	I ripple 55°C 100Hz (A)	I ripple 85°C 100Hz (A)	CATALOGUE NUMBER
1500	100	MB	30 x 40	0,09	72	54	58	7,4	3,9	AKS152M100MB1
2200		NB	35 x 40	0,11	60	45	47	8,9	4,7	AKS222M100NB1
3300		NC	35 x 50	0,11	40	30	31	11,9	6,3	AKS332M100NC1
4700		PC	40 x 50	0,13	33	25	28	13,7	7,2	AKS472M100PC1
6800		PE	40 x 75	0,13	23	17	19	18,9	10,0	AKS682M100PE1
10000		PG	40 x 100	0,13	16	12	13	26,1	13,7	AKS103M100PG1

CAP (μ F)	Rated Voltage (Vn)	Case Code	Φ x h (mm)	TG δ 100Hz	ESR max 100Hz (mOhm)	ESR typ 100Hz (mOhm)	Z max 10KHz (mOhm)	I ripple 55°C 100Hz (A)	I ripple 85°C 100Hz (A)	CATALOGUE NUMBER
330	200	MB	30 x 40	0,09	326	244	252	3,6	1,9	AKS331M200MB1
470		NB	35 x 40	0,09	229	172	176	4,7	2,5	AKS471M200NB1
680		NC	35 x 50	0,09	158	119	122	6,2	3,3	AKS681M200NC1
1000		PC	40 x 50	0,09	107	81	82	8,1	4,3	AKS102M200PC1
1500		PE	40 x 75	0,09	72	54	55	11,4	6,0	AKS152M200PE1
2200		PG	40 x 100	0,09	49	37	38	15,7	8,3	AKS222M200PG1

CAP (μF)	Rated Voltage (Vn)	Case Code	Φ x h (mm)	TG δ 100Hz	ESR max 100Hz (mOhm)	ESR typ 100Hz (mOhm)	Z max 10Khz (mOhm)	I ripple 55°C 100Hz (A)	I ripple 85°C 100Hz (A)	CATALOGUE NUMBER
220	250	MB	30 x 40	0,09	489	366	406	3,0	1,6	AKS221M250MB1
330		NB	35 x 40	0,09	326	244	270	4,0	2,1	AKS331M250NB1
470		NC	35 x 50	0,09	229	172	190	5,2	2,7	AKS471M250NC1
680		PC	40 x 50	0,09	158	119	131	6,7	3,5	AKS681M250PC1
1000		PE	40 x 75	0,09	107	81	89	9,3	4,9	AKS102M250PE1
1500		PG	40 x 100	0,09	72	54	59	13,0	6,8	AKS152M250PG1

CAP (μF)	Rated Voltage (Vn)	Case Code	Φ x h (mm)	TG δ 100Hz	ESR max 100Hz (mOhm)	ESR typ 100Hz (mOhm)	Z max 10Khz (mOhm)	I ripple 55°C 100Hz (A)	I ripple 85°C 100Hz (A)	CATALOGUE NUMBER
150	385	MB	30 x 40	0,09	717	537	587	2,5	1,3	AKS151M385MB1
220		NB	35 x 40	0,09	489	366	405	3,2	1,7	AKS221M385NB1
330		NC	35 x 50	0,09	326	244	270	4,3	2,3	AKS331M385NC1
470		PB	40x 40	0,09	229	172	190	5,6	2,8	AKS471M385PB1
680		PC	40 x 50	0,09	158	119	130	8,6	4,5	AKS681M385PC1
1000		NE	40 x 75	0,09	107	81	130	9,3	4,9	AKS102M385NE1
1000		PE	40 x 75	0,09	107	81	89	10,6	5,6	AKS102M385PE1
1000		PG	40 x 100	0,09	107	81	89	11,0	5,8	AKS102M385PG1
1500		PG	40 x 100	0,09	72	54	66	12,4	6,5	AKS152M385PG1

CAP (μF)	Rated Voltage (Vn)	Case Code	Φ x h (mm)	TG δ 100Hz	ESR max 100Hz (mOhm)	ESR typ 100Hz (mOhm)	Z max 10Khz (mOhm)	I ripple 55°C 100Hz (A)	I ripple 85°C 100Hz (A)	CATALOGUE NUMBER
150	400	MB	30 x 40	0,09	717	537	587	2,5	1,3	AKS151M400MB1
220		NB	35 x 40	0,09	489	366	405	3,2	1,7	AKS221M400NB1
330		NC	35 x 50	0,09	326	244	270	4,3	2,3	AKS331M400NC1
470		PB	40x 40	0,09	229	172	190	5,6	2,8	AKS471M400PB1
680		PC	40 x 50	0,09	158	119	130	8,6	4,5	AKS681M400PC1
1000		NE	40 x 75	0,09	107	81	130	9,3	4,9	AKS102M400NE1
1000		PE	40 x 75	0,09	107	81	89	10,6	5,6	AKS102M400PE1
1000		PG	40 x 100	0,09	107	81	89	11,0	5,8	AKS102M400PG1
1500		PG	40 x 100	0,09	72	54	66	12,4	6,5	AKS152M400PG1

CAP (μ F)	Rated Voltage (Vn)	Case Code	Φ x h (mm)	TG δ 100Hz	ESR max 100Hz (mOhm)	ESR typ 100Hz (mOhm)	Z max 10Khz (mOhm)	I ripple 55°C 100Hz (A)	I ripple 85°C 100Hz (A)	CATALOGUE NUMBER
150	420	MB	30 x 40	0,09	717	537	587	2,5	1,3	AKS151M420MB1
220		NB	35x 40	0,09	489	366	405	3,2	1,7	AKS221M420NB1
330		NC	35 x 50	0,09	326	244	270	4,3	2,3	AKS331M420NC1
680		PC	40 x 50	0,09	158	119	118	7,4	3,9	AKS681M420PC1
1000		NE	35 x 75	0,09	107	81	130	8,2	4,3	AKS102M420NE1
1000		PE	40 x 75	0,09	107	81	130	8,9	4,7	AKS102M420PE1
1000		PG	40 x 100	0,09	107	81	89	10,6	5,6	AKS102M420PG1
1500		PG	40 x 100	0,09	72	54	66	12,4	6,5	AKS152M420PG1

CAP (μ F)	Rated Voltage (Vn)	Case Code	Φ x h (mm)	TG δ 100Hz	ESR max 100Hz (mOhm)	ESR typ 100Hz (mOhm)	Z max 10Khz (mOhm)	I ripple 55°C 100Hz (A)	I ripple 85°C 100Hz (A)	CATALOGUE NUMBER
100	450	MB	30 x 40	0,10	1194	896	869	1,9	1,0	AKS101M450MB1
150		NB	35 x 40	0,10	796	597	579	2,6	1,3	AKS151M450NB1
220		NC	35 x 50	0,10	543	407	394	3,4	1,8	AKS221M450NC1
330		NC	35 x 50	0,10	362	271	263	4,1	2,2	AKS331M450NC1
330		PC	40 x 50	0,10	362	271	263	4,5	2,3	AKS331M450PC1
470		NC	35 x 50	0,10	254	191	185	4,9	2,6	AKS471M450NC1
470		PC	40 x 50	0,10	254	191	185	5,3	2,8	AKS471M450PC1
680		NE	35 x 75	0,10	176	132	139	6,5	3,4	AKS681M450NE1
680		PE	40 x 75	0,10	176	132	127	7,3	3,8	AKS681M450PE1
1000		PE	40 x 75	0,10	119	90	108	8,2	4,3	AKS102M450PE1
1000		PG	40 x 100	0,10	119	90	94	9,7	5,1	AKS102M450PG1
1500		PG	40 x 100	0,10	80	60	80	11,2	5,8	AKS152M450PG1

ACC - ACS SERIES

ALUMINIUM ELECTROLYTIC CAPACITORS FOR PRINTED WIRING BOARD

Series	Capacitance range	Voltage range	Temperature range	Case $\Phi \times H$	Applications
ACC ACS	150 - 33000	25 - 500	-40°C , +85°C	30 x 40 45 x 100	Snap-in type, 2-4 pins configuration Solder pin mounting Industrial applications

MECHANICAL OUTLINES

CASE: cylindrical aluminium made

TERMINALS: to be soldered, for printed wiring board (type SNAP-IN)

SEALING: hermetic by beading on a Rubber-Bakelite cover

PRESSURE RELEASE VENT: directly on to the aluminium case

SLEEVE: self-extinguishing thermoshrinkable sleeve

MOUNTING: vertical, by soldering to printed circuit board.

SIZE: see enclosed drawings

SPECIFICATIONS	TEMPERATURE RANGE	CAPACITANCE
CECC 30300 IEC 384-4 ("long life grade") MIL C62D DIN 41240 / DIN 45910	Operating: -40 °C/ +85 °C Climatic Category : 40/85/56	Tolerance shall be within the following limits: -20% + 20% (standard tolerance) or -10% +30% (available on request)

LEAKAGE CURRENT:

After the rated voltage has been applied to the capacitor for 5 minutes the leakage current must be:

Maximum limit	at 25 °C	$I_f \leq 0,004 * C * V$
Operating limit	at 25 °C:	$I_f \leq 0,002 * C * V$

where I_f = leakage current (μA)

C= capacitance (μF)

V= rated voltage (V)

IMPORTANT

When using high-capacitance and high-voltage electrolytic capacitors it is important to remember that the inner part (the rolled section) is not insulated from can: between the negative pole and the aluminium can there is a variable and not defined resistance essentially due to the electrolyte used in capacitor manufacture.

SURGE VOLTAGE

Working Voltage	25	40	63	100	160	200	250	350	385	400	420	450	500
Surge Voltage	29	46	73	115	185	230	290	385	415	440	460	490	525

RIPPLE CURRENT

The allowable values of ripple current in amperes, are related to the temperature and frequency by the formula:

$$I_r = K_t * K_f * I_{r85}$$

where I_{r85} is the limit given by tables, referred to a temperature of 85 °C and to a frequency of 100 Hz and K_t or K_f are values here below tabulated:

°C	40	50	65	75	85
K_t	2.3	1.9	1.7	1.4	1.0

V_n	HZ	50	100	300	400	500	>1KHZ
$V \leq 50$	K_f	0.90	1.00	1.14	1.18	1.20	1.25
$50 < V \leq 100$		0.88	1.00	1.20	1.25	1.35	1.40
$V > 100$		0.88	1.00	1.20	1.25	1.35	1.40

CAPACITORS DIMENSIONS AND DRILLING PLAN OF PRINTED WIRING BOARD

ACC SERIES

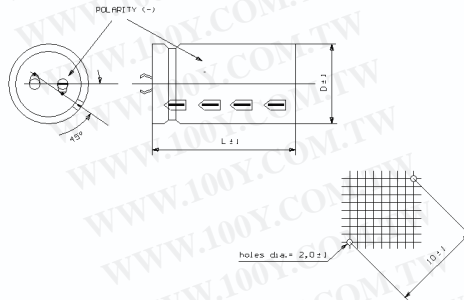

ACC SERIES (D = 35 / 40 / 45 mm)

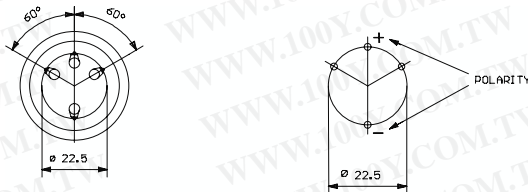

CASE CODE	$\Phi \times l$ (mm)	CASE CODE	$\Phi \times l$ (mm)	CASE CODE	$\Phi \times l$ (mm)	CASE CODE	$\Phi \times l$ (mm)
MB	30 x 40	NN	35 x 60	PN	40 x 60	QE	45 x 75
MC	30 x 50	NE	35 x 75	PG	40 x 100	QG	45 x 100
NB	35 x 40	PB	40 x 40	QC	45 x 50		
NC	35 x 50	PC	40 x 50	QN	45 x 60		

The unconnected pins serve as mountings and must be soldered to insulated pads

EXPECTED LIFE AS A FUNCTION OF TEMPERATURE AND RIPPLE CURRENT

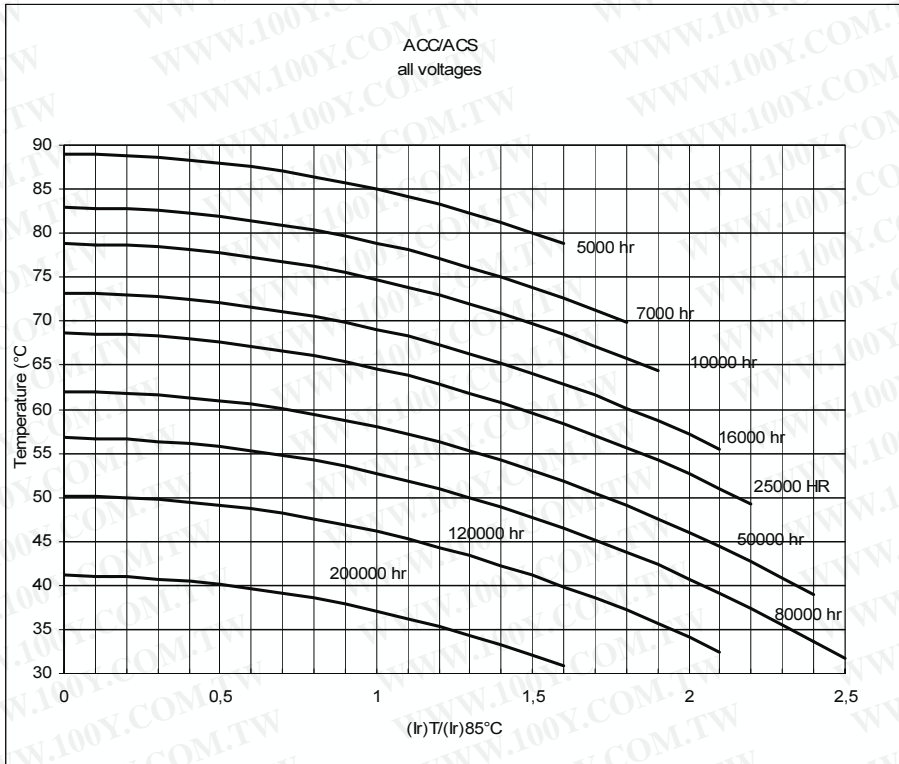

Expected life criteria: see introduction

CAP (μ F)	Rated Voltage (Vn)	Case Code	Φ x h (mm)	TG δ 100Hz	ESR max 100Hz	ESR typ 100Hz	Z max 10Khz	I ripple 55°C 100Hz	I ripple 85°C 100Hz	CATALOGUE NUMBER	
					(mOhm)	(mOhm)	(mOhm)	(A)	(A)	2 mounting pins	4 mounting pins
10000	25	MB	30 x 40	0,28	36	27	29	10,7	5,6	ACC103M025MB1	
15000		MC	30 x 50	0,32	27	20	22	13,5	7,1	ACC153M025MC1	
15000		NB	35 x 40	0,38	32	24	26	13,4	7,1	ACC153M025NB1	ACS153M025NB1
22000		NC	35 x 50	0,48	28	21	19	14,5	7,6	ACC223M025NC1	ACS223M025NC1
33000		PC	40 x 50	0,60	23	17	18	17,2	9,0	ACC333M025PC1	ACS333M025PC1

CAP (μ F)	Rated Voltage (Vn)	Case Code	Φ x h (mm)	TG δ 100Hz	ESR max 100Hz	ESR typ 100Hz	Z max 10Khz	I ripple 55°C 100Hz	I ripple 85°C 100Hz	CATALOGUE NUMBER	
					(mOhm)	(mOhm)	(mOhm)	(A)	(A)	2 mounting pins	4 mounting pins
6800	40	MB	30 x 40	0,30	56	42	40	8,4	4,4	ACC682M040MB1	
10000		MC	30 x 50	0,32	41	31	28	11	5,8	ACC103M040MC1	
10000		NB	35 x 40	0,36	46	34	32	11,3	6	ACC103M040NB1	ACS103M040NB1
15000		NC	35 x 50	0,36	31	23	21	13,9	7,3	ACC153M040NC1	ACS153M040NC1
22000		PC	40 x 50	0,48	28	21	19	15,7	8,3	ACC223M040PC1	ACS223M040PC1

CAP (μ F)	Rated Voltage (Vn)	Case Code	Φ x h (mm)	TG δ 100Hz	ESR max 100Hz	ESR typ 100Hz	Z max 10Khz	I ripple 55°C 100Hz	I ripple 85°C 100Hz	CATALOGUE NUMBER	
					(mOhm)	(mOhm)	(mOhm)	(A)	(A)	2 mounting pins	4 mounting pins
4700	63	MB	30 x 40	0,21	57	43	46	8,5	4,5	ACC472M063MB1	
6800		MC	30 x 50	0,21	39	30	32	11,2	5,9	ACC682M063MC1	
6800		NB	35 x 40	0,24	45	34	37	11,4	6	ACC682M063NB1	ACS682M063NB1
10000		NC	35 x 50	0,24	31	23	25	13,9	7,3	ACC103M063NC1	ACS103M063NC1
12000		PC	40 x 50	0,29	31	23	25	15	7,9	ACC123M063PC1	ACS123M063PC1
15000		PE	40 x 75	0,29	25	18	21	23,2	12,2		ACS153M063PE1
22000		PG	40 x 100	0,29	17	13	21	26	13,8		ACS223M063PG1

CAP (μ F)	Rated Voltage (Vn)	Case Code	Φ x h (mm)	TG δ 100Hz	ESR	ESR	Z	I ripple	I ripple	CATALOGUE NUMBER	
					max 100Hz (mOhm)	typ 100Hz (mOhm)	max 10Khz (mOhm)	55°C 100Hz (A)	85°C 100Hz (A)	2 mounting pins	4 mounting pins
1500	100	MB	30 x 40	0,09	76	57	66	7,1	3,7	ACC152M100MB1	
2200		MC	30 x 50	0,10	58	43	57	8,4	4,4	ACC222M100MC1	
2200		NB	35 x 40	0,11	64	48	57	9,2	4,8	ACC222M100NB1	ACS222M100NB1
3300		NC	35 x 50	0,12	46	35	38	11,3	5,9	ACC332M100NC1	ACS332M100NC1
4700		NC	35 x 50	0,12	33	24	26	13,4	7,1	ACC472M100NC1	ACS472M100NC1
5600		NC	35 x 50	0,12	27	20	32	14,7	7,7	ACC562M100NC1	ACS562M100NC1
6800		PE	40 x 75	0,12	22	17	26	24,2	12,7		ACS682M100PE1
10000		PG	40 x 100	0,12	15	11	26	25,8	13,8		ACS103M100PG1

CAP (μ F)	Rated Voltage (Vn)	Case Code	Φ x h (mm)	TG δ 100Hz	ESR	ESR	Z	I ripple	I ripple	CATALOGUE NUMBER	
					max 100Hz (mOhm)	typ 100Hz (mOhm)	max 10Khz (mOhm)	55°C 100Hz (A)	85°C 100Hz (A)	2 mounting pins	4 mounting pins
470	200	MB	30 x 40	0,08	217	163	176	4,7	2,5	ACC471M200MB1	
680		MB	30 x 40	0,08	150	112	122	5,7	3	ACC681M200MB1	
1000		MC	30 x 50	0,08	102	76	82	7,6	4	ACC102M200MC1	
1000		NB	35 x 40	0,08	102	76	82	8,3	4,4	ACC102M200NB1	ACS102M200NB1
1200		NB	35 x 40	0,08	85	64	80	9,1	4,8	ACC122M200NB1	ACS122M200NB1
1500		NC	35 x 50	0,08	68	51	56	10,1	5,3	ACC152M200NC1	ACS152M200NC1
1800		NC	35 x 50	0,08	57	42	56	11,1	5,8	ACC182M200NC1	ACS182M200NC1
2200		PG	40 x 100	0,08	46	35	38	14,8	7,8	ACC222M200PG1	ACS222M200PG1
3300		PG	40 x 100	0,08	31	23	38	22,5	11,8		ACS332M200PG1
2200		QC	45 x 50	0,08	46	35	38	14,2	7,5		ACS222M200QC1
3300		QE	45 x 75	0,08	31	23	38	20,7	10,9		ACS332M200QE1
4700		QG	45 x 100	0,08	22	16	38	28,6	15,1		ACS472M200QG1

CAP (μ F)	Rated Voltage (Vn)	Case Code	Φ x h (mm)	TG δ 100Hz	ESR	ESR	Z	I ripple	I ripple	CATALOGUE NUMBER	
					max 100Hz (mOhm)	typ 100Hz (mOhm)	max 10Khz (mOhm)	55°C 100Hz (A)	85°C 100Hz (A)	2 mounting pins	4 mounting pins
470	250	MB	30 x 40	0,08	217	163	190	4,7	2,5	ACC471M250MB1	
680		MC	30 x 50	0,08	150	112	131	6,3	3,3	ACC681M250MC1	
680		NB	35 x 40	0,08	150	112	131	6,8	3,6	ACC681M250NB1	ACS681M250NB1
1000		NB	35 x 40	0,08	102	76	120	8,3	4,4	ACC102M250NB1	ACS102M250NB1
1000		NC	35 x 50	0,08	102	76	89	8,3	4,4	ACC102M250NC1	ACS102M250NC1
2200		NE	35 x 75	0,08	46	35	89	14,7	7,7	ACC222M250NE1	ACS222M250NE1
1500		PC	40 x 50	0,08	68	51	59	11	5,8	ACC152M250PC1	ACS152M250PC1
2200		PG	40 x 100	0,08	46	35	38	18,4	9,7		ACS222M250PG1

CAP (μ F)	Rated Voltage (Vn)	Case Code	Φ x h (mm)	TG δ 100Hz	ESR	ESR	Z	I ripple	I ripple	CATALOGUE NUMBER	
					max 100Hz (mOhm)	typ 100Hz (mOhm)	max 10Khz (mOhm)	55°C 100Hz (A)	85°C 100Hz (A)	2 mounting pins	4 mounting pins
220	385	MB	30 x 40	0,08	463	347	406	3,2	1,7	ACC221M400MB1	
330		MB	30 x 40	0,08	309	232	270	4	2,1	ACC331M400MB1	
330		MC	30 x 50	0,08	309	232	270	4,4	2,3	ACC331M400MC1	
470		MC	30 x 50	0,08	217	163	190	5,2	2,7	ACC471M400MC1	
470		NB	35 x 40	0,08	217	163	190	5,7	2,8	ACC471M400NB1	ACS471M400NB1
470		NC	35 x 50	0,08	217	163	170	5,7	3	ACC471M400NC1	ACS471M400NC1
560		NC	35 x 50	0,08	182	136	143	6,2	3,3	ACC561M400NC1	ACS561M400NC1
680		NC	35 x 50	0,08	150	112	120	6,8	3,6	ACC681M400NC1	ACS681M400NC1
1000		NN	35 x 60	0,08	102	76	118	9	4,7	ACC102M400NN1	ACS102M400NN1
1200		NE	35 x 75	0,08	85	64	98	10,8	5,7	ACC122M400NE1	ACS122M400NE1
470		PB	40 x 40	0,08	217	163	82	5,6	3,3	ACC471M400PB1	ACS471M400PB1
680		PC	40 x 50	0,08	150	112	63	7,4	3,9	ACC681M400PC1	ACS681M400PC1
1000		PE	40 x 75	0,08	100	75	63	10,6	5,6		ACS102M400PE1
1500		PG	40 x 100	0,08	90	68	63	15,2	8		ACS152M400PG1
1000		QC	45 x 50	0,08	85	64	63	9,6	5		ACS102M400QC1
1500		QE	45 x 75	0,08	85	64	63	13,9	7,3		ACS152M400QE1
2200		QG	45 x 100	0,08	85	64	63	19,6	10,3		ACS222M400QG1

CAP (μ F)	Rated Voltage (Vn)	Case Code	Φ x h (mm)	TG δ 100Hz	ESR	ESR	Z	I ripple	I ripple	CATALOGUE NUMBER	
					max 100Hz (mOhm)	typ 100Hz (mOhm)	max 10Khz (mOhm)	55°C 100Hz (A)	85°C 100Hz (A)	2 mounting pins	4 mounting pins
220	400	MB	30 x 40	0,08	463	347	406	3,2	1,7	ACC221M400MB1	
330		MB	30 x 40	0,08	309	232	270	4	2,1	ACC331M400MB1	
330		MC	30 x 50	0,08	309	232	270	4,4	2,3	ACC331M400MC1	
470		MC	30 x 50	0,08	217	163	190	5,2	2,7	ACC471M400MC1	
470		NB	35 x 40	0,08	217	163	190	5,7	2,8	ACC471M400NB1	ACS471M400NB1
470		NC	35 x 50	0,08	217	163	170	5,7	3	ACC471M400NC1	ACS471M400NC1
560		NC	35 x 50	0,08	182	136	143	6,2	3,3	ACC561M400NC1	ACS561M400NC1
680		NC	35 x 50	0,08	150	112	120	6,8	3,6	ACC681M400NC1	ACS681M400NC1
1000		NN	35 x 60	0,08	136	76	118	9	4,7	ACC102M400NN1	ACS102M400NN1
1200		NE	35 x 75	0,08	85	64	98	10,8	5,7	ACC122M400NE1	ACS122M400NE1
470		PB	40 x 40	0,08	217	163	82	5,6	3,3	ACC471M400PB1	ACS471M400PB1
680		PC	40 x 50	0,08	150	112	63	7,4	3,9	ACC681M400PC1	ACS681M400PC1
1000		PE	40 x 75	0,08	100	75	63	10,6	5,6		ACS102M400PE1
1500		PG	40 x 100	0,08	90	68	63	15,2	8		ACS152M400PG1
1000		QC	45 x 50	0,08	85	64	63	9,6	5		ACS102M400QC1
1500		QE	45 x 75	0,08	85	64	63	13,9	7,3		ACS152M400QE1
2200		QG	45 x 100	0,08	85	64	63	19,6	10,3		ACS222M400QG1

CAP (μ F)	Rated Voltage (Vn)	Case Code	Φ x h (mm)	TG δ 100Hz	ESR	ESR	Z	I ripple	I ripple	CATALOGUE NUMBER	
					max 100Hz (mOhm)	typ 100Hz (mOhm)	max 10Khz (mOhm)	55°C 100Hz (A)	85°C 100Hz (A)	2 mounting pins	4 mounting pins
150	420	MB	30 x 40	0,08	679	510	190	1,8	1,8	ACC151M420MB1	
220		NB	35 x 40	0,08	463	347	190	3,2	1,7	ACC221M420NB1	
330		MC	30 x 50	0,08	309	232	190	4,4	2,3	ACC331M420MC1	
470		NC	35 x 50	0,08	217	163	170	5,7	3	ACC471M420NC1	ACS471M420NC1
1000		NE	35 x 75	0,08	102	76	130	9	4,7	ACC102M420NE1	ACS102M420NE1
680		PC	40 x 50	0,08	150	112	190	7,4	3,9	ACC681M420PC1	ACS681M420PC1
1000		PE	40 x 75	0,08	102	76	130	10,6	5,6		ACS102M420PE1
1000		PG	40 x 100	0,08	102	76	89	10,8	5,8		ACS102M420PG1
1500		PG	40 x 100	0,08	68	51	89	15,2	8		ACS152M420PG1

CAP (μ F)	Rated Voltage (Vn)	Case Code	Φ x h (mm)	TG δ 100Hz	ESR	ESR	Z	I ripple	I ripple	CATALOGUE NUMBER	
					max 100Hz (mOhm)	typ 100Hz (mOhm)	max 10Khz (mOhm)	55°C 100Hz (A)	85°C 100Hz (A)	2 mounting pins	4 mounting pins
150	450	MB	30 x 40	0,08	679	510	631	2,4	1,3	ACC151M450MB1	
220		MB	30 x 40	0,08	463	347	430	3	1,6	ACC221M450MB1	
330		MC	30 x 50	0,08	309	232	286	4	2,1	ACC331M450MC1	
330		NB	35 x 40	0,08	309	232	286	4,3	2,3	ACC331M450NB1	ACS331M450NB1
470		NC	35 x 50	0,08	217	163	185	6,3	3,3	ACC471M450NC1	ACS471M450NC1
680		NN	35 x 50	0,08	150	112	155	7,4	3,9	ACC681M450NN1	ACS681M450NN1
820		NE	35 x 75	0,08	124	93	128	8,5	4,5	ACC821M450NE1	ACS821M450NE1
680		PC	40 x 50	0,08	150	112	128	7	3,7	ACC681M450PC1	ACS681M450PC1
1000		PE	40 x 75	0,08	102	76	128	9,7	5,1	ACC102M450PE1	ACS102M450PE1
1500		PG	40 x 100	0,08	68	51	128	13,8	7,3		ACS152M450PG1
820		QC	45 x 50	0,08	124	93	128	7,9	4,2		ACS821M450QC1
1200		QE	45 x 75	0,08	85	64	128	11,4	6		ACS122M450QE1
1800		QG	45 x 100	0,08	57	42	128	16,2	8,5		ACS182M450QG1
2200		QG	45 x 100	0,08	46	35	128	18,2	10,5		ACS222M450QG1

CAP (μ F)	Rated Voltage (Vn)	Case Code	Φ x h (mm)	TG δ 100Hz	ESR	ESR	Z	I ripple	I ripple	CATALOGUE NUMBER	
					max 100Hz (mOhm)	typ 100Hz (mOhm)	max 10Khz (mOhm)	55°C 100Hz (A)	85°C 100Hz (A)	2 mounting pins	4 mounting pins
150	500	MB	30 x 40	0,15	1274	955	790	1,5	0,8	ACC151M500MB1	
220		MC	30 x 50	0,15	869	651	538	2	1,1	ACC221M500MC1	
220		NB	35 x 40	0,15	869	651	538	2	1,1	ACC221M500NB1	ACS221M500NB1
330		NC	35 x 50	0,15	579	434	359	2,7	1,5	ACC331M500NC1	ACS331M500NC1
470		PC	40 x 50	0,15	407	305	252	3,6	2	ACC471M500PC1	ACS471M500PC1
680		PG	40 x 100	0,15	281	211	192	6,9	3,7		ACS681M500PG1

AZK SERIES

ALUMINIUM ELECTROLYTIC CAPACITORS FOR PRINTED WIRING BOARD

Series	Capacitance range	Voltage range	Temperature range	Case Φ x H	Applications
<u>AZK</u>	100 - 2200	200 - 450	-25°C , +105°C	30 x40 40 x 100	Extended temperature range Low ESR Solder pin mounting Industrial applications

MECHANICAL OUTLINES:

CASE: cylindrical aluminium made

TERMINALS: to be soldered, for printed wiring board

SEALING: hermetic by beading on a Rubber Bakelite covers

PRESSURE RELEASE VENT: directly on to the aluminium case

SLEEVE: self-extinguishing thermoshrinkable sleeve

MOUNTING: vertical, by soldering to printed circuit board.

SIZE: see enclosed drawings

SPECIFICATIONS	TEMPERATURE RANGE	CAPACITANCE
CECC 30301-805 IEC 384-4 ("long life grade") DIN 40010 DIN 41240 / DIN 41238	Operating: -25 °C/ +105 °C Climatic Category (IEC 68): 25/105/56	Tolerance shall be within the following limits: -20% + 20% (standard tolerance) or -10% +30% (available on request)

LEAKAGE CURRENT:

After the rated voltage has been applied to the capacitor for 5 minutes the leakage current must be:

Maximum limit	at 25 °C	$I_f \leq 0,004 * C * V$
Operating limit	at 25 °C:	$I_f \leq 0,002 * C * V$

where I_f = leakage current (μ A)

C = capacitance (μ F)

V = rated voltage (V)

IMPORTANT

When using high-capacitance and high-voltage electrolytic capacitors it is important to remember that the inner part (the rolled section) is not insulated from can: between the negative pole and the aluminium can there is a variable and not defined resistance essentially due to the electrolyte used in capacitor manufacture.

SURGE VOLTAGE

Working Voltage	200	250	400	420	450
Surge Voltage	230	290	440	460	490

EXPECTED LIFE AS A FUNCTION OF TEMPERATURE AND RIPPLE CURRENT

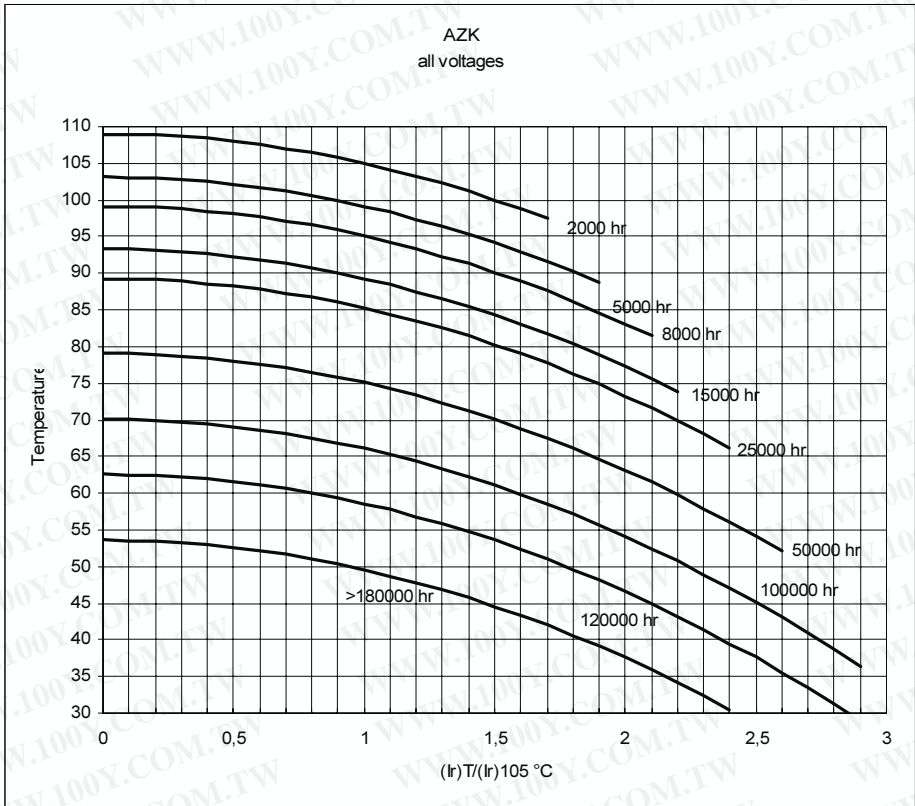

Expected life criteria: see introduction.

CAP [μ F]	Rated Voltage [Vn]	Case Code	Φ x h [mm]	TG δ 100 Hz	ESR max 100Hz (mOhm)	ESR typ 100Hz (mOhm)	Z max 10Khz (mOhm)	I ripple 75°C 100Hz [A.]	I ripple 105°C 100Hz [A.]	CATALOGUE NUMBER
330	200	NB	35 x 40	0,10	362	271	221	3,0	1,4	AZK331M200NB1
470		NC	35 x 50	0,10	254	191	154	4,0	1,9	AZK471M200NC1
680		NC	35 x 50	0,10	176	132	106	5,2	2,5	AZK681M200NC1
1000		PC	40 x 50	0,10	119	90	72	6,8	3,2	AZK102M200PC1
1500		PE	40 x 75	0,10	80	60	48	9,5	4,5	AZK152M200PE1
2200		PG	40 x 100	0,10	54	41	33	13,1	6,2	AZK222M200PG1

CAP [μ F]	Rated Voltage [Vn]	Case Code	Φ x h	TG δ	ESR max 100Hz (mOhm)	ESR typ 100Hz (mOhm)	Z max 10Khz (mOhm)	I ripple 75°C 100Hz [A.]	I ripple 105°C 100Hz [A.]	CATALOGUE NUMBER
220	250	MB	30 x 40	0,10	543	407	355	2,5	1,2	AZK221M250MB1
330		NB	35 x 40	0,10	362	271	237	3,3	1,6	AZK331M250NB1
470		NC	35 x 50	0,10	254	191	166	4,3	2,0	AZK471M250NC1
680		PC	40 x 50	0,10	176	132	115	5,6	2,7	AZK681M250PC1
1000		PE	40 x 75	0,10	119	90	78	7,7	3,7	AZK102M250PE1
1500		PG	40 x 100	0,10	80	60	52	10,8	5,1	AZK152M250PG1

CAP [μ F]	Rated Voltage [Vn]	Case Code	Φ x h	TG δ	ESR max 100Hz (mOhm)	ESR typ 100Hz (mOhm)	Z max 10Khz (mOhm)	I ripple 75°C 100Hz [A.]	I ripple 105°C 100Hz [A.]	CATALOGUE NUMBER
150	385	MB	30 x 40	0,10	796	597	514	2,0	1,0	AZK151M385MB1
220		NB	35 x 40	0,10	543	407	354	2,7	1,3	AZK221M385NB1
330		NC	35 x 50	0,10	362	271	237	3,6	1,7	AZK331M385NC1
470		PC	40 x 50	0,10	254	191	166	4,6	2,2	AZK471M385PC1
680		PE	40 x 76	0,10	176	132	114	6,4	3,0	AZK681M385PE1
1000		PG	40 x 100	0,10	119	90	78	8,8	4,2	AZK102M385PG1

CAP [μ F]	Rated Voltage [Vn]	Case Code	Φ x h	TG δ	ESR max 100Hz (mOhm)	ESR typ 100Hz (mOhm)	Z max 10KHz (mOhm)	I ripple 75°C 100Hz [A.]	I ripple 105°C 100Hz [A.]	CATALOGUE NUMBER
150	400	MB	35 x 40	0,10	796	597	514	2,0	1,0	AZK151M400MB1
220		NB	35 x 40	0,10	543	407	354	2,7	1,3	AZK221M400NB1
330		NC	35 x 50	0,10	362	271	237	3,6	1,7	AZK331M400NC1
470		PC	40 x 50	0,10	254	191	166	4,6	2,2	AZK471M400PC1
1000		NE	35 x 75	0,10	119	90	114	7,2	3,4	AZK102M400NE1
680		PC	40 x 50	0,10	176	132	114	7,7	3,0	AZK681M400PC1
1000		PE	40 x 75	0,10	119	90	114	7,7	3,7	AZK102M400PE1
1000		PG	40 x 100	0,10	119	90	78	8,8	4,2	AZK102M400PG1
1200		PG	40 x 100	0,10	100	75	71	9,2	4,4	AZK122M400PG1
1500		PG	40 x 100	0,10	80	60	57	10,2	4,9	AZK152M400PG1

CAP [μ F]	Rated Voltage [Vn]	Case NB	Φ x h	TG δ	ESR max 100Hz (mOhm)	ESR typ 100Hz (mOhm)	Z max 10KHz (mOhm)	I ripple 75°C 100Hz [A.]	I ripple 105°C 100Hz 1.71734	CATALOGUE NUMBER
150	420	MB	30 x 40	0,10	796	597	514	2,0	1,0	AZK151M420MB1
220		NB	35 x 40	0,10	543	407	354	2,7	1,3	AZK221M420NB1
330		NC	35 x 50	0,10	362	271	237	3,6	1,7	AZK331M420NC1
470		PC	40 x 50	0,10	254	191	166	4,6	2,2	AZK471M420PC1
1000		NE	35 x 75	0,10	119	90	114	6,9	3,3	AZK102M420NE1
1000		PE	40 x 75	0,10	119	90	114	7,4	3,5	AZK102M420PE1
1000		PG	40 x 100	0,10	119	90	78	8,8	4,2	AZK102M420PG1
1200		PG	40 x 100	0,10	100	75	71	9,2	4,4	AZK122M420PG1
1500		PG	40 x 100	0,10	80	60	57	10,3	4,9	AZK152M420PG1

CAP [μ F]	Rated Voltage [Vn]	Case NB	Φ x h	TG δ	ESR max 100Hz (mOhm)	ESR typ 100Hz (mOhm)	Z max 10KHz (mOhm)	I ripple 75°C 100Hz [A.]	I ripple 105°C 100Hz 1.71734	CATALOGUE NUMBER
100	450	MB	30 x 40	0,10	1194	896	760	1,6	0,8	AZK101M450MB1
150		NB	30 x 40	0,10	796	597	507	2,1	1,0	AZK151M450NB1
220		NC	35 x 50	0,10	543	407	345	2,8	1,3	AZK221M450NC1
330		NC	35 x 50	0,10	362	271	230	3,4	1,6	AZK331M450NC1
330		PC	40 x 50	0,10	362	271	230	3,7	1,8	AZK331M450PC1
470		NC	35 x 50	0,10	254	191	162	4,1	2,0	AZK471M450NC1
470		PC	40 x 50	0,10	254	191	162	4,4	2,1	AZK471M450PC1
680		NE	35 x 75	0,10	176	132	122	5,4	2,6	AZK681M450NE1
680		PE	40 x 75	0,10	176	132	111	6,1	2,9	AZK681M450PE1
1000		PE	40 x 75	0,10	119	90	95	6,8	3,2	AZK102M450PE1
1000		PG	40 x 100	0,10	119	90	83	8,0	3,8	AZK102M450PG1
1200		PG	40 x 100	0,10	100	75	70	8,8	4,2	AZK122M450PG1

ATK SERIES

ALUMINIUM ELECTROLYTIC CAPACITORS FOR PRINTED WIRING BOARD LONG LIFE

Series	Capacitance range	Voltage range	Temperature range	Case $\Phi \times H$	Applications
ATK	100 - 2200	160 - 450	-25°C , +105°C	30 x40 40 x 100	Extended temperature range Low ESR Solder pin mounting Industrial applications

MECHANICAL OUTLINES:

CASE: cylindrical aluminium made

TERMINALS: to be soldered, for printed wiring board

SEALING: hermetic by beading on a Rubber Bakelite covers

PRESSURE RELEASE VENT: directly on to the aluminium case

SLEEVE: self-extinguishing thermoshrinkable sleeve

MOUNTING: vertical, by soldering to printed circuit board.

SIZE: see enclosed drawings

SPECIFICATIONS	TEMPERATURE RANGE	CAPACITANCE
CECC 30301-805 IEC 384-4 ("long life grade") DIN 40010 DIN 41240 / DIN 41238	Operating: -25 °C/ +105 °C Climatic Category (IEC 68): 25/105/56	Tolerance shall be within the following limits: -20% + 20% (standard tolerance) or -10% +30% (available on request)

LEAKAGE CURRENT:

After the rated voltage has been applied to the capacitor for 5 minutes the leakage current must be:

Maximum limit	at 25 °C	$I_f \leq 1.3 \cdot \sqrt{C \cdot V}$
Operating limit	at 25 °C:	$I_f \leq 1.0 \cdot \sqrt{C \cdot V}$

where I_f = leakage current (μA)

C= capacitance (μF)

V= rated voltage (V)

IMPORTANT

When using high-capacitance and high-voltage electrolytic capacitors it is important to remember that the inner part (the rolled section) is not insulated from can: between the negative pole and the aluminium can there is a variable and not defined resistance essentially due to the electrolyte used in capacitor manufacture.

SURGE VOLTAGE

Working Voltage	200	250	350	400	420	450
Surge Voltage	230	290	385	440	460	495

RIPPLE CURRENT:

The allowable values of ripple current in amperes, are related to the temperature and frequency by the formula:

$$I_r = K_t * K_f * I_{r105}$$

Where I_{r105} is the limit given by tables, referred to a temperature of 105°C and to a frequency of 100 Hz and K_t or K_f are values here below tabulated:

°C	50	65	75	85	95	105
K_t	2.4	2.4	2.1	1.8	1.3	1.0

V_n	Hz	50	100	300	400	500	>1KHz
V>160		0.88	1.00	1.20	1.25	1.35	1.40

CAPACITORS DIMENSIONS AND DRILLING PLAN OF PRINTED WIRING BOARD

D= 30 / 35 mm.

D= 40 mm.

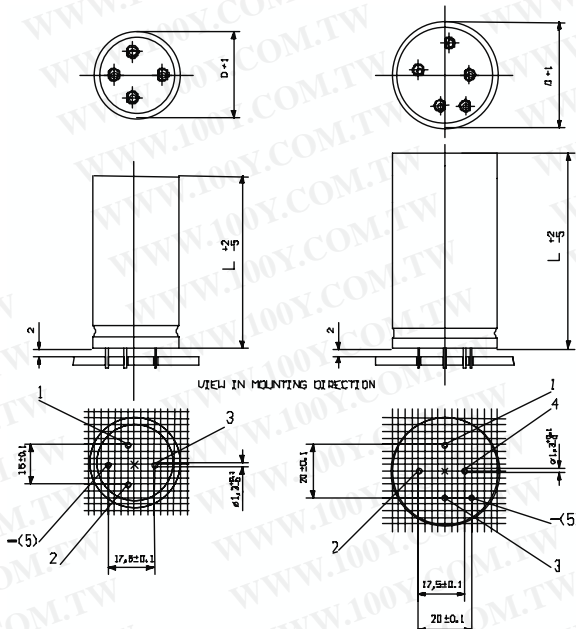

CASE	Φ X L	CASE	Φ X L	CASE	Φ X L	CASE	Φ X L
MB	30 x 40	NC	35 x 50	PB	40 x 40	PE	40 x 75
NB	35 x 40	NE	35 x 75	PC	40 x 50	PG	40 x 100

- positive pole marked with << 1 >>
- The terminals marked with "2", "3", "4" are to be considered only as mechanical connections and must be soldered to insulated pads.

EXPECTED LIFE AS A FUNCTION OF TEMPERATURE AND RIPPLE CURRENT

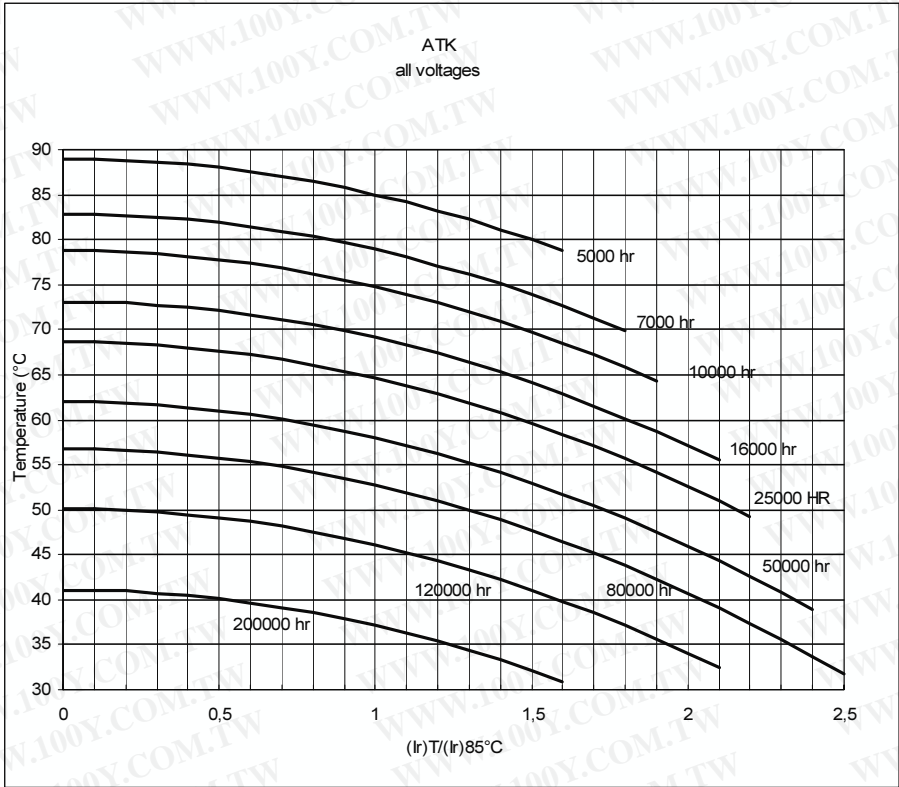

Expected life criteria: see introduction

CAP (μ F)	Rated Voltage (Vn)	Case Code	Φ x h (mm)	TG δ 100Hz	ESR max 100Hz (mOhm)	ESR Typ 100Hz (mOhm)	Z max 10Khz (mOhm)	I ripple 75°C 100Hz (A)	I ripple 105°C 100Hz (A)	CATALOGUE NUMBER
220	200	MB	30 x 40	0,10	543	407	355	2,0	0,9	ATK221M200MB1
330		NB	35 x 40	0,10	362	271	270	2,6	1,3	ATK331M200NB1
470		NC	35 x 50	0,10	254	191	166	3,4	1,6	ATK471M200NC1
680		PC	40 x 50	0,10	176	132	115	4,3	2,0	ATK681M200PC1
1000		PE	40 x 75	0,10	119	90	78	6,2	3,0	ATK102M200PE1
1500		PG	40 x 100	0,10	80	60	52	8,8	4,2	ATK152M200PG1

CAP (μ F)	Rated Voltage (Vn)	Case Code	Φ x h (mm)	TG δ 100Hz	ESR max 100Hz (mOhm)	ESR Typ 100Hz (mOhm)	Z max 10Khz (mOhm)	I ripple 75°C 100Hz (A)	I ripple 105°C 100Hz (A)	CATALOGUE NUMBER
220	250	MB	30 x 40	0,08	434	326	514	2,2	1,1	ATK221M250MB1
220		NB	35 x 40	0,08	434	326	354	2,4	1,2	ATK221M250NB1
330		NC	35 x 50	0,08	290	217	237	3,5	1,7	ATK331M250NC1
680		PC	40 x 50	0,08	141	105	166	4,8	2,3	ATK681M250PC1
1800		PE	40 x 75	0,08	53	40	114	9,3	4,4	ATK182M250PE1
2200		PG	40 x 100	0,08	43	33	78	12,0	5,7	ATK222M250PG1

CAP (μ F)	Rated Voltage (Vn)	Case Code	Φ x h (mm)	TG δ 100Hz	ESR max 100Hz (mOhm)	ESR Typ 100Hz (mOhm)	Z max 10Khz (mOhm)	I ripple 75°C 100Hz (A)	I ripple 105°C 100Hz (A)	CATALOGUE NUMBER
100	400	MB	30 x 40	0,08	0	0	0	1,5	0,7	
150		NB	35 x 40	0,08	637	478	495	2,0	1,0	ATK151M400NB1
220		NC	35 x 50	0,08	434	326	337	2,6	1,3	ATK221M400NC1
330		NC	35 x 50	0,08	290	217	225	3,2	1,5	ATK331M400NC1
330		PC	40 x 50	0,08	290	217	225	3,3	1,6	ATK331M400PC1
470		NC	35 x 50	0,08	203	152	158	3,8	1,8	ATK471M400NC1
470		PC	40 x 50	0,08	203	152	158	4,0	1,9	ATK471M400PC1
680		NE	35 x 75	0,08	141	105	109	5,3	2,5	ATK681M400NE1
680		PE	40 x 75	0,08	141	105	109	5,7	2,7	ATK681M400PE1
1000		PE	40 x 75	0,08	96	72	74	6,9	3,3	ATK102M400PE1
1000		PG	40 x 100	0,08	96	72	74	8,1	3,8	ATK102M400PG1
1500		PG	40 x 100	0,08	64	48	62	11,2	5,6	ATK152M400PG1

CAP (μ F)	Rated Voltage (Vn)	Case Code	Φ x h (mm)	TG δ 100Hz	ESR max 100Hz (mOhm)	ESR Typ 100Hz (mOhm)	Z max 10Khz (mOhm)	I ripple 75°C 100Hz (A)	I ripple 105°C 100Hz (A)	CATALOGUE NUMBER
100	420	MB	30 x 40	0,09	1075	806	0	1,4	0,7	ATK101M420MB1
150		NB	35 x 40	0,09	717	537	760	1,9	0,9	ATK151M420NB1
220		NC	35 x 50	0,09	489	366	507	2,5	1,2	ATK221M420NC1
330		NC	35 x 50	0,09	326	244	345	3,0	1,4	ATK331M420NC1
330		PC	40 x 50	0,09	326	244	230	3,2	1,5	ATK331M420PC1
470		NC	35 x 50	0,09	229	172	230	3,6	1,7	ATK471M420NC1
470		PC	40 x 50	0,09	229	172	162	3,8	1,8	ATK471M420PC1
680		NE	35 x 75	0,09	158	119	162	5,0	2,4	ATK681M420NE1
680		PE	40 x 75	0,09	158	119	122	5,4	2,6	ATK681M420PE1
1000		PE	40 x 75	0,09	107	81	111	6,5	3,1	ATK102M420PE1
1000		PG	40 x 100	0,09	107	81	95	7,6	3,6	ATK102M420PG1
1500		PG	40 x 100	0,10	80	60	83	11,0	5,3	ATK152M420PG1

CAP (μ F)	Rated Voltage (Vn)	Case Code	Φ x h (mm)	TG δ 100Hz	ESR max 100Hz (mOhm)	ESR Typ 100Hz (mOhm)	Z max 10Khz (mOhm)	I ripple 75°C 100Hz (A)	I ripple 105°C 100Hz (A)	CATALOGUE NUMBER
220	450	MB	30 x 40	0,09	489	366	378	1,8	1,0	ATK221M450MB1
330		MC	30 x 50	0,09	326	244	252	2,4	1,3	ATK331M450MC1
330		NB	35 x 40	0,09	326	244	252	2,4	1,3	ATK331M450NB1
470		NC	35 x 50	0,09	229	172	175	3,1	1,7	ATK471M450NC1
470		PB	40 x 40	0,09	229	172	175	3,1	1,7	ATK471M450PB1
560		PC	40 x 50	0,09	103	77	147	3,7	2,0	ATK561M450PC1
680		NE	35 x 75	0,09	158	119	123	4,3	2,4	ATK681M450NE1
820		PE	40 x 75	0,09	131	98	102	5,1	2,8	ATK821M450PE1
1000		PG	40 x 100	0,10	119	90	83	6,5	3,6	ATK102M450PG1
1200		PG	40 x 100	0,10	100	75	69	7,1	4,0	ATK122M450PG1

AZC - AZS SERIES

ALUMINIUM ELECTROLYTIC CAPACITORS FOR PRINTED WIRING BOARD

Series	Capacitance range	Voltage range	Temperature range	Case $\Phi \times H$	Applications
<u>AZC</u> <u>AZS</u>	100 - 4700	200 -450	-25°C , +105°C	30 x 40 45 x 100	Snap-in type, 2-4 pins configuration Extended temperature range Solder pin mounting Industrial applications

MECHANICAL OUTLINES:

CASE: cylindrical, aluminium made

TERMINALS: to be soldered, for printed wiring board (type SNAP-IN)

SEALING: hermetic by beading on a rubber-Bakelite cover

PRESSURE RELEASE VENT: directly on to the aluminium case

SLEEVE: self-extinguishing thermo shrinkable sleeve

MOUNTING: vertical, by soldering to printed circuit board.

SIZE: see enclosed drawings

CLIMATIC CATEGORY (IEC 68): 25/98/56

SPECIFICATIONS	TEMPERATURE RANGE	CAPACITANCE
CECC 30300 IEC 384-4 ("long life grade") MIL C62D DIN 41240 / DIN 45910	Operating: -25 °C +105 °C Climatic Category (IEC 68): 25/105/56	Tolerance shall be within the following limits: -20% + 20% (standard tolerance) or -10% +30% (available on request)

LEAKAGE CURRENT:

After the rated voltage has been applied to the capacitor for 5 minutes the leakage current must be:

Maximum limit	at 25 °C	$I_f \leq 0,004 * C * V$
Operating limit	at 25 °C:	$I_f \leq 0,001 * C * V$

where I_f = leakage current (μA)

C= capacitance (μF)

V= rated voltage (V)

IMPORTANT

When using high-capacitance and high-voltage electrolytic capacitors it is important to remember that the inner part (the rolled section) is not insulated from can: between the negative pole and the aluminium can there is a variable and not defined resistance essentially due to the electrolyte used in capacitor manufacture.

SURGE VOLTAGE

Working Voltage	200	250	315	400	420	450	500
Surge Voltage	230	290	347	440	460	495	525

RIPPLE CURRENT:

The allowable values of ripple current in amperes, are related to the temperature and frequency by the formula:

$$I_r = K_t * K_f * I_{r105}$$

where I_{r105} is the limit given by tables, referred to a temperature of 105 °C and to a frequency of 100 Hz and K_t or K_f are values here below tabulated:

°C	50	65	75	85	95	105
K_t	2.6	2.4	2.1	1.8	1.35	1.0

V_n	HZ	50	98	300	400	500	>1KHZ
$V > 160$		0.88	1.00	1.20	1.25	1.35	1.40

CAPACITORS DIMENSIONS AND DRILLING PLAN OF PRINTED WIRING BOARD

- AZC SERIES

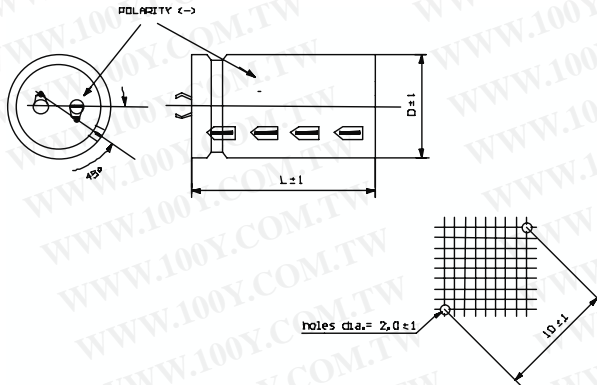

- AZS SERIES (D = 35 / 40 / 45 mm)

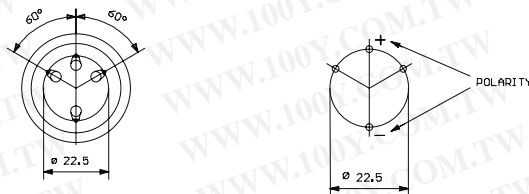

CASE CODE	$\Phi \times l$ (mm)	CASE CODE	$\Phi \times l$ (mm)	CASE CODE	$\Phi \times l$ (mm)	CASE CODE	$\Phi \times l$ (mm)
MB	30 x 40	NN	35 x 60	PN	40 x 60	QE	45 x 75
MC	30 x 50	NE	35 x 75	PG	40 x 100	QG	45 x 100
NB	35 x 40	PB	40 x 40	QC	45 x 50		
NC	35 x 50	PC	40 x 50	QN	45 x 60		

- *The unconnected pins serve as mountings and must be soldered to insulated pads*

EXPECTED LIFE AS A FUNCTION OF TEMPERATURE AND RIPPLE CURRENT

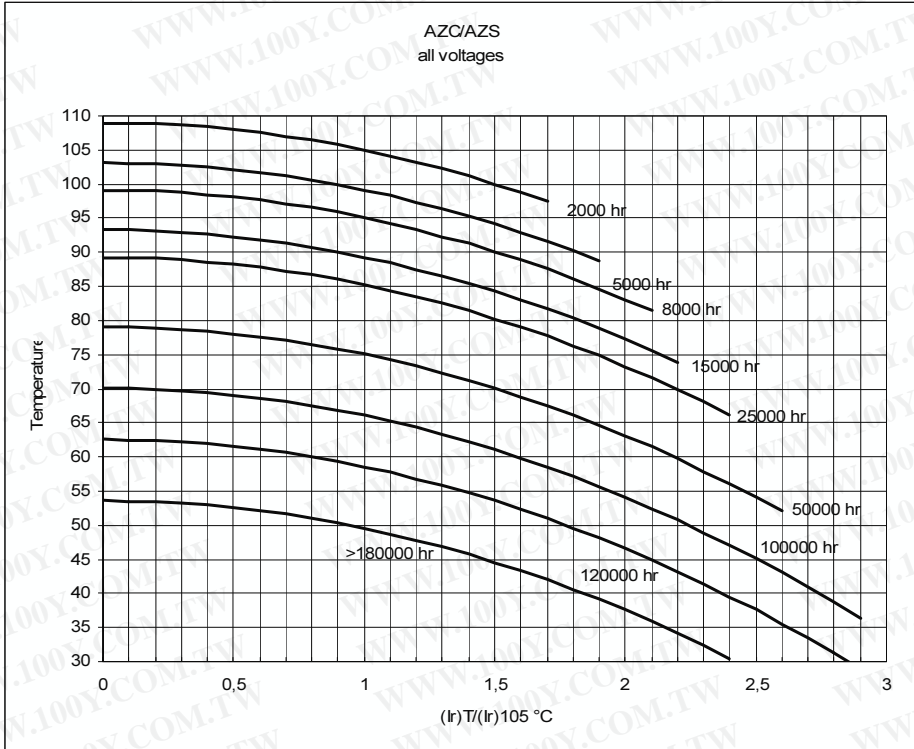

Expected life criteria: see introduction.

CAP (μ F)	Rated Voltage (Vn)	Case Code	Φ x h (mm)	TG δ 100Hz	ESR max 100Hz (mOhm)	ESR typ 100Hz (mOhm)	Z max 10KHz (mOhm)	I ripple 75°C 100Hz (A)	I ripple 105°C 100Hz (A)	CATALOGUE NUMBER	
										2 mounting pins	4 mounting pins
470	200	MB	30 x 40	0,08	203	152	174	3,2	1,5	AZC471M200MB1	
680		MB	30 x 40	0,08	141	105	120	3,9	1,9	AZC681M200MB1	
1000		MC	30 x 50	0,08	96	72	82	5,2	2,5	AZC102M200MC1	
1000		NB	35 x 40	0,08	96	72	82	5,7	2,7	AZC102M200NB1	AZS102M200NB1
1200		NB	35 x 40	0,08	80	60	68	6,2	3,0	AZC122M200NB1	AZS122M200NB1
1500		NC	35 x 50	0,08	64	48	54	6,9	3,3	AZC152M200NC1	AZS152M200NC1
1800		NC	35 x 50	0,08	53	40	46	7,6	3,6	AZC182M200NC1	AZS182M200NC1
2700		NE	35 x 75	0,08	35	27	30	11,1	5,3	AZC272M200NE1	AZS272M200NE1
3300		PG	40 x 100	0,08	29	22	25	15,4	7,3		AZS332M200PG1
2200		QC	45 x 50	0,08	43	33	37	9,7	4,6		AZS222M200QC1
3300		QE	45 x 75	0,08	29	22	25	14,1	6,7		AZS332M200QE1
4700		QG	45 x 100	0,08	20	15	18	19,6	9,3		AZS472M200QG1

CAP (μ F)	Rated Voltage (Vn)	Case Code	Φ x h (mm)	TG δ 100Hz	ESR max 100Hz (mOhm)	ESR typ 100Hz (mOhm)	Z max 10KHz (mOhm)	I ripple 75°C 100Hz (A)	I ripple 105°C 100Hz (A)	CATALOGUE NUMBER	
										2 mounting pins	4 mounting pins
470	250	MB	30 x 40	0,08	203	152	174	3,2	1,5	AZC471M250MB1	
680		MC	30 x 50	0,08	141	105	120	4,3	2,0	AZC681M250MC1	
680		NB	35 x 40	0,08	141	105	120	4,7	2,2	AZC681M250NB1	AZC681M250NB1
1000		NB	35 x 40	0,08	96	72	82	5,7	2,7	AZC102M250NB1	AZC102M250NB1
1000		NC	35 x 50	0,08	96	72	82	5,7	2,7	AZC102M250NC1	AZC102M250NC1
2200		NE	35 x 75	0,08	43	33	37	10,0	4,8	AZC222M250NE1	AZC222M250NE1
1500		PC	40 x 50	0,08	64	48	54	7,5	3,6	AZC152M250PC1	AZC152M250PC1
2200		PG	40 x 100	0,08	43	33	37	12,6	6,0		AZC222M250PG1

CAP (μ F)	Rated Voltage (Vn)	Case Code	Φ x h (mm)	TG δ 100Hz	ESR max 100Hz (mOhm)	ESR typ 100Hz (mOhm)	Z max 10KHz (mOhm)	I ripple 75°C 100Hz (A)	I ripple 105°C 100Hz (A)	CATALOGUE NUMBER	
										2 mounting pins	4 mounting pins
220	385	MB	30 x 40	0,08	434	326	370	2,2	1,1	AZC221M385MB1	
330		MB	30 x 40	0,08	290	217	247	2,7	1,3	AZC331M385MB1	
470		NC	35 x 50	0,08	203	152	156	4,1	1,9	AZC471M385NC1	AZS471M385NC1
470		PB	40 x 40	0,08	203	152	174	3,8	1,8	AZC471M385PB1	AZS471M385PB1
680		NC	35 x 50	0,08	141	105	108	4,9	2,3	AZC681M385NC1	AZS681M385NC1
680		PC	40 x 50	0,08	141	105	108	5,3	2,5	AZC681M385PC1	AZS681M385PC1

CAP (μ F)	Rated Voltage (Vn)	Case Code	Φ x h (mm)	TG δ 100Hz	ESR max 100Hz (mOhm)	ESR typ 100Hz (mOhm)	Z max 10KHz (mOhm)	I ripple 75°C 100Hz (A)	I ripple 105°C 100Hz (A)	CATALOGUE NUMBER	
										2 mounting pins	4 mounting pins
220	400	MB	30 x 40	0,08	434	326	370	2,2	1,1	AZC221M400MB1	
330		MB	30 x 40	0,08	290	217	247	2,7	1,3	AZC331M400MB1	
330		MC	30 x 50	0,08	290	217	247	3,0	1,4	AZC331M400MC1	
470		MC	30 x 50	0,08	203	152	174	3,6	1,7	AZC471M400MC1	
470		NB	35 x 40	0,08	203	152	174	3,9	1,8	AZC471M400NB1	AZS471M400NB1
470		NC	35 x 50	0,08	203	152	174	3,9	1,8	AZC471M400NC1	AZS471M400NC1
560		NC	35 x 50	0,08	171	128	146	4,2	2,0	AZC561M400NC1	AZS561M400NC1
680		NC	35 x 50	0,08	141	105	120	4,7	2,2	AZC681M400NC1	AZS681M400NC1
820		NN	35 x 60	0,08	117	87	82	5,5	2,6	AZC821M400NN1	AZS821M400NN1
1200		NE	35 x 75	0,08	80	60	68	7,4	3,5	AZC471M400NE1	AZS471M400NE1
680		PC	40 x 50	0,08	141	105	120	5,0	2,4	AZC681M400PC1	AZS681M400PC1
1200		PE	40 x 75	0,08	80	60	68	8,0	3,8		AZS122M400PE1
1500		PG	40 x 100	0,08	64	48	54	10,4	4,9		AZS152M400PG1
1000		QC	45 x 50	0,08	96	72	82	6,6	3,1		AZS102M400QC1
1500		QE	45 x 75	0,08	64	48	54	9,5	4,5		AZS152M400QE1
2200		QG	45 x 100	0,08	43	33	37	13,4	6,4		AZS222M400QG1

CAP (μ F)	Rated Voltage (Vn)	Case Code	Φ x h (mm)	TG δ 100Hz	ESR max 100Hz (mOhm)	ESR typ 100Hz (mOhm)	Z max 10KHz (mOhm)	I ripple 75°C 100Hz (A)	I ripple 105°C 100Hz (A)	CATALOGUE NUMBER	
										2 mounting pins	4 mounting pins
150	450	MB	30 x 40	0,10	796	597	652	1,7	0,8	AZC151M450MB1	
220		MB	30 x 40	0,10	543	407	445	2,0	1,0	AZC221M450MB1	
330		MC	30 x 50	0,10	362	271	297	2,7	1,3	AZC331M450MC1	
330		NB	35 x 40	0,10	362	271	297	3,0	1,4	AZC331M450NB1	AZS331M450NB1
470		NC	35 x 50	0,10	254	191	138	4,3	2,1	AZC471M450NC1	AZS471M450NC1
680		NN	35 x 60	0,10	176	132	120	5,0	2,4	AZC681M450NN1	AZS681M450NN1
680		NE	35 x 75	0,10	176	132	132	5,3	2,5	AZC681M450NE1	AZS681M450NE1
820		NE	35 x 75	0,10	146	109	110	5,8	2,8	AZC821M450NE1	AZS821M450NE1
680		PC	40 x 50	0,10	176	132	132	4,8	2,3	AZC681M450PC1	AZS681M450PC1
1000		PE	40 x 75	0,10	119	90	98	6,6	3,2		AZS102M450PE1
1500		PG	40 x 100	0,10	80	60	66	9,5	4,5		AZS152M450PG1
820		QC	45 x 50	0,10	146	109	119	5,4	2,6		AZS821M450QC1
1200		QE	45 x 75	0,10	100	75	82	7,8	3,7		AZS122M450QE1
1800		QG	45 x 100	0,10	66	50	49	11,1	5,3		AZS182M450QG1

ATC - ATS SERIES

ALUMINIUM ELECTROLYTIC CAPACITORS FOR PRINTED WIRING BOARD MOUNTING

Series	Capacitance range	Voltage range	Temperature range	Case $\Phi \times H$	Applications
ATC ATS	100 - 1500	200 - 450	-25°C , +105°C	30 x 40 35 x 75	Long life Snap-in type, 2-4 pins configuration Extended temperature range Solder pin mounting Industrial applications

MECHANICAL OUTLINES:

CASE: cylindrical aluminium made

TERMINALS: to be soldered to a PWB

SEALING: hermetic by beading on a Rubber-Bakelite

PRESSURE RELEASE VENT: directly on to the aluminium case

SLEEVE: self-extinguishing thermoshrinkable sleeve;

MOUNTING: vertical, by soldering to printed circuit board.

SIZE: see enclosed drawings

SPECIFICATIONS	TEMPERATURE RANGE	CAPACITANCE
CECC 30300 IEC 384-4 ("long life grade") MIL C62D DIN 41240 / DIN 45910	Operating: -25 °C/ +105 °C Climatic Category (IEC 68): 25/105/56	Tolerance shall be within the following limits: -20% + 20% (standard tolerance) or -10% +30% (available on request)

LEAKAGE CURRENT:

After the rated voltage has been applied to the capacitor for 5 minutes the leakage current must be:

Maximum limit	at 25 °C	$I_f \leq 0,003 * C * V$
Operating limit	at 25 °C:	$I_f \leq 0,001 * C * V$

where I_f = leakage current (μA)

C= capacitance (μF)

V= rated voltage (V)

IMPORTANT

When using high-capacitance and high-voltage electrolytic capacitors it is important to remember that the inner part (the rolled section) is not insulated from can: between the negative pole and the aluminium can there is a variable and not defined resistance essentially due to the electrolyte used in capacitor manufacture.

SURGE VOLTAGE

Working Voltage	200	250	315	400	420	450
Surge Voltage	230	290	347	440	460	495

RIPPLE CURRENT:

The maximum allowable ripple current in Amperes, are related to the temperature and frequency by the formula:

$$I_r = K_t * K_f * I_{r105}$$

where I_{r105} is the limit of superimposed alternating current, given by the tables referred to temperature of 105°C and to a frequency of 100 Hz and K_f or K_t are values here below tabulated:

°C	50	65	75	85	95	105
K_t	2.4	2.2	2.1	1.8	1.3	1.0

V_n	HZ	50	98	300	400	500	>1KHZ
$V > 160$	K_f	0.88	1.00	1.20	1.25	1.35	1.40

CAPACITORS DIMENSIONS AND DRILLING PLAN OF PRINTED WIRING BOARD

- ATC SERIES

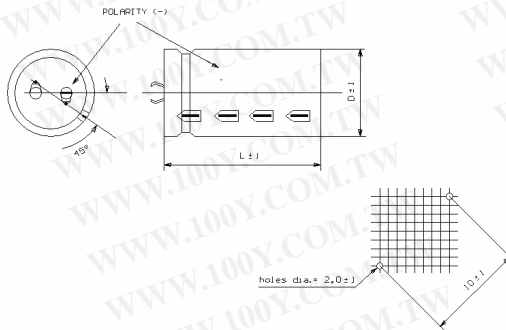

- ATS SERIES (D = 35 / 40 / 45 mm)

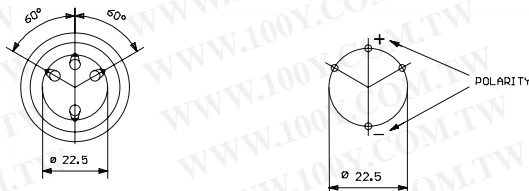

CASE CODE	Φ x l (mm)	CASE CODE	Φ x l (mm)	CASE CODE	Φ x l (mm)
MB	30 x 40	NC	35 x 50	PB	40 x 40
MC	30 x 50	NN	35 x 60	PC	40 x 50
NB	35 x 40	NE	35 x 75		

- only on request
- The unconnected pins serve as mountings and must be soldered to insulated pads

EXPECTED LIFE AS A FUNCTION OF TEMPERATURE AND RIPPLE CURRENT

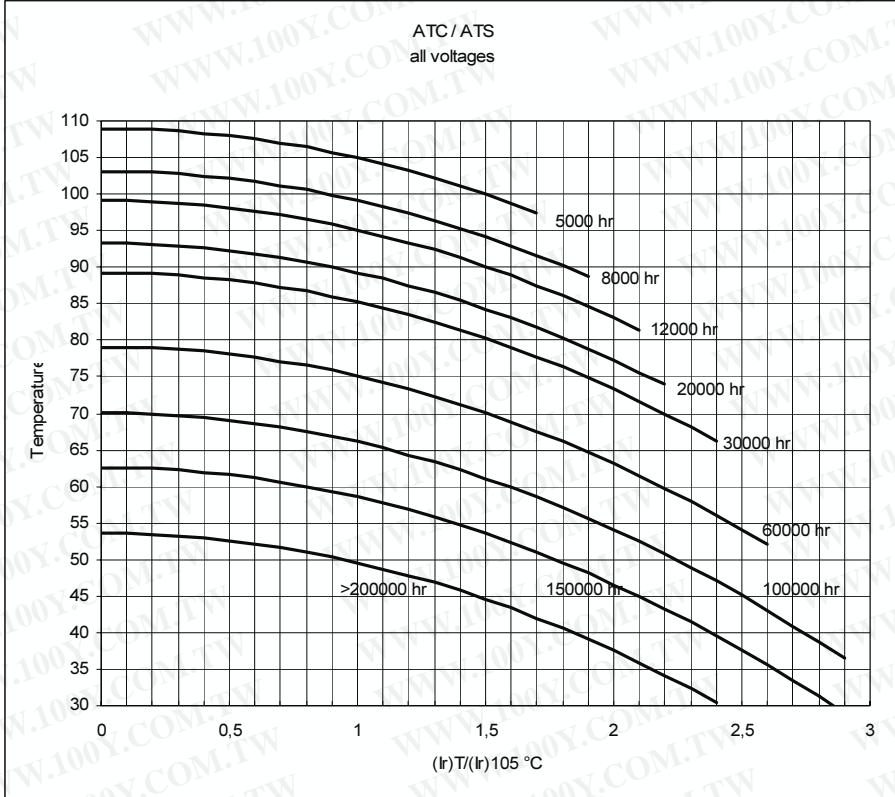

Expected life criteria: see introduction

CAP (μ F)	Rated Voltage (Vn)	Case Code	Φ x h (mm)	TG δ 100Hz	ESR max 100Hz (mOhm)	ESR typ 100Hz (mOhm)	Z max 10KHz (mOhm)	I ripple 85°C 100Hz (A)	I ripple 105°C 100Hz (A)	CATALOGUE NUMBER	
										2 mounting pins	4 mounting pins
470	200	MB	30 x 40	0,08	217	163	176	4,5	2,5	ATC471M250MB1	
680		MC	30 x 50	0,08	150	112	122	6,3	3,3	ATC681M250MC1	
680		NB	35 x 40	0,08	150	112	122	6,6	3,6	ATC681M250NB1	
1000		NC	35 x 50	0,08	102	76	82	7,9	4,4	ATC102M250NC1	ATS102M250NC1
1500		PC	40 x 50	0,08	68	51	55	10,5	5,8	ATC152M250PC1	ATS152M250PC1

CAP (μ F)	Rated Voltage (Vn)	Case Code	Φ x h (mm)	TG δ 100Hz	ESR max 100Hz (mOhm)	ESR typ 100Hz (mOhm)	Z max 10KHz (mOhm)	I ripple 85°C 100Hz (A)	I ripple 105°C 100Hz (A)	CATALOGUE NUMBER	
										2 mounting pins	4 mounting pins
330	250	MB	30 x 40	0,08	309	232	270	3,8	2,1	ATC331M250MB1	
470		MC	30 x 50	0,08	217	163	190	5,0	2,8	ATC471M250MC1	
470		NB	35 x 40	0,08	217	163	190	5,4	3,0	ATC471M250NB1	
680		NC	35 x 50	0,08	150	112	131	6,6	3,6	ATC681M250NC1	ATS681M250NC1
1000		NC	35 x 50	0,08	102	76	89	7,9	4,4	ATC102M250NC1	ATS102M250NC1

CAP (μ F)	Rated Voltage (Vn)	Case Code	Φ x h (mm)	TG δ 100Hz	ESR max 100Hz (mOhm)	ESR typ 100Hz (mOhm)	Z max 10KHz (mOhm)	I ripple 85°C 100Hz (A)	I ripple 105°C 100Hz (A)	CATALOGUE NUMBER	
										2 mounting pins	4 mounting pins
220	385	MB	30 x 40	0,08	463	347	405	3,1	1,7	ATC221M385MB1	
330		MC	30 x 50	0,08	309	232	270	4,2	2,3	ATC331M385MC1	
330		NB	35 x 40	0,08	309	232	270	4,6	2,5	ATC331M385NB1	
470		NC	35 x 50	0,08	217	163	190	5,4	3,0	ATC471M385NC1	ATS471M385NC1
680		PC	40 x 50	0,08	150	112	118	7,5	4,1	ATC681M385PC1	ATS681M385PC1

CAP	Rated Voltage (Vn)	Case Code	Φ x h (mm)	TG δ 100Hz	ESR max	ESR typ	Z max	I ripple 85°C	I ripple 105°C	CATALOGUE NUMBER	
					100Hz (mOhm)	100Hz (mOhm)	10Khz (mOhm)	100Hz (A)	100Hz (A)	2 mounting pins	4 mounting pins
220	400	MB	30 x 40	0,08	463	347	405	3,1	1,7	ATC221M385MB1	
330		MC	30 x 50	0,08	309	232	270	4,2	2,3	ATC331M385MC1	ATS331M385MC1
330		NB	35 x 40	0,08	309	232	270	4,6	2,5	ATC331M385NB1	ATS331M385NB1
470		NC	35 x 50	0,08	217	163	190	5,4	3,0	ATC471M385NC1	ATS471M385NC1
560		PC	40 x 50	0,08	182	136	159	6,4	3,6	ATC561M385PC1	ATS561M385PC1
680		NE	35 x 75	0,08	150	112	131	8,4	4,7	ATC681M385NE1	ATS681M385NE1

CAP	Rated Voltage (Vn)	Case Code	Φ x h (mm)	TG δ 100Hz	ESR max	ESR typ	Z max	I ripple 55°C	I ripple 105°C	CATALOGUE NUMBER	
					100Hz (mOhm)	100Hz (mOhm)	10Khz (mOhm)	100Hz (A)	100Hz (A)	2 mounting pins	4 mounting pins
150	450	MB	30 x 40	0,10	849	637	718	2,3	1,3	ATC151M385MB1	
220		MC	30 x 50	0,10	579	434	486	3,1	1,7	ATC221M385MC1	
220		NB	35 x 40	0,10	579	434	486	3,4	1,9	ATC221M385NB1	
330		NC	35 x 50	0,10	386	290	380	4,2	2,3	ATC331M385NC1	ATS331M385NC1
470		NE	35 x 75	0,10	271	203	228	6,4	3,6	ATC471M385NE1	ATS471M385NE1

MOUNTING HARDWARE

MOUNTING HARDWARE

RING CLIPS (Dimensions in mm.)

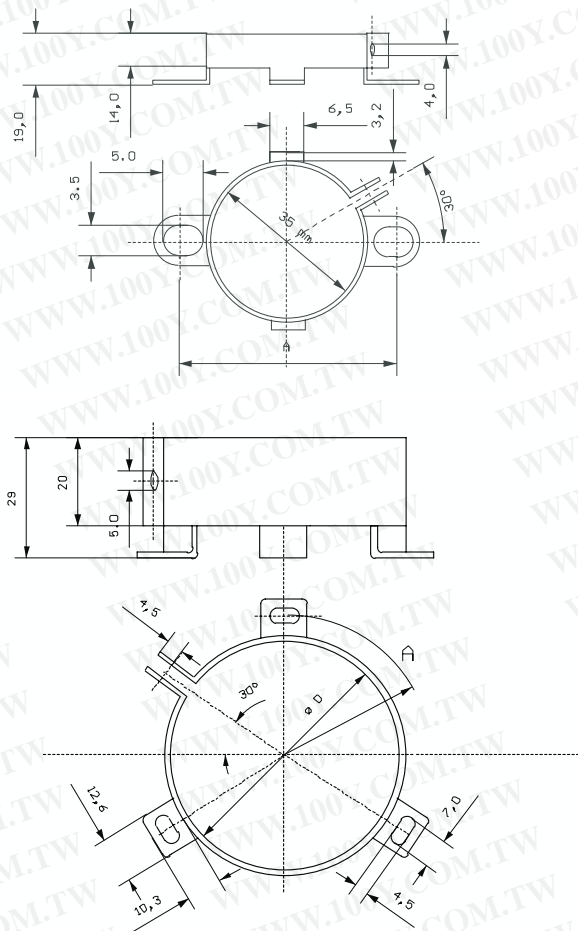

Ring clip code	D	A
ZAF-A	35	46
ZAF B	51	63,5
ZAF C	63	76
ZAF D	76	89
ZAF E	90	106

MOUNTING HARDWARE

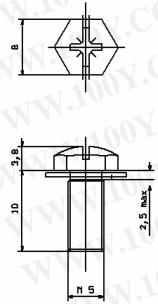
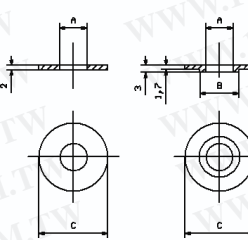
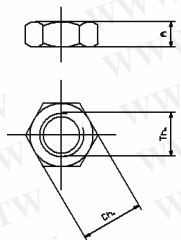
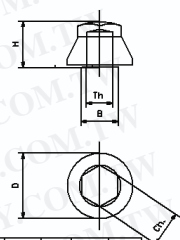
<p style="text-align: center;">SCREW</p> 	<p style="text-align: center;">INSULATED WASHERS</p>  <table border="1" style="margin-left: auto; margin-right: auto;"> <tr> <td>A</td> <td>C</td> </tr> <tr> <td>8</td> <td>25</td> </tr> <tr> <td>12</td> <td>35</td> </tr> </table> <table border="1" style="margin-left: auto; margin-right: auto;"> <tr> <td>A</td> <td>B</td> <td>C</td> </tr> <tr> <td>8</td> <td>18</td> <td>25</td> </tr> <tr> <td>12</td> <td>18</td> <td>35</td> </tr> </table>	A	C	8	25	12	35	A	B	C	8	18	25	12	18	35																											
A	C																																										
8	25																																										
12	35																																										
A	B	C																																									
8	18	25																																									
12	18	35																																									
<p style="text-align: center;">METAL NUTS</p>  <table border="1" style="margin-left: auto; margin-right: auto;"> <tr> <th>P/N</th> <th>Th</th> <th>A</th> <th>Ch</th> </tr> <tr> <td>1121</td> <td>M8</td> <td>18</td> <td>17</td> </tr> <tr> <td>1277</td> <td>M12</td> <td>18</td> <td>19</td> </tr> </table>	P/N	Th	A	Ch	1121	M8	18	17	1277	M12	18	19	<p style="text-align: center;">PLASTIC HEX NUTS (ON REQUEST)</p>  <table border="1" style="margin-left: auto; margin-right: auto;"> <tr> <th>P/N</th> <th>Th</th> <th>B</th> <th>D</th> <th>H</th> <th>Ch</th> </tr> <tr> <td>1210</td> <td>M8</td> <td>18</td> <td>25</td> <td>15</td> <td>17</td> </tr> <tr> <td>1126</td> <td>M12</td> <td>18</td> <td>30</td> <td>20</td> <td>19</td> </tr> <tr> <td>1502</td> <td>M12</td> <td>22.5</td> <td>30</td> <td>18</td> <td>19</td> </tr> <tr> <td>1508</td> <td>M12</td> <td>30</td> <td>38</td> <td>18</td> <td>19</td> </tr> </table>	P/N	Th	B	D	H	Ch	1210	M8	18	25	15	17	1126	M12	18	30	20	19	1502	M12	22.5	30	18	19	1508	M12	30	38	18	19
P/N	Th	A	Ch																																								
1121	M8	18	17																																								
1277	M12	18	19																																								
P/N	Th	B	D	H	Ch																																						
1210	M8	18	25	15	17																																						
1126	M12	18	30	20	19																																						
1502	M12	22.5	30	18	19																																						
1508	M12	30	38	18	19																																						