



SALES PROGRAM AND TECHNICAL HANDBOOK

勝特力材料 886-3-5753170
勝特力电子(上海) 86-21-54151736
勝特力电子(深圳) 86-755-83298787
[Http://www.100y.com.tw](http://www.100y.com.tw)



Primary Lithium Cells
Li-MnO₂

勝特力材料 886-3-5753170
 勝特力电子(上海) 86-21-54151736
 勝特力电子(深圳) 86-755-83298787
[Http://www.100y.com.tw](http://www.100y.com.tw)

CONTENT

1.	GENERAL INFORMATION	3-8
1.1	Constructions of Lithium Cells	4-5
1.2	Characteristics and Applications	6
1.3	Applications for Primary Lithium Cells	7
1.4	Selection Guide	8
2.	CR PRIMARY LITHIUM BUTTON CELLS	9-18
2.1	Types – Technical Data	10
2.2	Assemblies	11-13
2.3	Performance Data	14-18
3.	CR HIGH CAPACITY PRIMARY LITHIUM CYLINDRICAL CELLS	19-24
3.1	Types – Technical Data	20
3.2	Assemblies	21
3.3	Performance Data	22-24
4.	CR HIGH POWER PRIMARY LITHIUM CYLINDRICAL CELLS	25-30
4.1	Types – Technical Data	26
4.2	Assemblies	26
4.3	Performance Data	27-30
5.	GENERAL DESIGN CHARACTERISTICS	31-37
5.1	Safety Tests	33
5.2	Safety Guidelines	34-35
5.3	Transportation of VARTA Microbattery Lithium Cells and Batteries	36
5.4	Application Check List	37

Subject to change without further notice. Errors excepted. For latest technical data please refer to our data sheets which you will find on our website www.varta-microbattery.com.

© by VARTA Microbattery GmbH

1. GENERAL INFORMATION

勝特力材料 886-3-5753170
勝特力电子(上海) 86-21-54151736
勝特力电子(深圳) 86-755-83298787
Http://www.100y.com.tw

The VARTA Microbattery lithium manganese dioxide cell chemistry was one of the first solid cathode cells commercially developed and is still the most widely used system today. These cells offer an excellent shelf life, good high-rate and low-rate capability, a wide operating temperature range and availability in button and cylindrical cell designs. Potential design-in

applications for these products are electronic, telecommunication, metering, instrumentation, office and other portable equipment use. Based on the outstanding cell performance and reliability of these products, they have been able to meet and exceed the requirements of our customer base worldwide.

Advantages for VARTA Microbattery Li-MnO₂ Cells

- High open circuit and load voltage (above 3.0 volts per cell)
- High energy density (400 Wh/kg and 600 Wh/l)
- High capacity and high rate cell construction
- Operation over a wide temperature range
- Flat discharge profile under low to medium rate applications
- Low self discharge (less than 1% per year at RT)
- Superior shelf life and operational life (Up to 10 years and more)
- UL Recognition
- Ability to provide a variety of laser welded termination tabs for all cell types

Energy Density for Primary Systems

FIG. 1
Comparison of different primary battery systems

- A = Lithium
- B = Silver-oxide
- C = Alkaline
- D = Zinc-chloride

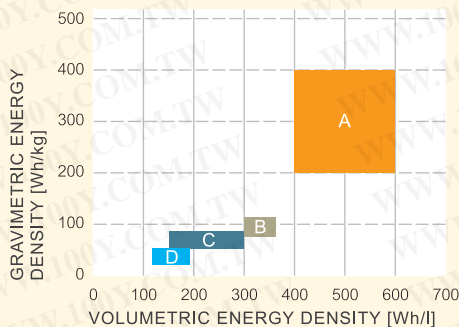

勝特力材料 886-3-5753170
 勝特力电子(上海) 86-21-54151736
 勝特力电子(深圳) 86-755-83298787
[Http://www.100y.com.tw](http://www.100y.com.tw)

1.1 CONSTRUCTIONS OF LITHIUM CELLS

VARTA Microbattery offers a complete range of primary lithium manganese dioxide cylindrical and button cells for memory backup and portable applications worldwide. The cylindrical cell configurations offer the high-capacity bobbin construction and high-power spirally wound product. The bobbin construction is targeted at low to moderate power requirements, dedicated for applications

requiring up to a 10 years operational life at 20°C. Our spirally wound electrode product offers high-rate discharge capability, with an operational life in excess of 5 years.

For compact and light weight equipment use we have a complete range of high performance primary lithium button cells.

Lithium Cylindrical Batteries

FIG. 2 – BOBBIN CONSTRUCTION

Schematic construction of a Li/MnO₂ cylindrical cell (CR 1/2 AA).

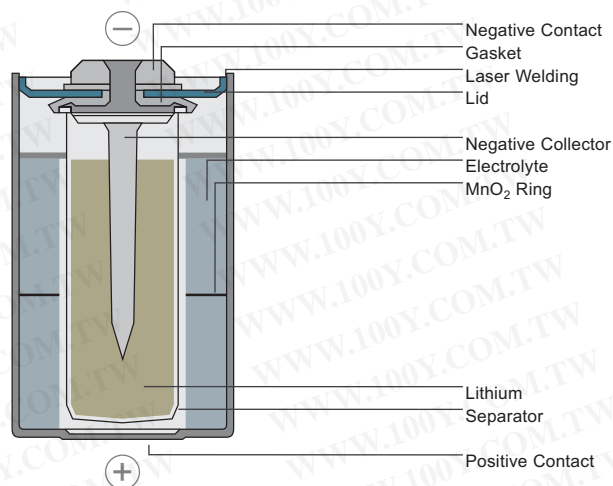
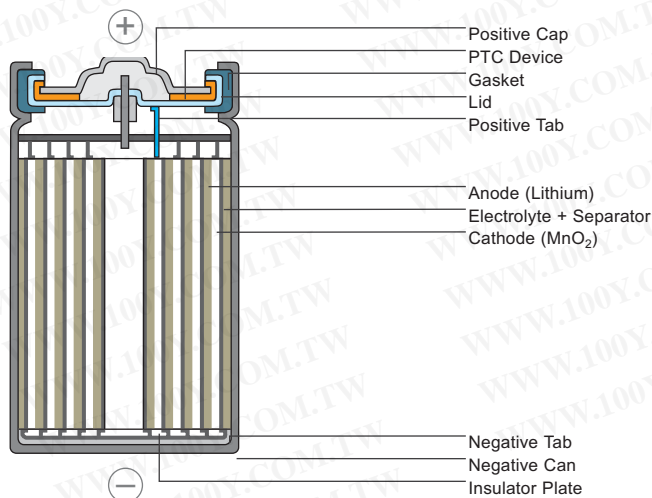

FIG. 3 – SPIRAL CONSTRUCTION

Schematic construction of a Li/MnO₂ cylindrical cell (CR 1/2 AA).



勝特力材料 886-3-5753170
 勝特力电子(上海) 86-21-54151736
 勝特力电子(深圳) 86-755-83298787
[Http://www.100y.com.tw](http://www.100y.com.tw)

Lithium Button Cells

FIG. 4
 Schematic construction of a
 Li/MnO₂ Button Cell

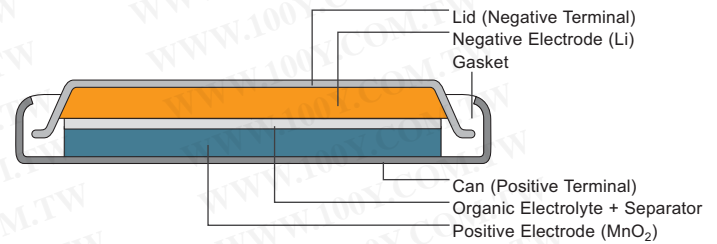

Sealing Technologies

FIG. 5 - CRIMP-SEALING
 CR High Power Cylindrical Cells

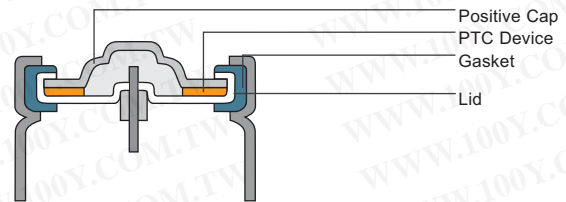
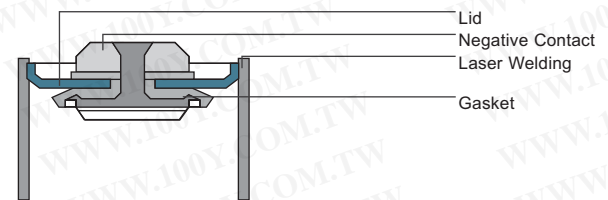

FIG. 6 - LASER-SEALING
 CR High Capacity Cylindrical Cells



1.2 CHARACTERISTICS AND APPLICATIONS

Main Applications

Both mechanical and electrical properties, together with reliability, ensure that VARTA Microbattery lithium batteries meet the requirements of modern electronics.

They are therefore ideally suited as power sources for the long term supply of microelectronic circuitry.

Main Characteristics

- Long life expectancy and long operational life
- Low self discharge rate
- High energy density
- High cell voltage (3V)
- Wide temperature range
- High operating safety
- High reliability
- Resistance to corrosion with stainless steel case
- No leakage problems with an organic non-corrosive electrolyte

Temperature characteristics

FIG. 7

Temperature characteristics of CR 1/2 AA and CR AA cylindrical cells
 (Load: 5.6 k Ω CR AA, 12 k Ω CR 1/2 AA)

A = -40°C
 B = +80°C
 C = +60°C
 D = -20°C
 E = +23°C

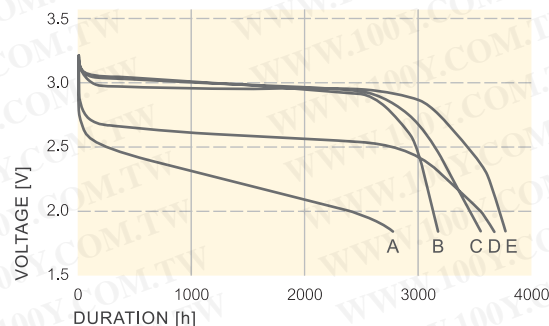

System properties of Varta Microbattery Lithium Cells

Series	CR Series Cylindrical Cells	CR Series Button Cells
System	Li/MnO ₂	Li/MnO ₂
Gravimetric energy density	250–300 Wh/kg	250–300 Wh/kg
Nominal voltage	3.0 V	3.0 V
Open circuit voltage	3.2 V	3.2 V
Available capacity range	950–2000 mAh	25–560 mAh
Storage life	Δ 10 years ¹⁾	Δ 5 years ¹⁾
Self discharge d=20°C	<1% p.a.	<1% p.a.
Operating temperature	-30 ... +75°C ²⁾	-20 ... +65°C
Maximum temperature range (short term) ³⁾	-40 ... +80°C ⁴⁾	-40 ... +80°C ⁴⁾
Storage temperature ⁵⁾	-55 ... +75°C ²⁾	-55...+70°C

TAB. 1

¹⁾ CR 2/3 AH, CR 2, (>5 years)

²⁾ CR 2/3 AH (-20 ... +65°C)

³⁾ max. two weeks

⁴⁾ μ A-range

⁵⁾ Recommended room temperature

1.3 APPLICATIONS FOR PRIMARY LITHIUM CELLS

Applications	Button Cells		Cylindrical Cells (Spirally wound)		Cylindrical Cells (Bobbin construction)	
	Main power source	Memory backup	Main power source	Memory backup	Main power source	Memory backup
Telecommunications						
Std. Telephone		+		+		+
Cordless Telephone		+		+		+
Cellular Telephone		+				
Mobile Radio		+		+		+
PABX				+		+
Utility Meters						
Gas Meter			+		+	
Heat Distribution Meter					+	
Electric Meter					+	
Water Meter			+		+	
Office Automation						
Computer		+				+
Copy Machine				+		+
Printer		+				
Fax		+				
Vending Machine		+				
Electronic Typewriter		+				
Process Control Equipment						
Taxi Meter		+				
Transponder			+			
Intelligent Tagging	+					
Electric Parking Meter			+		+	
Data Logger						+
Dive Computer					+	
Consumer Products						
Electronic Games	+					
Watch / Clock	+		+			+
Calculator	+					
Compass				+		+
Car Radio		+				
Video Recorder		+				
Automotive						
Car lock system	+					
Dashboard	+	+				
Security		+				

TAB. 2
Application list

勝特力材料 886-3-5753170
 勝特力电子(上海) 86-21-54151736
 勝特力电子(深圳) 86-755-83298787
[Http://www.100y.com.tw](http://www.100y.com.tw)

1.4 SELECTION GUIDE

To enable battery selection the following is required:

- discharge current and maximum discharge time
 - capacity
- operating temperature range
 - self discharge
 - surplus capacity requirement
- cell size

FIG. 8
CAPACITY RETENTION
 Capacity retention characteristics of VARTA Microbattery Lithium Cells Cylindrical Cells CR...AA and CR...A

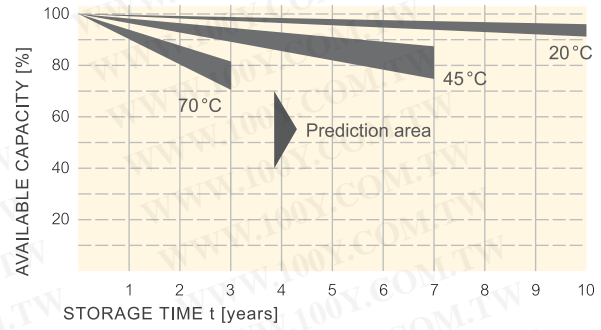

FIG. 9
STORAGE BEHAVIOR
 Typical storage behaviour at room temperature 21°C of CR 1/2 AA

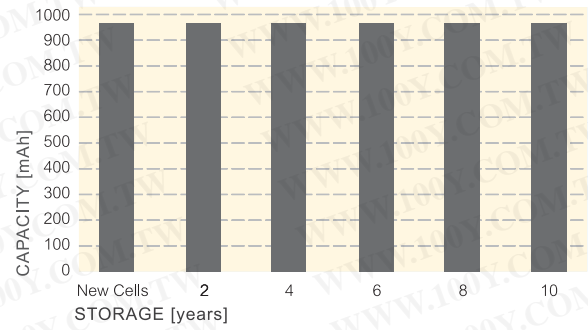
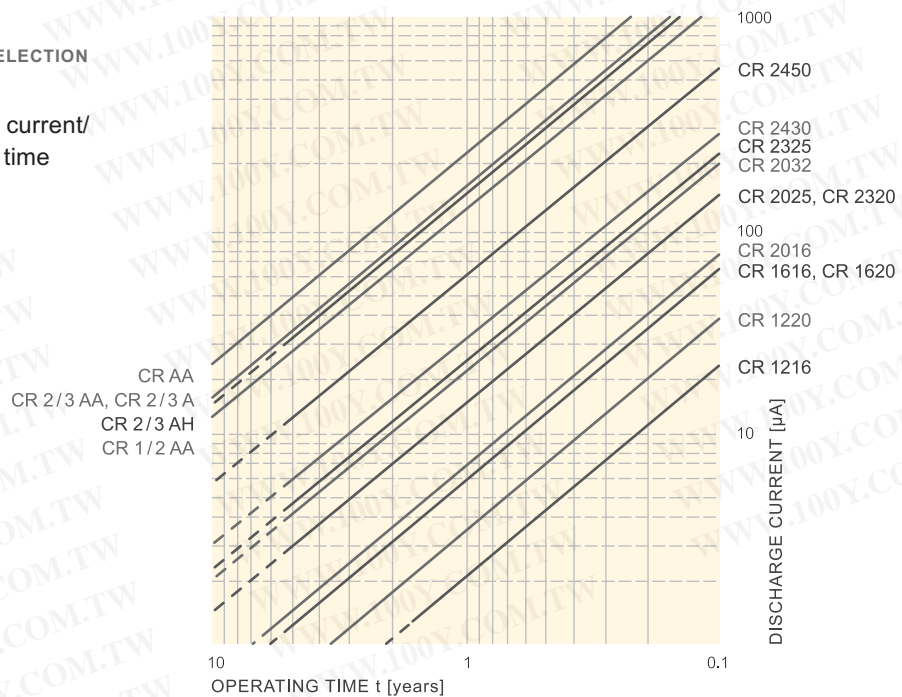

FIG. 10
BATTERY SELECTION DIAGRAMM
 Discharge current/ Operating time



2. CR PRIMARY LITHIUM BUTTON CELLS



勝特力材料 886-3-5753170
勝特力电子(上海) 86-21-54151736
勝特力电子(深圳) 86-755-83298787
[Http://www.100y.com.tw](http://www.100y.com.tw)

勝特力材料 886-3-5753170
 勝特力电子(上海) 86-21-54151736
 勝特力电子(深圳) 86-755-83298787
[Http://www.100y.com.tw](http://www.100y.com.tw)

2.1 TYPES – TECHNICAL DATA



Type	Order No.	Nominal voltage (V)	Typical capacity ¹⁾ (mAh)	Standard load (kΩ)	Max. discharge current (continuous) (mA)	Max. discharge current (pulse) (mA)	Weight (g)
CR 1/3 N	6131 101 501	3	170	5.6	20	80	3.0
2 CR 1/3 N (p28 pxl)	6231 210 501	6	170	13	20	80	8.8
CR 1216	6216 101 501	3	27	39	2	5	0.7
CR 1220	6220 101 501	3	35	39	2	5	0.8
CR 1616	6616 101 501	3	55	39	3	8	1.2
CR 1620	6620 101 501	3	70	20	3	8	1.2
CR 2016	6016 101 501	3	90	15	3	10	1.8
CR 2025	6025 101 501	3	165	10	3	10	2.5
CR 2032	6032 101 501	3	230	5.6	3	10	3.0
CR 2430	6430 101 501	3	280	5.6	3	20	4.0
CR 2450	6450 101 501	3	560	5.6	2	20	6.2

TAB. 3

Technical data, CR Primary Lithium Button Cells

¹⁾ Nominal capacity is determined to an end voltage of 2.0 V (type 2 CR 1/3 N: 4.0 V) when the battery is allowed to discharge at standard load level at 20°C

勝特力材料 886-3-5753170
 勝特力电子(上海) 86-21-54151736
 勝特力电子(深圳) 86-755-83298787
[Http://www.100y.com.tw](http://www.100y.com.tw)

2.2 ASSEMBLIES



CR 1/3 N

Type	Order No.	A	B	C	D	E	F	G	H	I	K	L	Fig. No.	Remarks
CR 1/3 N	6131 101 501	11.6	10.8	0.4	-	7.8	-	-	-	-	-	-	11	-
CR 1/3 N SLF	6131 201 501	13.0	1.0	10.0	1.0 ±0.3	11.5 ±0.5	12.0 ±0.15	-	1.0 ±0.3	3.0	-	-	14	tag 0.25 mm
CR 1/3 N LF	6131 301 501	-	-	-	-	11.5	12.0	-	-	-	19.0	4.0	13	tag 0.25 mm 180°
2 CR 1/3 N (p 28 pxl)	6231 210 501	13.0	25.1	1.1	0.6	5.5	6.0	-	-	-	-	-	12	-
3 CR 1/3 N	6331 101 501	12.2	32.2	0.4	-	7.8	-	-	-	-	-	-	11	-

TAB. 4

Tag material: nickel plated sheet-steel. SLF: tip tinned.

Custom made assemblies are available on request for large volume.

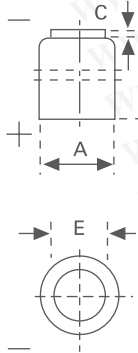

FIG. 11

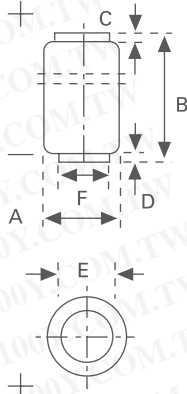

FIG. 12

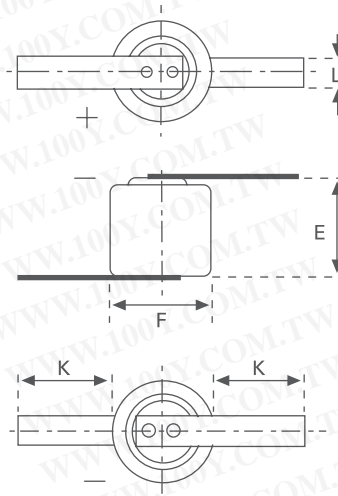

FIG. 13 LF

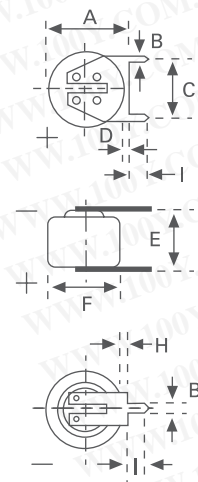

FIG. 14 SLF

勝特力材料 886-3-5753170
勝特力电子(上海) 86-21-54151736
勝特力电子(深圳) 86-755-83298787
[Http://www.100y.com.tw](http://www.100y.com.tw)

Type	Order No.	A	B	C	D	E	F	G	H	I	K	L	Fig. No.	Remarks
CR 1216	6216 101 501	12.5	1.6	0.2	-	10.0	-	-	-	-	-	-	15	
CR 1220	6220 101 501	12.5	2.0	0.3	-	10.0	-	-	-	-	-	-	15	
CR 1616	6616 101 501	16.0	1.6	0.2	-	12.0	-	-	-	-	-	-	15	
CR 1620	6620 101 501	16.0	2.0	0.02	-	12.9	-	-	-	-	-	-	15	
CR 2016	6016 101 501	20.0	1.6	0.1	-	-	-	-	-	-	-	-	15	
CR 2016 SLF	6016 201 501	21.3	1.0	10.0 ±0.15	1.0 ±0.3	2.1 ±0.5	20.3 ±0.15	-	1.0 ±0.3	4.5	-	-	16	tag 0.25 mm
CR 2016 LF	6016 301 501	20.0	-	-	-	1.9	20.0	-	-	-	10.0	4.0	17	tag 0.15 mm
CR 2016 PCB	6016 401 501	20.0	1.0	10.0	9.1	1.6	17.8	7.3	10.0	4.5	11.4	-	18	tag 0.15 mm
CR 2016 SMT	6016 301 012	20.5	3.5	1.8	3.0	2.2	-	-	-	-	-	-		
CR 2025	6025 101 501	20.0	2.5	0.2	-	-	-	-	-	-	-	-	15	
CR 2025 SLF	6025 201 501	21.3	1.0	10.0 ±0.2	1.0 ±0.3	3.0 ±0.5	20.3 ±0.15	-	1.0 ±0.3	4.5	-	-	16	tag 0.25 mm
CR 2025 LF	6025 301 501	20.0	-	-	-	2.8	20.3	-	-	-	10.0	4.0	17	tag 0.15 mm
CR 2025 PCB	6025 401 501	20.0	1.0	10.0	10.0	2.5	17.8	7.3	10.0	4.5	11.4	-	18	tag 0.15 mm

TAB. 5.1

Tag material: nickel plated sheet-steel. SLF: tip tinned.

Custom made assemblies are available on request for large volume.

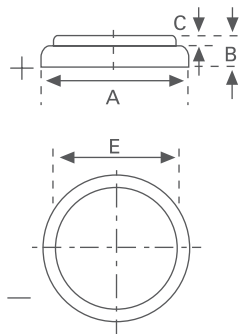

FIG. 15

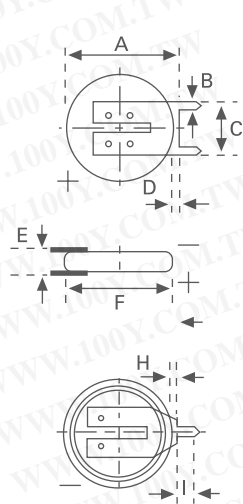

FIG. 16 SLF

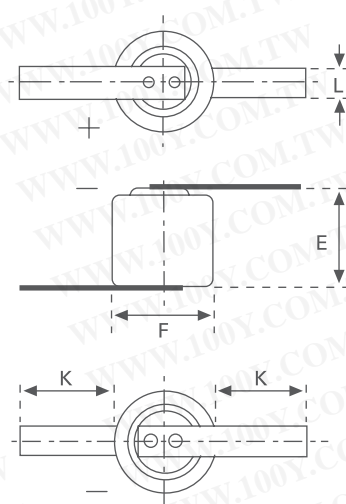

FIG. 17 LF

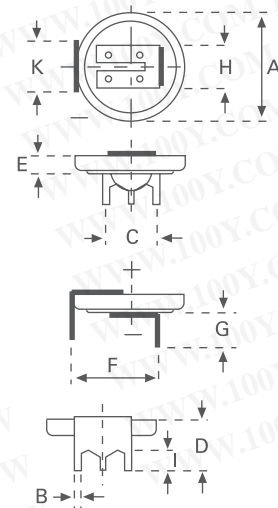

FIG. 18 PCB 3

勝特力材料 886-3-5753170
 勝特力电子(上海) 86-21-54151736
 勝特力电子(深圳) 86-755-83298787
 Http://www.100y.com.tw

Type	Order No.	A	B	C	D	E	F	G	H	I	K	L	Fig. No.	Remarks
CR 2032	6032 101 501	20.0	3.2	0.02	-	16.5	-	-	-	-	-	-	15	-
CR 2032 SLF	6032 201 501	21.5	1.0	10.0	1.0	4.2	20.3	-	1.0	4.5	-	-	16	tag 0.25 mm
CR 2032 LF	6032 301 501	-	-	-	-	3.2	20.3	-	-	-	10	4.0	17	tag 0.15 mm
CR 2032 PCB 3	6032 401 501	20.0	1.0	10.0	11.0	3.2	17.8	7.5	10.0	4.5	11.4	-	18	tag 0.25 mm
CR 2032 PCB 2	6032 701 501	20.0	1.0	-	11.0	3.2	17.8	7.3	10.0	4.5	10.0	-	19	tag 0.20 mm
CR 2032 WC ¹⁾	6032 101 013	20.7	-	-	-	5.5	30.0	-	-	-	96.0	2.0	20	tag 0.20 mm ²⁾
CR 2032 SMT	6032 301 012	20.0	7.0	2.8	5.0	3.8	-	-	-	-	-	-	21	-
CR 2430	6430 101 501	24.5	3.0	0.3	-	20.0	-	-	-	-	-	-	15	-
CR 2430 SLF	6430 201 501	25.8	1.0	10.0	1.0	4.0	25.0	-	1.0	4.5	-	-	16	tag 0.25 mm
CR 2430 LF	6430 301 501	-	-	-	-	3.2	25.0	-	-	-	10.0	4.0	17	tag 0.15 mm
CR 2430 PCB 3	6430 401 501	24.5	1.0	10.0	11.0	3.0	17.8	7.5	10.0	4.5	11.4	-	18	tag 0.25 mm
CR 2430 PCB 2	6430 701 501	24.5	1.0	-	11.0	3.0	20.0	7.5	10.0	4.5	11.4	-	19	tag 0.20 mm
CR 2430 SMT	6430 301 012	24.5	5.2	4.0	5.0	3.3	-	-	-	-	-	-	21	-
CR 2450	6450 101 501	24.7	5.0	0.5	-	21.8	-	-	-	-	-	-	15	-
CR 2450 SLF	6450 201 501	25.8	1.0	10.0	1.0	6.0	25.0	-	1.0	4.5	-	-	16	tag 0.25 mm
CR 2450 PCB 3	6450 401 501	24.5	1.0	10.0	13.2	5.0	17.8	7.5	10.0	4.5	11.4	-	18	tag 0.25 mm
CR 2450 PCB 2	6450 701 501	24.7	1.0	-	12.7	5.0	17.8	7.5	10.0	4.5	11.4	-	19	tag 0.20 mm
CR 2450 SMT	6450 301 012	24.5	4.5	2.8	3.5	5.3	-	-	-	-	-	-	21	-

TABLE 5.2

Tag material: nickel plated sheet-steel. SLF: tip tinned.

¹⁾ using Molex 51021-03 connector (Other wire connectors and wire length are available on request.) ²⁾ in shrink sleeve with wire and connector

Custom made assemblies are available on request for large volume.

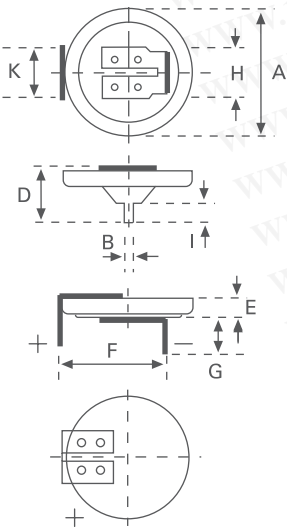

FIG. 19 PCB 2

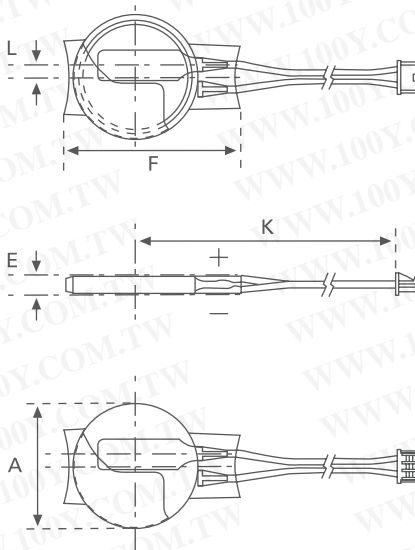

FIG. 20 WC

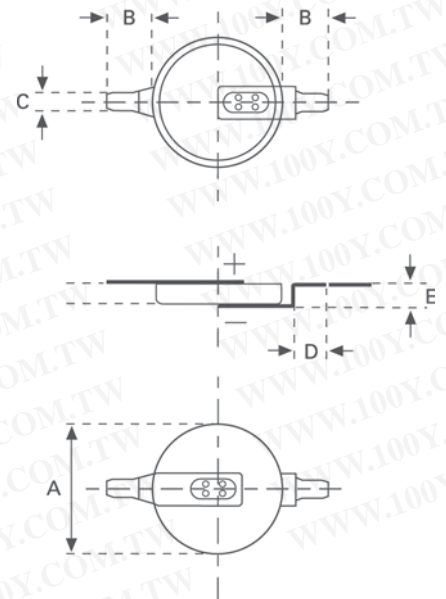

FIG. 21 SMT

2.3 PERFORMANCE DATA

勝特力材料 886-3-5753170
 勝特力电子(上海) 86-21-54151736
 勝特力电子(深圳) 86-755-83298787
[Http://www.100y.com.tw](http://www.100y.com.tw)

FIG. 22 – CR 1216
 Discharge characteristics
 at room temperature (21°C)

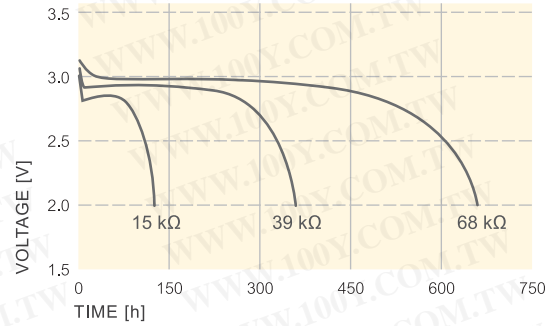

FIG. 23 – CR 1216
 Temperature characteristics
 Constant load 39 kΩ

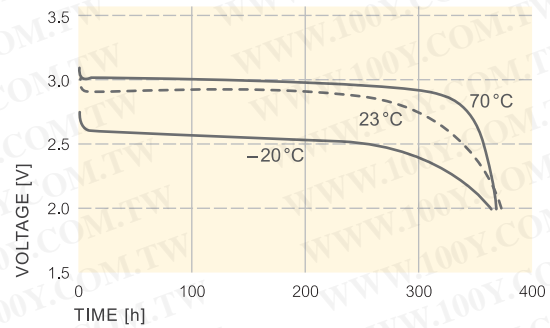

FIG. 24 – CR 1216
 Operating voltage vs. current drain
 Voltage at 50% discharge

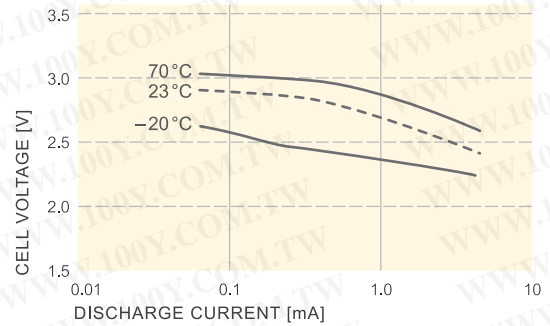
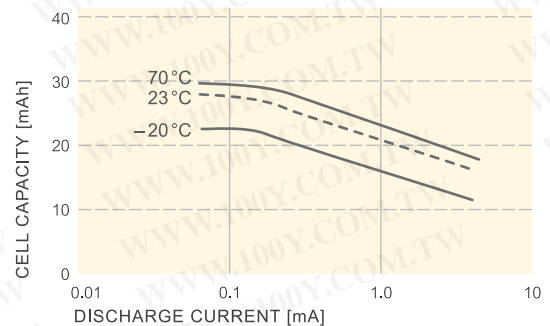

FIG. 25 – CR 1216
 Cell capacity vs. discharge current



勝特力材料 886-3-5753170
 勝特力电子(上海) 86-21-54151736
 勝特力电子(深圳) 86-755-83298787
[Http://www.100y.com.tw](http://www.100y.com.tw)

FIG. 26 – CR 2016
 Discharge characteristics
 at room temperature (21°C)

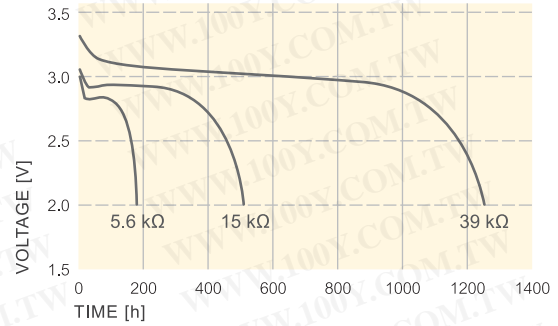

FIG. 27 – CR 2016
 Temperature characteristics
 Constant load 15 kΩ

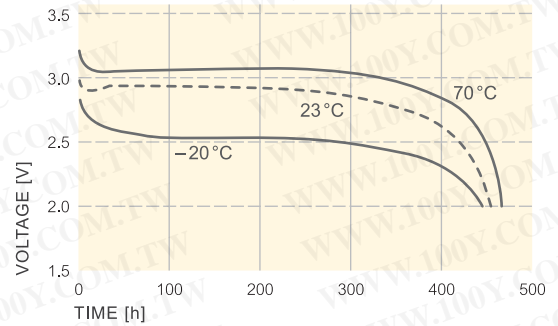

FIG. 28 – CR 2016
 Operating voltage vs. current drain
 Voltage at 50% discharge

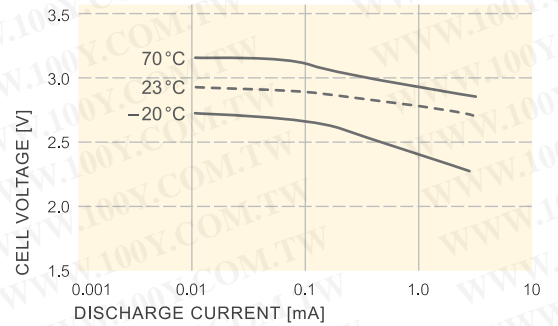
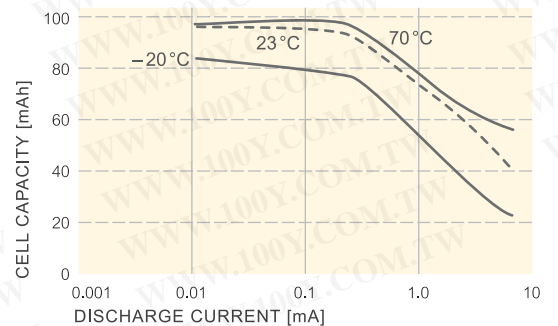

FIG. 29 – CR 2016
 Cell capacity vs. discharge current



勝特力材料 886-3-5753170
勝特力电子(上海) 86-21-54151736
勝特力电子(深圳) 86-755-83298787
Http://www.100y.com.tw

FIG. 30 – CR 2025
 Discharge characteristics
 at room temperature (21°C)

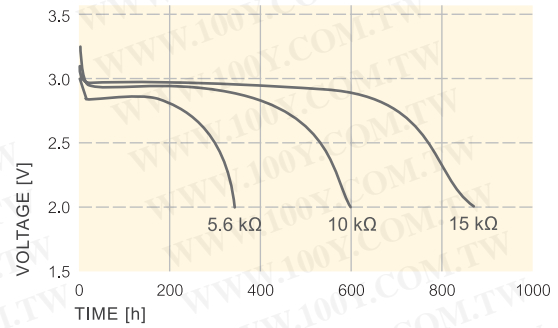

FIG. 31 – CR 2025
 Temperature characteristics
 Constant load 10 kΩ

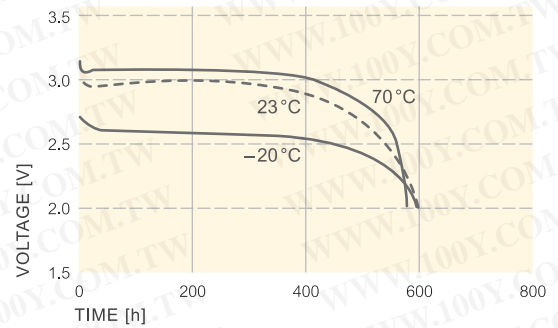

FIG. 32 – CR 2025
 Operating voltage vs. current drain
 Voltage at 50% discharge

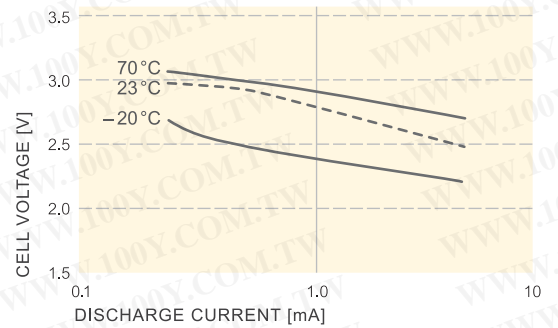
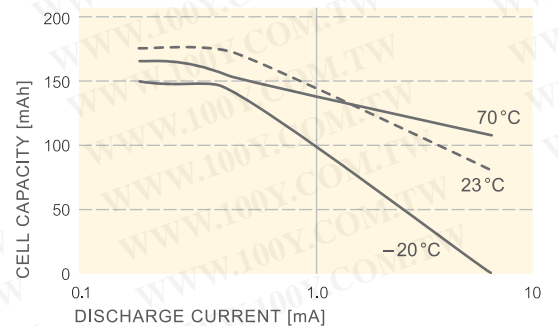

FIG. 33 – CR 2025
 Cell capacity vs. discharge current



勝特力材料 886-3-5753170
 勝特力电子(上海) 86-21-54151736
 勝特力电子(深圳) 86-755-83298787
[Http://www.100y.com.tw](http://www.100y.com.tw)

FIG. 34 – CR 2032
 Discharge characteristics
 at room temperature (21°C)

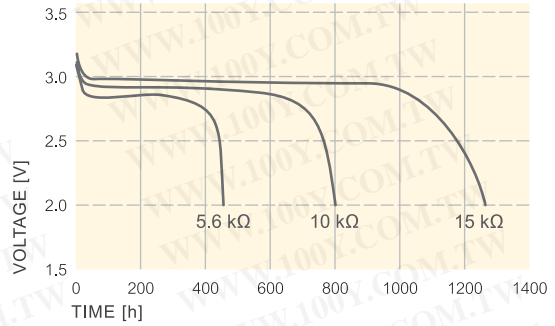

FIG. 35 – CR 2032
 Temperature characteristics
 Constant load 5.6 kΩ

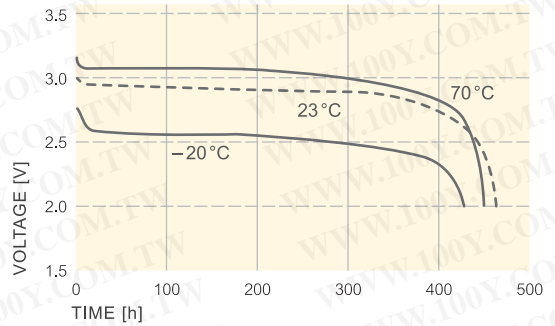

FIG. 36 – CR 2032
 Operating voltage vs. current drain
 Voltage at 50% discharge

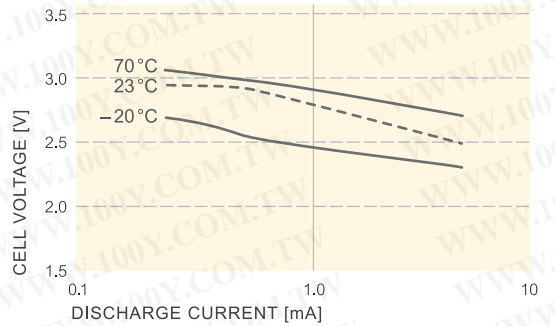
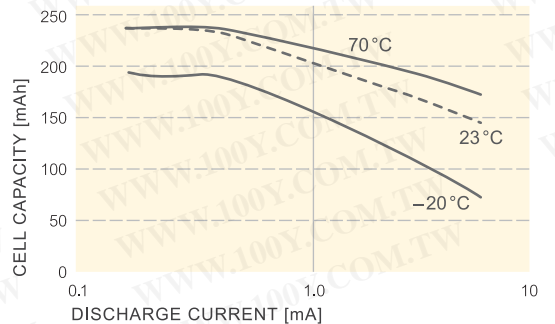

FIG. 37 – CR 2032
 Cell capacity vs. discharge current



勝特力材料 886-3-5753170
 勝特力电子(上海) 86-21-54151736
 勝特力电子(深圳) 86-755-83298787
[Http://www.100y.com.tw](http://www.100y.com.tw)

FIG. 38 – CR 2430

Load: cont. 5.6 kΩ: U_b
 Pulse: 2 s/2 h 390 Ω: U_t
 (parallel)
 Internal Resistance R_i calculated from
 U_b and U_t at $R_t = 390 \Omega$ and $T_t = 2s$
 Temperature: $d = 20^\circ C$

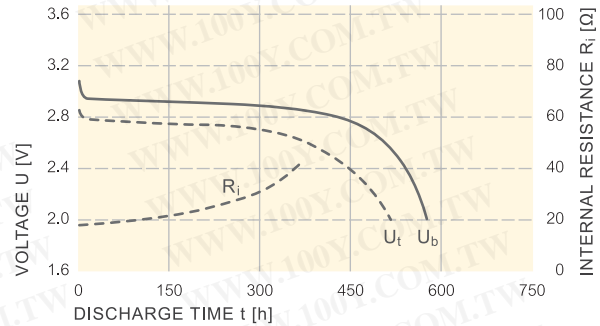

FIG. 39 – CR 2430

Load: cont. 5.6 kΩ (B)
 cont. 15 kΩ (B)
 cont. 270 kΩ (A)
 Mean discharge current: $I_1 = 400 \mu A$
 $I_2 = 180 \mu A$
 $I_3 = 10 \mu A$
 Temperature: $d = 20^\circ C$

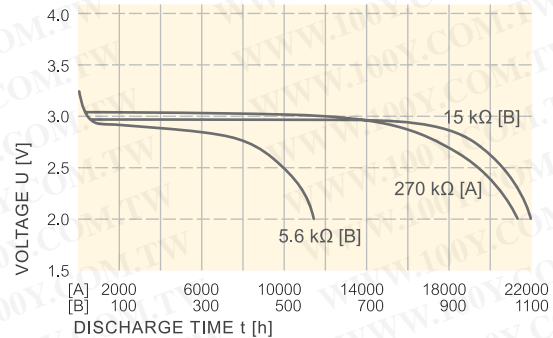

FIG. 40 – CR 2430

Discharge curves at different temperatures
 Load: cont. $R = 15 k\Omega$
 Mean discharge current at
 temperature: $d = 0^\circ C \sim 175 \mu A$
 $d = -10^\circ C \sim 170 \mu A$
 $d = -20^\circ C \sim 155 \mu A$

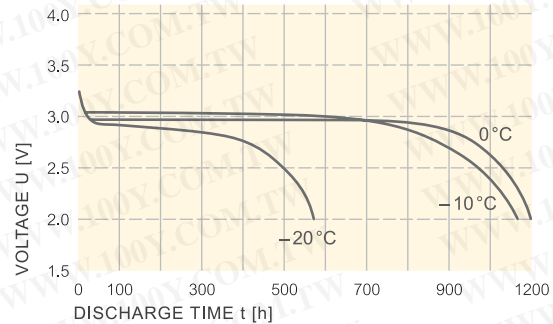
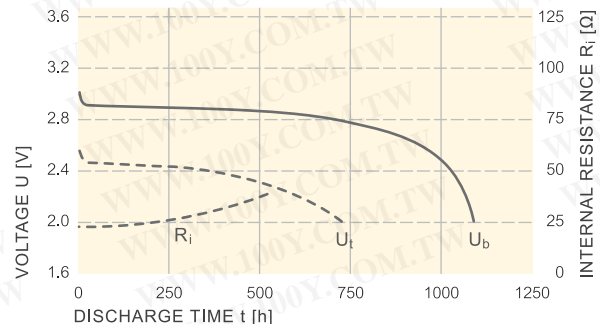

FIG. 41 – CR 2450

Load: cont. 5.6 kΩ: U_b
 Pulse: 2 s/2 h 100 Ω: U_t
 (parallel)
 Internal Resistance R_i calculated from
 U_b and U_t at $R_t = 100 \Omega$ and $T_t = 2s$
 Temperature: $d = 20^\circ C$



3. CR HIGH CAPACITY PRIMARY LITHIUM CYLINDRICAL CELLS



勝特力材料 886-3-5753170
勝特力电子(上海) 86-21-54151736
勝特力电子(深圳) 86-755-83298787
[Http://www.100y.com.tw](http://www.100y.com.tw)

勝特力材料 886-3-5753170
 勝特力电子(上海) 86-21-54151736
 勝特力电子(深圳) 86-755-83298787
[Http://www.100y.com.tw](http://www.100y.com.tw)

3.1 TYPES – TECHNICAL DATA



Type	Order No.	Nominal voltage (V)	Nominal capacity at 20°C, down to 2.0 V, load (mAh)	Max. continuous discharge current (mA)	Weight (g)
CR 1/2 AA	6127 101 301	3	950 mAh-5.6 kΩ	10	11.5
CR 2/3 AA	6237 101 301	3	1.350 mAh-1.0 kΩ	15	15.0
CR AA	6117 101 301	3	2.000 mAh-1.0 kΩ	20	21.5
CR 2/3 A	6238 101 301	3	1.350 mAh-1.0 kΩ	15	17.0

TABLE 6
 Technical data, CR High Capacity Primary Lithium Cylindrical Cells

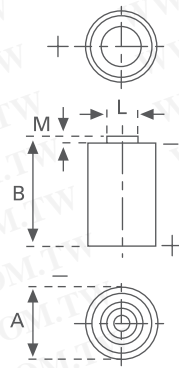

AFIG. 42

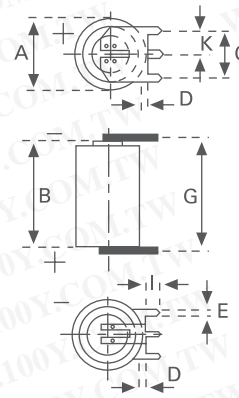

FIG. 43

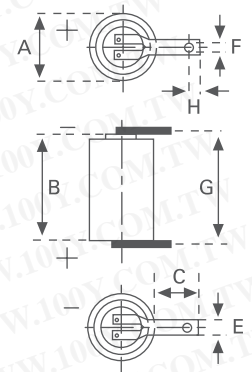

FIG. 44

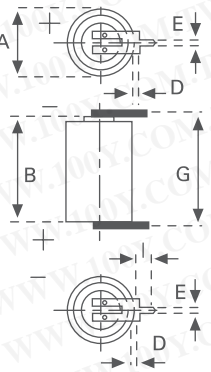
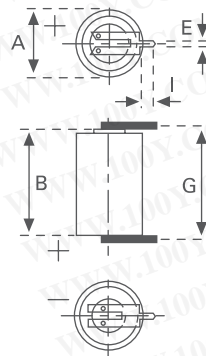

FIG. 45



AFIG. 46

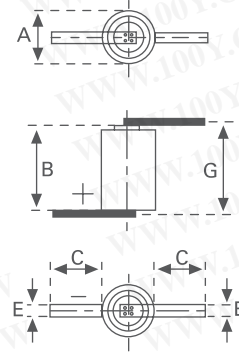

FIG. 47

勝特力材料 886-3-5753170
 勝特力电子(上海) 86-21-54151736
 勝特力电子(深圳) 86-755-83298787
 Http://www.100y.com.tw

3.2 ASSEMBLIES

Type	Order No.	A (Max.)	B	C	D	E	F	G	H	I	K	L	M	Fig. No.	Tags
CR 1/2 AA	6127 101 301	14.75	25.2	-	-	-	-	-	-	-	-	7.0	0.6	42	
CR 1/2 AA SLF	6127 201 301	14.75	25.2	10.0	1.0	1.0	-	25.4	-	3.0	5.0	-	-	43	
CR 1/2 AA LF	6127 301 301	14.75	25.2	10.0	-	3.5	2.1	25.4	2.5	-	-	-	-	44	
CR 1/2 AA CD	6127 501 301	14.75	25.4	45.0	-	-	-	-	-	-	-	-	-	49	
CR 1/2 AA CD	6127 601 301	14.75	25.4	-	7.5	-	-	33.5	-	-	-	-	-	48	(90°)
CR 1/2 AA SLF	6127 701 301	14.75	25.2	-	1.0	1.0	-	25.4	-	3.0	-	-	-	45	single pin
CR 1/2 AA LF	6127 801 301	14.75	25.2	14.5	-	3.0	-	25.4	-	-	-	-	-	47	(180°)
CR 1/2 AA SLF	6127 901 301	14.75	25.2	-	-	1.0	-	25.4	-	3.0	-	-	-	46	short pin
CR 1/2 AA TP	6127 601 381	14.75	25.2	16.5	-	0.64	-	25.8	-	-	-	-	-	50	terminal pin
CR 1/2 AA WC ¹⁾	6127 201 390	17.5	27.0	50.0	-	-	-	-	-	-	-	-	-	51	wire & connector
CR 2/3 AA	6237 101 301	14.75	33.5	-	-	-	-	-	-	-	-	7.0	0.6	42	
CR 2/3 AA SLF	6237 201 301	14.75	33.5	10.0	1.0	1.0	-	33.7	-	3.0	5.0	-	-	43	
CR 2/3 AA LF	6237 301 301	14.75	33.5	10.0	-	3.5	2.1	33.7	2.5	-	-	-	-	44	
CR 2/3 AA CD	6237 501 301	14.75	33.5	45.0	-	-	-	-	-	-	-	-	-	49	
CR 2/3 AA SLF	6237 701 301	14.75	33.5	-	1.0	1.0	-	33.7	-	3.0	-	-	-	45	single pin
CR 2/3 AA SLF	6237 901 301	14.75	33.5	-	-	1.0	-	33.7	-	3.0	-	-	-	46	short pin
CR AA	6117 101 301	14.75	50.0	-	-	-	-	-	-	-	-	7.0	0.6	42	
CR AA SLF	6117 201 301	14.75	50.0	10.0	1.0	1.0	-	50.2	-	3.0	5.0	-	-	43	
CR AA LF	6117 301 301	14.75	50.0	10.0	-	3.5	2.1	50.2	2.5	-	-	-	-	44	
CR AA CD	6117 501 301	14.75	50.2	45.0	-	3.5	-	-	-	-	-	-	-	49	
CR AA SLF	6117 701 301	14.75	50.0	-	1.0	1.0	-	50.2	-	3.0	-	-	-	45	single pin
CR AA WC ¹⁾	6117 201 390	18	51.0	50.0	-	-	-	-	-	-	-	-	-	51	wire & connector
CR 2/3 A	6238 101 301	17	33.5	-	-	-	-	-	-	-	-	7.0	0.6	42	
CR 2/3 A LF	6238 301 301	17	33.5	10.0	-	3.5	2.1	33.7	2.5	-	-	-	-	44	
CR 2/3 A CD	6238 501 301	17	33.5	45.0	-	-	-	-	-	-	-	-	-	49	

TAB. 7

Material: nickel plated sheet-steel, tag thickness: 0.15 mm till 0.25 mm. SLF: tip tinned, all types in green shrink sleeve.
¹⁾ using connector: JST type: PHR2 (Other connector types available on request.)
 Custom made assemblies are available on request for large volume.

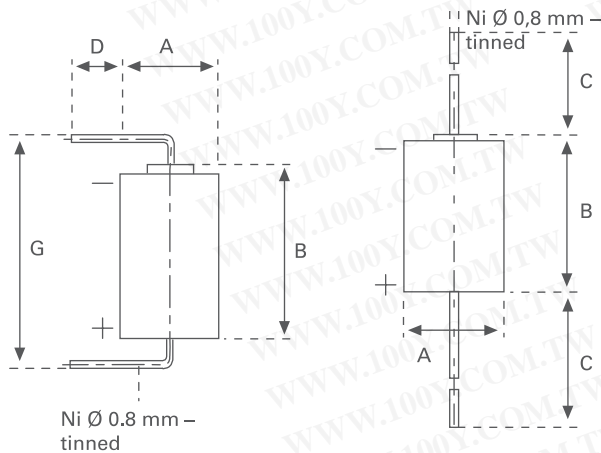

FIG. 48

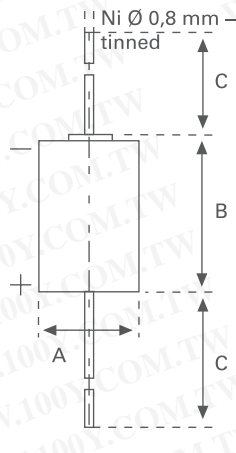

FIG. 49

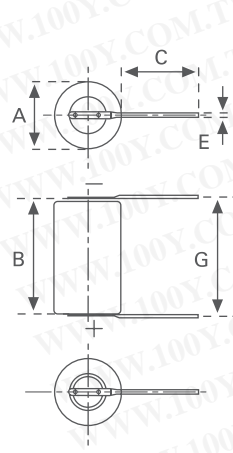

FIG. 50

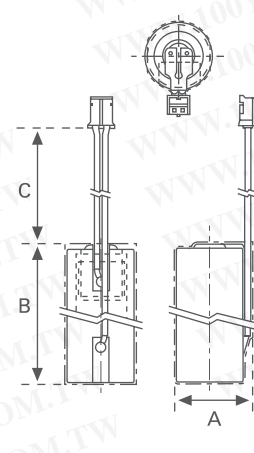

FIG. 51

3.3 PERFORMANCE DATA

勝特力材料 886-3-5753170
 勝特力电子(上海) 86-21-54151736
 勝特力电子(深圳) 86-755-83298787
[Http://www.100y.com.tw](http://www.100y.com.tw)

FIG. 52 – CR 1/2 AA
 FIG. 56 – CR 2/3 AA
 FIG. 60 – CR AA

Discharge characteristics at room temperature (21°C)

FIG. 52
CR 1/2 AA

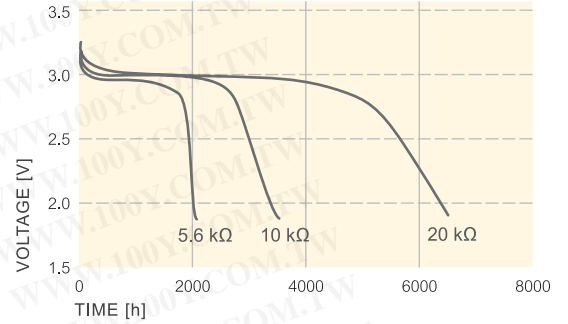

FIG. 53 – CR 1/2 AA
 FIG. 57 – CR 2/3 AA
 FIG. 61 – CR AA

Temperature characteristics at 5.6 kΩ

FIG. 53
CR 1/2 AA

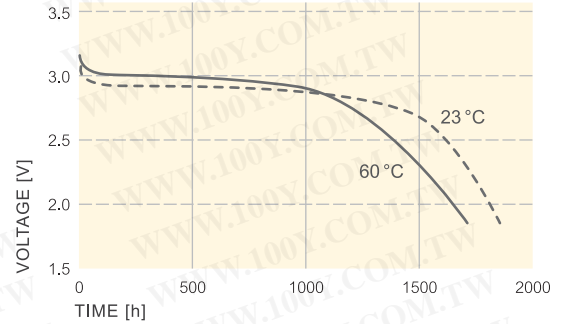

FIG. 54 – CR 1/2 AA
 FIG. 58 – CR 2/3 AA
 FIG. 62 – CR AA

Operating voltage vs. current drain, Voltage at 50% discharge

FIG. 54
CR 1/2 AA

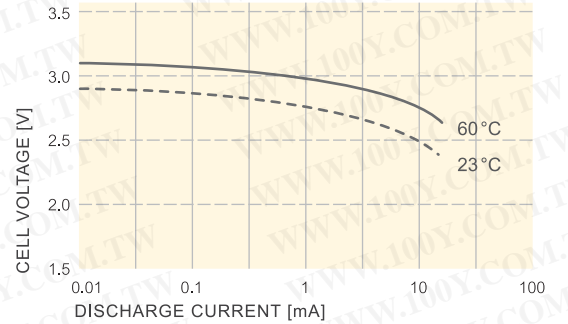
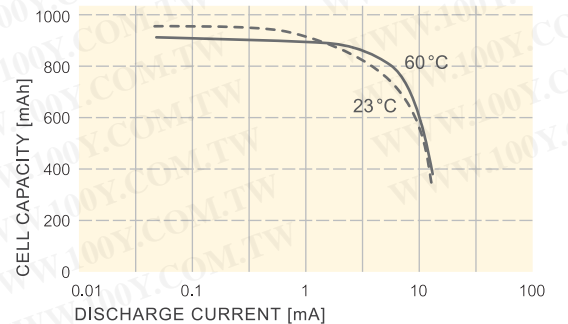

FIG. 55 – CR 1/2 AA
 FIG. 59 – CR 2/3 AA
 FIG. 63 – CR AA

Cell capacity vs. discharge current

FIG. 55
CR 1/2 AA



勝特力材料 886-3-5753170
 勝特力电子(上海) 86-21-54151736
 勝特力电子(深圳) 86-755-83298787
[Http://www.100y.com.tw](http://www.100y.com.tw)

FIG. 56
CR 2/3 AA

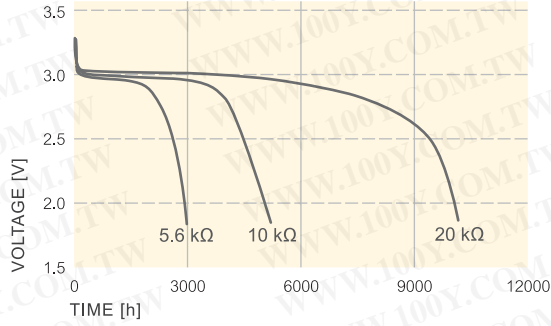

FIG. 60
CR AA

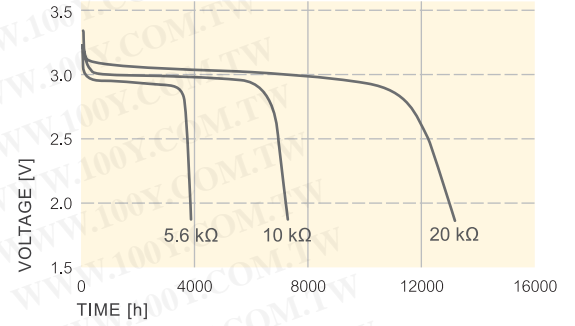

FIG. 57
CR 2/3 AA

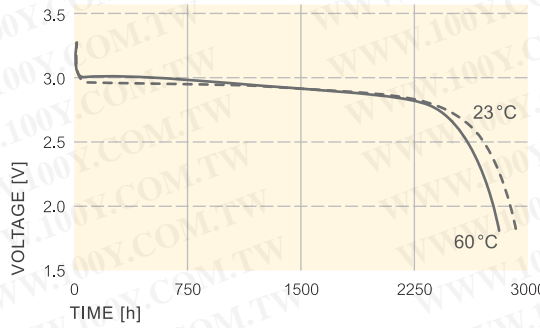

FIG. 61
CR AA

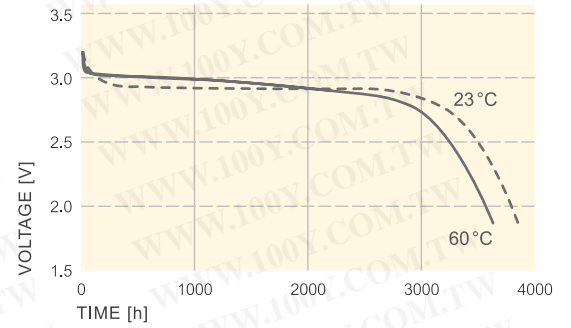

FIG. 58
CR 2/3 AA

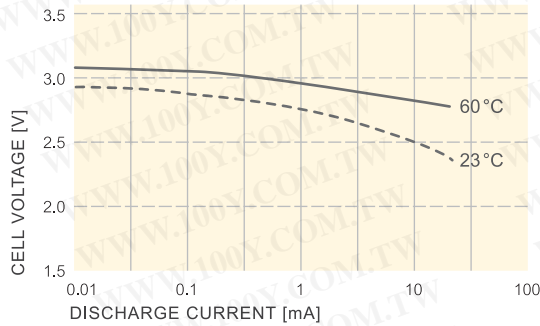

FIG. 62
CR AA

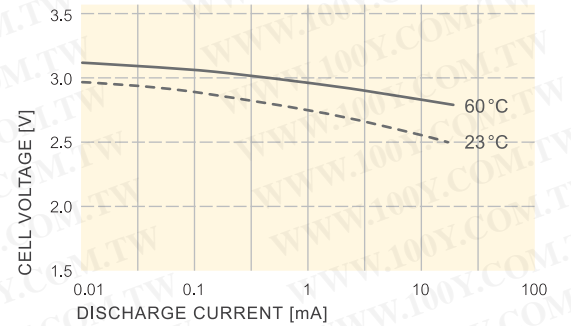

FIG. 59
CR 2/3 AA

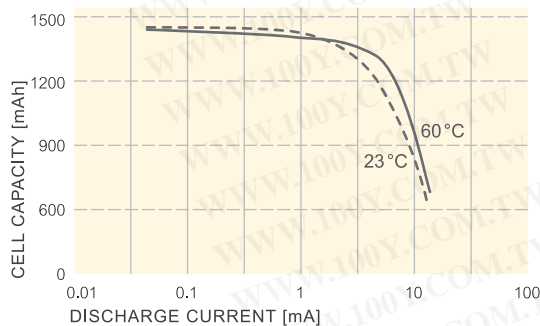
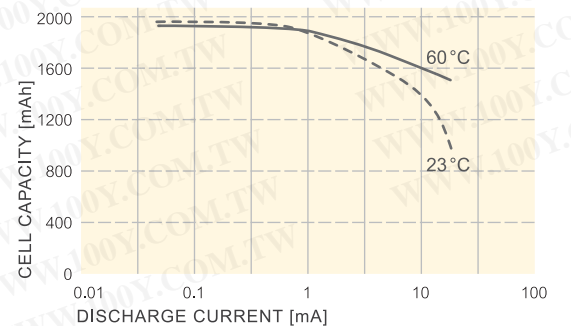

FIG. 63
CR AA



勝特力材料 886-3-5753170
 勝特力电子(上海) 86-21-54151736
 勝特力电子(深圳) 86-755-83298787
[Http://www.100y.com.tw](http://www.100y.com.tw)

FIG. 64 – CR 2/3 A
Discharge characteristics
at room temperature (21°C)

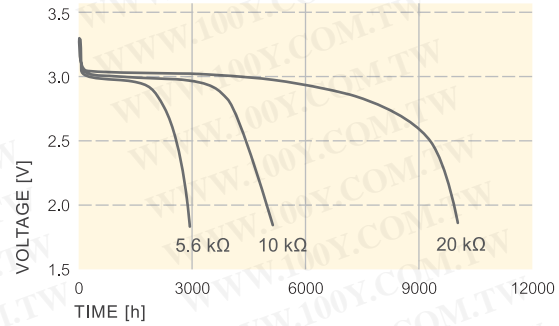

FIG. 65 – CR 2/3 A
Temperature characteristics
Constant load 5.6 kΩ

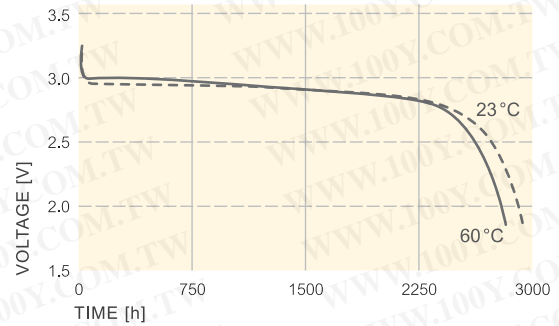

FIG. 66 – CR 2/3 A
Operating voltage vs. current drain
Voltage at 50% discharge

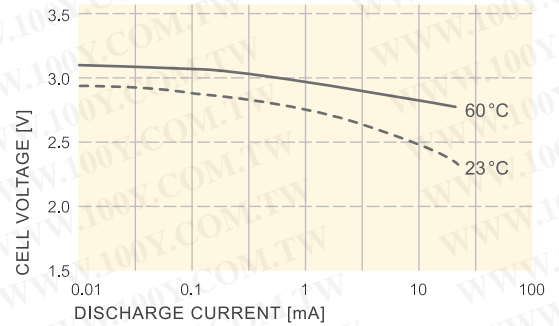
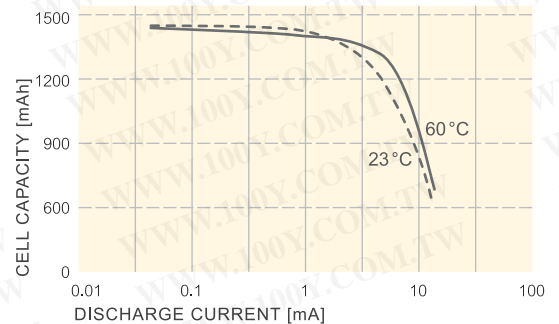

FIG. 67 – CR 2/3 A
Cell capacity vs. discharge current



4. CR HIGH POWER PRIMARY LITHIUM CYLINDRICAL CELLS



勝特力材料 886-3-5753170
勝特力电子(上海) 86-21-54151736
勝特力电子(深圳) 86-755-83298787
[Http://www.100y.com.tw](http://www.100y.com.tw)

4.1 TYPES – TECHNICAL DATA



CR 2/3 AH



CR 123 A



CR 2

勝特力材料 886-3-5753170
 勝特力电子(上海) 86-21-54151736
 勝特力电子(深圳) 86-755-83298787
[Http://www.100y.com.tw](http://www.100y.com.tw)

Type	Order No.	Nominal voltage (V)	Nominal capacity at 20 °C, load (mAh)	Max. continuous discharge current ¹⁾ (mA)	Weight (g)
CR 2/3 AH	6215 101 501	3	1500 mAh-200 Ω	1500	16
CR 123 A	6205 210 501	3	1500 mAh-200 Ω/2.0 V	1400	17
CR 2	6206 210 501	3	850 mAh-200 Ω/1.8 V	885	11

TAB. 8

Technical data, CR High Power Primary Lithium Cylindrical Cells

¹⁾ Current value for obtaining 50% capacity ²⁾ in blister card (1 pc)

4.2 ASSEMBLIES

Type	Order No.	A	B	C	D	E	F	G	H	I	K	L	M	Fig. No.	Tags
CR 2/3 AH	6215 101 501	17.0 ₋₁	33.9 _{-1.5}	-	-	-	-	-	-	-	-	6.3 ±0.2	1.0	68	-
CR 2/3 AH SLF	6215 201 013	16.5	33.3	10.0	-	1.0	-	33.7	-	3.0	-	-	-	70	-
CR 123 A	6205 210 501	17.0 ₋₁	34.5 _{-0.6}	-	-	-	-	-	-	-	-	6.4	1.29	68	-
CR 2	6206 210 501	15.6 _{-0.5}	27.0	-	-	-	-	-	-	-	-	6.5	0.7	68	-

TAB. 9

Material: nickel plated sheet-steel, tag thickness: 0.15 mm till 0.25 m. SLF: tip tinned.

Custom made assemblies are available on request for large volume.

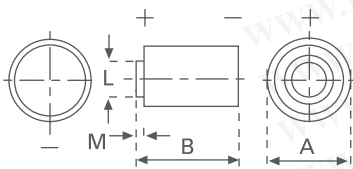

FIG. 68

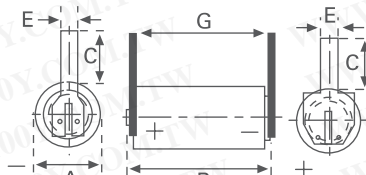

FIG. 69

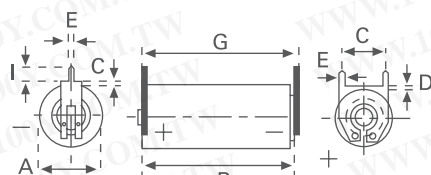

FIG. 70

4.3 PERFORMANCE DATA

FIG. 71 – CR 2/3 AH
 Discharge characteristics
 at room temperature (21°C)

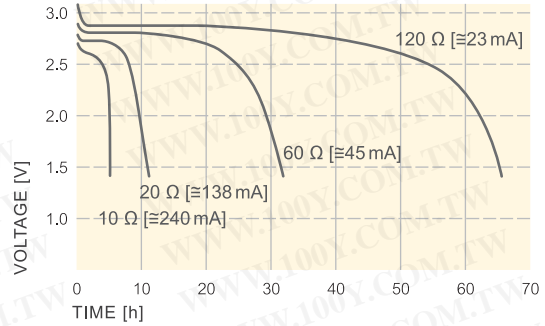

FIG. 72 – CR 2/3 AH
 Temperature characteristics
 Constant load 5.6 kΩ

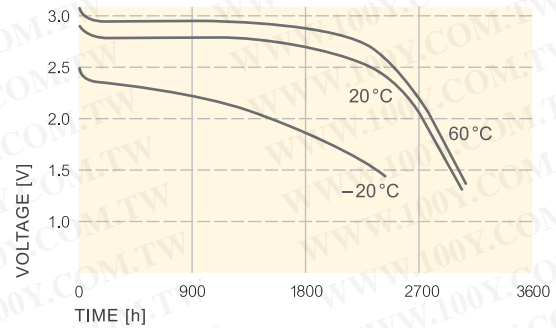

FIG. 73 – CR 2/3 AH
 Pulse discharge characteristics

¹⁾ Load: 0.9 A, 3 sec. on, 27 sec. off
²⁾ After storage at 60°C/100 days

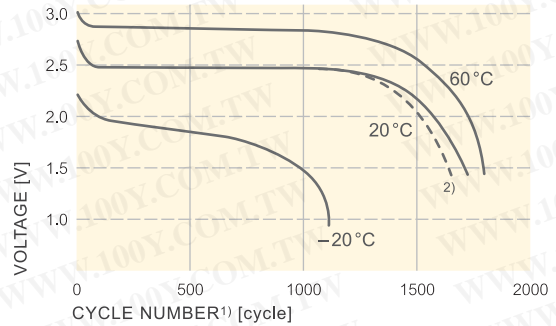
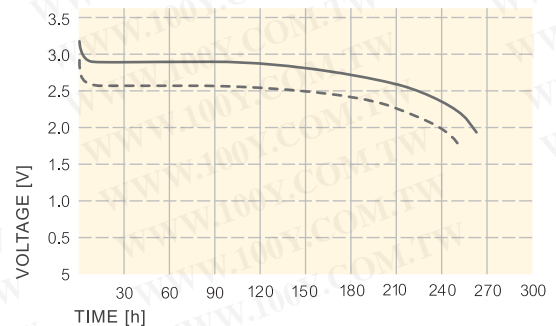

FIG. 74 – CR 2/3 AH
 Typical discharge curve
 Load: cont. 560 Ω
 Pulse load: 2 sec./min 3 Ω
 (parallel)



勝特力材料 886-3-5753170
 勝特力电子(上海) 86-21-54151736
 勝特力电子(深圳) 86-755-83298787
[Http://www.100y.com.tw](http://www.100y.com.tw)

FIG. 75 – CR 123 A
 Discharge characteristics
 at room temperature (21°C)

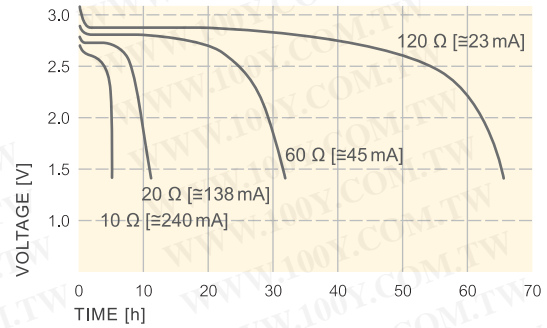

FIG. 76 – CR 123 A
 Temperature characteristics
 Constant load 5.6 kΩ

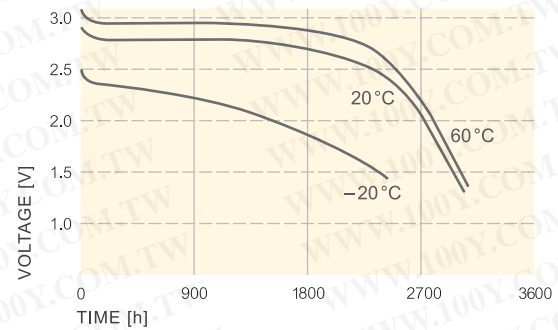

FIG. 77 – CR 123 A
 Pulse discharge characteristics

1) Load: 0.9 A, 3 sec. on, 27 sec. off
 2) After storage at 60°C/100 days

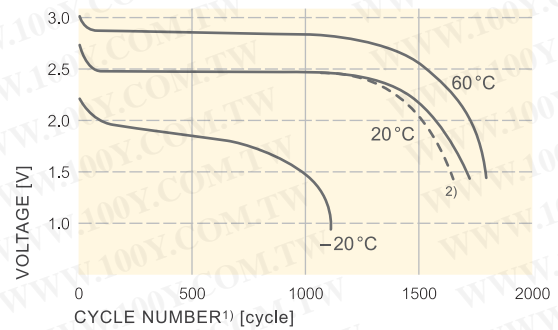

FIG. 78 – CR 123 A
 Typical discharge curve
 Load: cont. 560 Ω
 Pulse load: 2 sec./min 3 Ω
 (parallel)

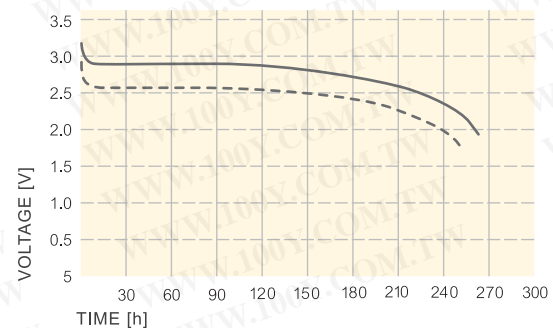

FIG. 79 – CR 2
 Discharge characteristics
 at room temperature (21°C)

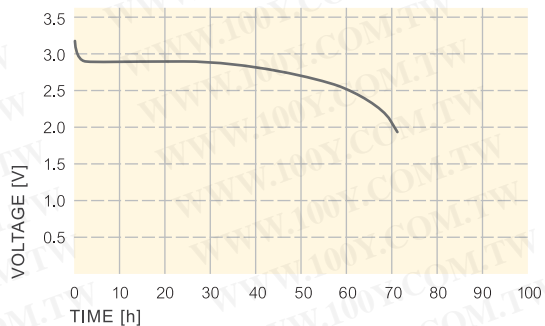

FIG. 80 – CR 2
 Pulse discharge characteristics

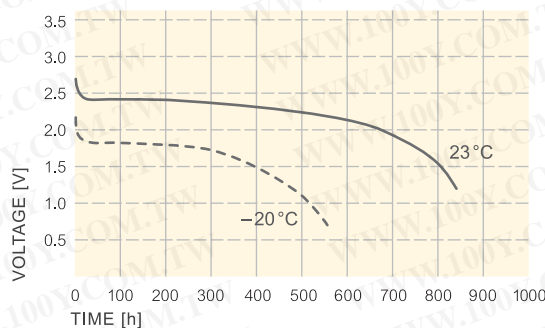
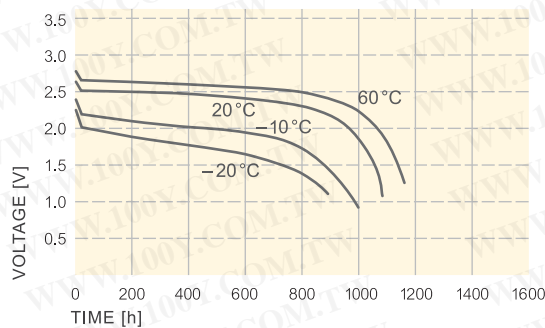

FIG. 81 – CR 2
 Discharge temperature characteristics



勝特力材料 886-3-5753170
勝特力电子(上海) 86-21-54151736
勝特力电子(深圳) 86-755-83298787
[Http://www.100y.com.tw](http://www.100y.com.tw)

5. GENERAL DESIGN CHARACTERISTICS

Battery Selection

In order to ensure optimum battery performance for the primary CR Button, the cylindrical CR High Power and cylindrical High Capacity cells, we suggest consideration of the following design-in requirements. They are the nominal and operating voltage, load current and profile,

the duty cycle, temperature requirements and shelf life for the application. These characteristics for each battery type must be evaluated against the design requirements to select the most appropriate product that fulfills these requirements.

Design-in Considerations

VARTA Microbattery Primary Lithium Batteries offer light-weight packaged power for a variety of portable electric and electronic equipment. They are suitable as a main or standby power source for memory (RAM) and Real-Time clock (RTC) applications.

The Lithium Batteries are blocked from the power supply by means of a diode to prevent discharge of the battery into the DC supply during shut down.

The voltage drop across D1 should be taken into account as the minimum voltage of the load that has to be maintained under all circumstances.

Blocking diode D2 and D3 prevents the battery from being charged through the power supply. The amount of accumulated reverse current (IR) should be kept around 1% of the cell's typical capacity during its standby life time.

A maximum of 5 μ A continuously must not be exceeded.

In the absence of a DC supply voltage, the lithium battery supplies the load with the necessary power.

As diodes fail at low current levels by an alloy-effect causing a severe reduction in impedance, an additional safety device must be incorporated.

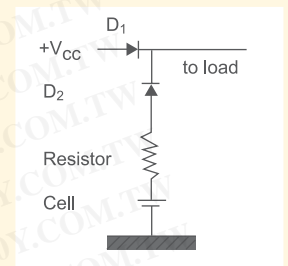

FIG. 76

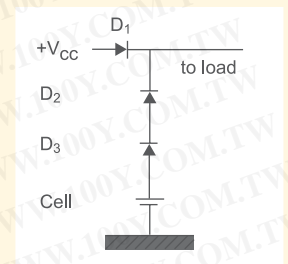

FIG. 77

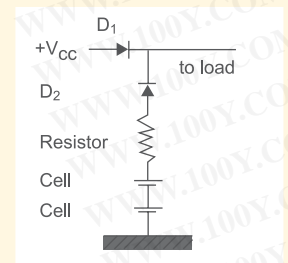

FIG. 78

Using 2 cells when 6 V is used in series

勝特力材料 886-3-5753170
勝特力电子(上海) 86-21-54151736
勝特力电子(深圳) 86-755-83298787
[Http://www.100y.com.tw](http://www.100y.com.tw)

勝特力材料 886-3-5753170
 勝特力电子(上海) 86-21-54151736
 勝特力电子(深圳) 86-755-83298787
[Http://www.100y.com.tw](http://www.100y.com.tw)

UL-Recognition

All **VARTA** Microbattery Lithium Cells and Batteries listed in Tab.10 are recognized by Underwriters Laboratories Inc. under UL-file number MH 13654 (N).

The cells are marked with the Recognized Component Mark.

Underwriters Laboratories requires for lithium cells/batteries a circuit, which must contain a protective component to prevent charging. In case of diode failure a current limiting resistor must be chosen according to the values listed in Tab. 10.

Please also pay attention to the Safety Guidelines on page 34.

For safety tests of the cells, "UL" requires either an additional diode, or a resistor, limiting the current to a safe level of 4 mA (for all cylindrical CR... A(A) lithium mass cells).

It should be noted that the value of the resistor has to be calculated using the higher power supply voltage – not the battery voltage.

The supply voltage to the load can be calculated by the battery voltage drop across the diode and the resistor.



Trademark of Underwriters
Laboratories

Button Cells		Cylindrical Cells	
Type	Max. safe reverse current acc. to UL	Type	Max. safe reverse current acc. to UL
CR 1216	3 mA	High Capacity	
CR 1220	3 mA	CR 1/2 AA	4 mA
CR 1616	4 mA	CR 2/3 AA	4 mA
CR 1620	2.5 mA	CR AA	4 mA
CR 2016	4 mA	CR 2/3 A	4 mA
CR 2025	5 mA		
CR 2032	5 mA	High Power	
CR 2320	5 mA	CR 2/3 AH	25 mA
CR 2430	15 mA	CR 123 A	10 mA
CR 2450	15 mA	CR 2	20 mA
CR 1/3 N	2 mA		

TAB. 10

All listed cells/batteries are recognized by UL-recognition.

Printed Circuit Board Mounting

Never solder on the body of the battery directly, use a battery equipped with PC-mount terminals. When using automatic soldering apply 250–270 °C within 5 seconds. Make sure that the battery is not suspended or dropped into the soldering bath.

Do not heat above 80 °C to avoid leakage caused by deterioration in the battery's performance.

勝特力材料 886-3-5753170
 勝特力电子(上海) 86-21-54151736
 勝特力电子(深圳) 86-755-83298787
[Http://www.100y.com.tw](http://www.100y.com.tw)

5.1 SAFETY TESTS

For safety aspects please consult Varta Microbattery before performing these extreme tests:

Compression Test 1120 kg

- no significant electrolyte loss
- no rupturing

In Short Circuit Condition 24 h, 0.1 Ω

- after 24 h the bottom of the cell is curved by only 0.1 mm; diameter unchanged
- no electrolyte creepage or loss
- no rupturing

Test at 150°C for 2 Hours

- no electrolyte creepage or loss
- no rupture
- no fire
- no explosion
- open circuit voltage almost unchanged at 3.2 V
- the cell base bowed, causing cell height to increase by 1 mm, diameter unchanged

Puncture Test total Penetration of the Cell by a Nail Ø 3mm

- no splashing or pressurized electrolyte loss
- no rupturing

Short Circuit

In table 11 the temperature is listed at short circuit at an ambient temperature of 20°C, 40°C and 70°C.

Ambient temperature	CR 1/2 AA	CR 2/3 AA	CR AA
20°C	24°C	28°C	24°C
40°C	50°C	50°C	47°C
70°C	80°C	84°C	77°C

TAB. 11

Vibration Test

Vibration test	Result
Frequency range 5 Hz → 55 Hz → 500 Hz → 55 Hz → 5 Hz	Without changing of the electrical values the following Li-cell can be exposed to this vibration test: ■ CR 1/2 AA ■ CR 2/3 AA ■ CR AA
Amplitude at frequency range: 5 to 55 Hz: ± 0.75 mm	
Acceleration at frequency range: 55 Hz to 500 Hz: 100 m/s ²	
Cycle duration: 15 min	
Oscillation time of each main axis: 3 h	

TAB. 12

Temperature Characteristics

FIG. 79

CR 1/2 AA, Temperature characteristics
 Conditions: 20 h/20°C: 15 kΩ,
 4 h/at various temp.: 270 kΩ

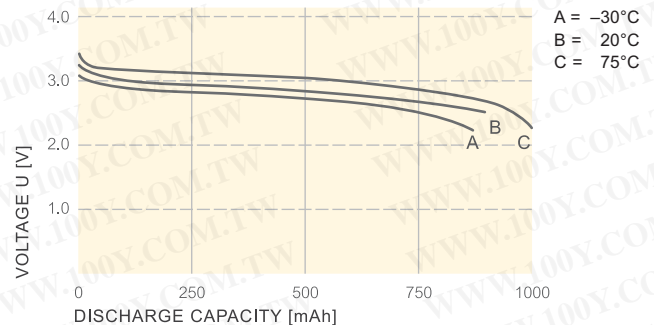

5.2 SAFETY GUIDELINES

Safety and Handling Issues

We recommend that attention begins to the design and implementation of our Lithium-Manganese Dioxide Button/Cylindrical Cells to ensure superior operating performance. With our Lithium-Manganese Dioxide Batteries, the appropriate precautions must be taken to avoid physical and electrical abuse, otherwise the batteries can be hazardous if not used properly. To avoid such incidents, we would suggest you review the following safety and handling precautions for your potential application:

- **Do not heat. Nor dispose of in fire**
If heated, the plastic materials in the cell such as the gasket and separator may be damaged, causing leakage. The heat generated by a short circuit inside the batteries may lead to bursting or combustion. If disposed of in fire, batteries may violently rupture.
- **Do not charge (Lithium Primary Battery CR Series)**
When a Lithium Primary Battery is charged, gas is generated inside the battery and can result in swelling, heat generation, leakage, violent rupture or potential fire.
- **Avoid forced discharge**
When batteries are force-over discharged with an external power source, the voltage drops to under 0.0 V (reverse electrode), and inner gas is generated. This can lead to swelling, heating, leakage, violent rupture and/or potential fire.
- **Do not short circuit**
If the positive and negative terminals come into contact with each other or with a metal object, this can cause a short circuit, generating heat. If the batteries are stacked on top of each other or mixed, the resulting short-circuit can lead to heat generation, leakage, violent rupture or fire.
- **Do not disassemble, apply excessive pressure or deform**
If a battery is forcefully disassembled, gas may be generated which may cause throat irritation, or the lithium metal may generate heat, causing fire. If deformed under pressure or under impact, distortion of the seal may lead to leakage, or a short circuit inside the battery may lead to potential safety hazards.
- **Do not use with other battery types or old batteries with fresh cells**
If different types of batteries are used together, or fresh are used with old ones, the difference in characteristics of voltage, capacity, etc. may cause overdischarge of the battery which is exhausted first, leading to swelling, bursting or fire.

勝特力材料 886-3-5753170
勝特力电子(上海) 86-21-54151736
勝特力电子(深圳) 86-755-83298787
[Http://www.100y.com.tw](http://www.100y.com.tw)

- **Observe the (+) and (-) polarity**

If the batteries cell polarity is reversed by inserting the battery backwards, depending on the equipment, a short circuit or over discharging may result in a potential safety hazard.

- **Do not swallow**

Store batteries in a safe location, out of the reach of babies and small children. Also, make sure that batteries cannot be easily removed from equipment in which they are used. If swallowed by mistake, consult a doctor immediately.

- **Do not store in direct sunlight or rain**

Store batteries in a place not subject to direct sunlight. Make sure the area is dry and is approximately 20°C. Storage in areas with higher temperature, humidity or exposure to rain may cause deterioration in battery quality and durability.

- **Soldering**

Do not solder or weld directly to the cell's surface. Use preassembled cells with tabs or leads.

- **Do not throw into water**

This can result in corrosion and the generation of combustible gas.

勝特力材料 886-3-5753170
勝特力电子(上海) 86-21-54151736
勝特力电子(深圳) 86-755-83298787
[Http://www.100y.com.tw](http://www.100y.com.tw)

5.3 TRANSPORTATION OF VARTA MICROBATTERY LITHIUM CELLS AND BATTERIES

In general, Lithium batteries are subjected to transport regulations depending on the means of transportation. But all batteries sold by VARTA Microbattery which are listed in this handbook are not subjected to the transport regulations of dangerous goods*, because they fulfil the following requirements (Special provisions ADR 188, IATA 45, IMDG 188, DOT / 49 CFR 173.185):

- The batteries do not contain more than 1 g of Lithium per cell respectively 2 g Lithium per battery.
- The batteries passed the safety tests according to clause 38.3 of the UN handbook of tests and criteria.
- The batteries are isolated in the packaging to avoid short circuits.
- The packs are marked with a warning notice that clearly states that the pack contains Lithium batteries and must be quarantined, inspected and repacked if damaged.
- The total mass must not exceed 30 kg per pack.

*Transportation of primary Lithium Batteries in the USA

Effective December 29, 2004, the U.S. Department of Transport requires that the outside of each package that contains primary lithium batteries, regardless of size or number of batteries, is to be labeled with the following statement: "PRIMARY LITHIUM BATTERIES – FORBIDDEN FOR TRANSPORT ABOARD PASSENGER AIRCRAFT". The labeling requirement covers shipments via highway, rail, vessel or cargo-only aircraft and covers all shipments inside, into or out of the US. The label must be in contrasting color and the letters must be 12 mm (0.5 in) in height for packages weighing more than 30 kg and 6 mm (0.25 in) in height for packages weighing less than 30 kg.

General remark

The exemptions from dangerous goods regulations are only applicable with respect to the delivery form/packaging in which the lithium batteries are dispatched by VARTA Microbattery. Any re-packaging or assembly of cells is in the responsibility of the customer and makes new safety tests necessary. Note that the maximum amount of lithium or lithium-equivalent according to special provisions 188 (ADR) or A45 (IATA) may be exceeded as a consequence of assembly. Used lithium batteries have to be handled like fresh ones.

We do not recommend to weld terminals to the batteries; this should only be done by qualified personnel.

勝特力材料 886-3-5753170
 勝特力电子(上海) 86-21-54151736
 勝特力电子(深圳) 86-755-83298787
[Http://www.100y.com.tw](http://www.100y.com.tw)