

## WP5-12 12Volt 5Ah

### Specifications

Nominal Voltage(V) **12V**

#### Nominal Capacity

20 hour rate	(0.25A to 10.50V)	<b>5Ah</b>
10 hour rate	(0.475A to 10.50V)	<b>4.75Ah</b>
5 hour rate	(0.85A to 10.20V)	<b>4.25Ah</b>
1 C	(5A to 9.60V)	<b>2.833Ah</b>
3 C	(15A to 9.60V)	<b>2.0Ah</b>

Weight **Approx. 1.9kg(4.18Lbs.)**

Internal Resistance (at 1KHz) **Approx. 19 mΩ**

#### Maximum Discharge Current for

5 seconds: **75A**

#### Charging Methods at 25 (77 )

Cycle use:

Charging Voltage **14.4 to 15.0V**

Coefficient -5.0mv/ /cell

Maximum Charging Current : **1.5A**

Standby use:

Float Charging Voltage **13.50 to 13.80V**

Coefficient -3.0mv/ /cell

#### Operating Temperature Range

Charge **-15 (5 ) to 40 (104 )**

Discharge **-15 (5 ) to 50 (122 )**

Storage **-15 (5 ) to 40 (104 )**

#### Charge Retention (shelf life) at 20 (68 )

1 month **92%**

3 month **90%**

6 month **80%**

Case Material **ABS**

(Option: UL94 HB & UL94 V-0 flame retardant )

Terminal **F1 or F2 (Faston Tab 187 or 250)**



### Dimensions

mm(inch)

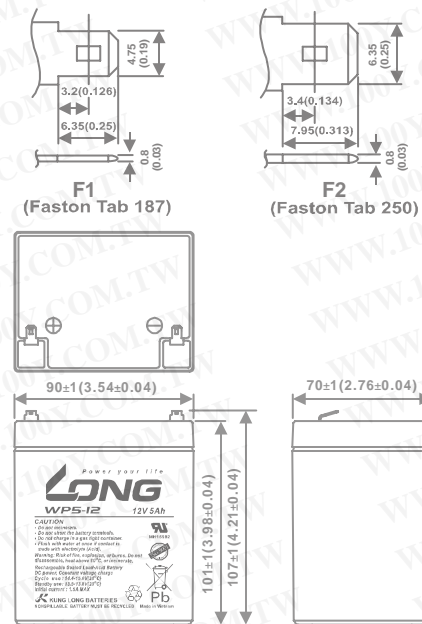

(v) FOR 12V BATTERY Discharge Time VS. Discharge Current (25 )

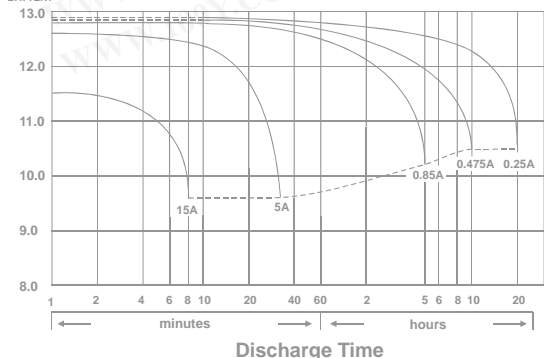

Effect of Temperature on Capacity 25• (77• )

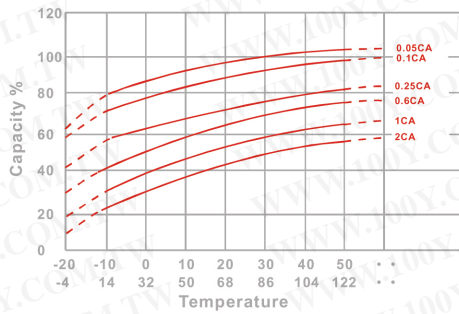

Capacity Retention Characteristic

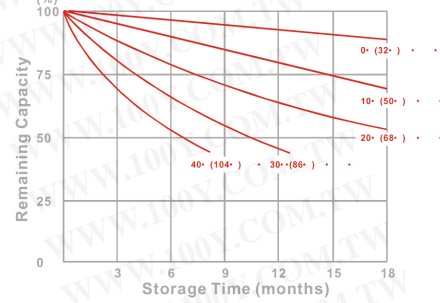

Trickle (or float) Service Life

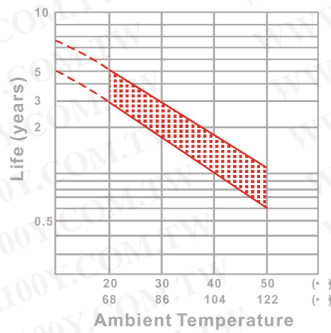

Cycle Service Life

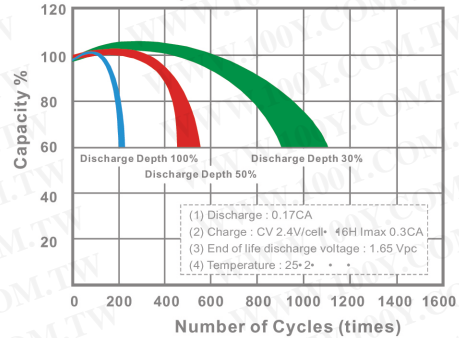

**- PERFORMANCE DATA**

Discharge Rates in Watts to Various End Voltages at 25• (77• )

End Voltage		1.85V	1.80V	1.75V	1.70V	1.67V	1.65V	1.60V
Time								
5	min	218	237	249	261	266	273	282
10	min	154	166	175	181	184	188	194
15	min	118	127	131	135	137	139	142
30	min	66.9	70.3	72.7	75.1	75.9	76.8	77.5
60	min	35.7	37.6	38.8	40.2	40.9	41.6	42.4
120	min	18.8	20.3	21.2	21.9	22.3	22.8	23.5
180	min	15.2	16.3	17.1	17.8	18.1	18.4	18.9
240	min	12.1	12.9	13.6	14.0	14.2	14.4	14.7
300	min	10.4	11.2	11.7	11.9	12.0	12.1	12.3
600	min	6.05	6.53	6.89	7.02	7.08	7.14	7.23
1200	min	3.18	3.43	3.62	3.69	3.72	3.75	3.80

- Discharge Rates in Amperes to Various End Voltages at 25• (77• )

End Voltage		1.85V	1.80V	1.75V	1.70V	1.67V	1.65V	1.60V
Time								
5	min	17.8	21.7	23.9	25.8	26.4	27.0	27.8
10	min	13.2	14.8	15.7	16.2	16.6	16.9	17.3
15	min	9.92	10.5	10.9	11.1	11.2	11.3	11.5
30	min	5.84	6.15	6.26	6.38	6.42	6.47	6.55
60	min	3.04	3.20	3.38	3.46	3.49	3.53	3.59
120	min	1.58	1.70	1.79	1.87	1.91	1.94	1.99
180	min	1.27	1.35	1.41	1.47	1.49	1.52	1.55
240	min	1.00	1.07	1.11	1.15	1.16	1.18	1.21
300	min	0.851	0.898	0.919	0.942	0.953	0.962	0.978
600	min	0.497	0.506	0.514	0.521	0.524	0.529	0.535
1200	min	0.268	0.274	0.279	0.284	0.286	0.287	0.291

All data on the spec. sheet is an average value:

The tolerance range : X<6min(+15%~-15%), 6min• X<10min(+12%~-12%), 10min• X < 60min(+8%~-8%), X• 60min(+5%~-5%)

260412 1E

勝特力材料 886-3-5753170  
 勝特力电子(上海) 86-21-34970699  
 勝特力电子(深圳) 86-755-83298787  
[Http://www.100y.com.tw](http://www.100y.com.tw)