



勝特力材料 886-3-5753170
 勝特力电子(上海) 86-21-54151736
 勝特力电子(深圳) 86-755-83298787
[Http://www.100y.com.tw](http://www.100y.com.tw)



HR 1234W F2

12V 34W

HR 1234W F2 is specially designed for high efficient discharge application. Its characteristics are small volume, light weight and high discharge efficiency. It can be used for more than 260 cycles at 100% discharge in cycle service, or three to five years in standby service.

Specification

Cells Per Unit	6
Voltage Per Unit	12
Capacity	34W @ 15minute-rate to 1.67V per cell @25 °C(77°F)
Weight	Approx. 2.60kg(5.73 lbs)
Maximum Discharge Current	130A(5sec)
Internal Resistance	Approx. 20mΩ
Operating Temperature Range	Discharge: -20°C~50°C(-4°F~122°F) Charge: 0°C~40°C(32°F~104°F) Storage: -20°C~40°C(-4°F~104°F)
Nominal Operating Temperature Range	25°C±3°C(77°F±5°F)
Float Charging Voltage	13.5 to 13.8 VDC/unit Average at 25°C(77°F)
Recommended Maximum Charging Current Limit	3.4A
Equalization and Cycle Service	14.4 to 15.0 VDC/unit Average at 25°C(77°F)
Self Discharge	CSB Batteries can be stored for more than 6 months at 25°C(77°F). Please charge batteries before using. For higher temperatures the time interval will be shorter.
Terminal	Faston Tab 250
Container Material	-ABS (UL94-HB)*Flammability resistance of UL94-V2 can be available upon request.



CSB-manufactured batteries are UL-recognized components under UL924 as well as ISO 9001 and ISO 14001 certified.

Dimensions

unit: (MM)

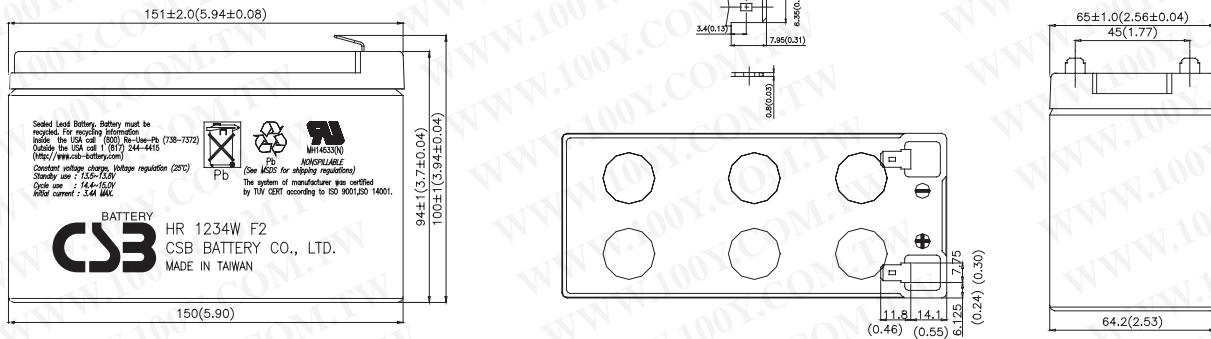

Constant Current Discharge Characteristics Unit:A (25°C, 77°F)

F.V/Time	2MIN	4MIN	6MIN	8MIN	10MIN	15MIN	20MIN	30MIN	60MIN	90MIN
1.60V	60.2	44.9	35.0	29.9	25.8	19.0	15.0	10.8	5.83	4.67
1.67V	56.1	42.0	32.7	28.3	24.4	18.2	14.1	10.4	5.61	4.48
1.70V	54.3	40.8	31.7	27.7	23.8	17.8	13.8	10.3	5.52	4.40
1.75V	51.5	38.6	30.6	26.6	22.6	17.2	13.5	10.1	5.50	4.35
1.80V	48.7	36.5	29.6	25.6	21.4	16.6	13.3	9.92	5.47	4.30
1.85V	45.8	34.4	28.5	24.5	20.3	16.0	13.1	9.76	5.45	4.25

Constant Power Discharge Characteristics Unit:W (25°C, 77°F)

F.V/Time	2MIN	4MIN	6MIN	8MIN	10MIN	15MIN	20MIN	30MIN	60MIN	90MIN
1.60V	722	539	420	359	309	228	180	130	70.0	56.0
1.67V	673	504	392	340	292	218	170	125	67.3	53.8
1.70V	652	489	380	332	285	214	165	123	66.2	52.8
1.75V	618	464	368	320	271	207	163	121	65.9	52.2
1.80V	584	438	355	307	257	199	160	119	65.6	51.6
1.85V	550	413	343	295	243	192	158	117	65.3	51.0

- All mentioned values are average values.
- Low rate discharge mode (over 90 mins.) is not recommended.

Trickle (or Float) Service Life

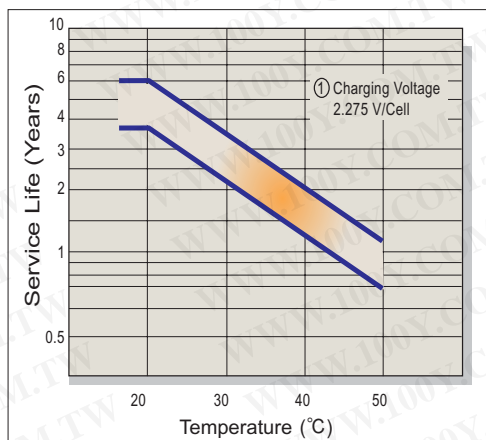

Capacity Retention Characteristic

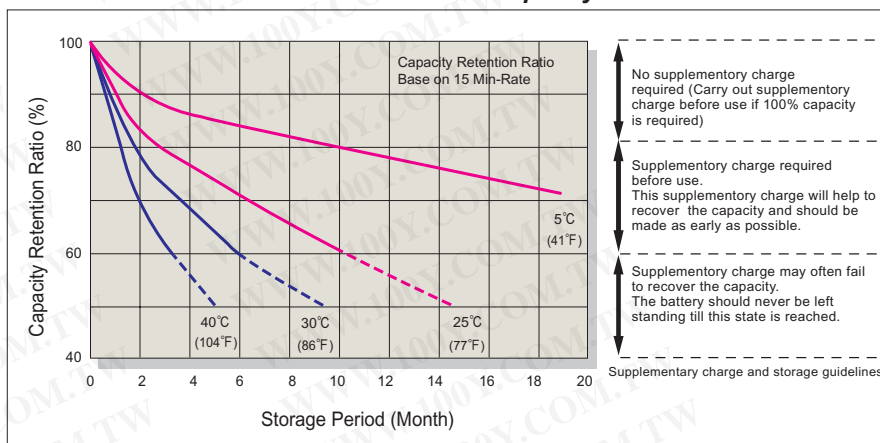

Battery Voltage and Charge Time for Standby Use

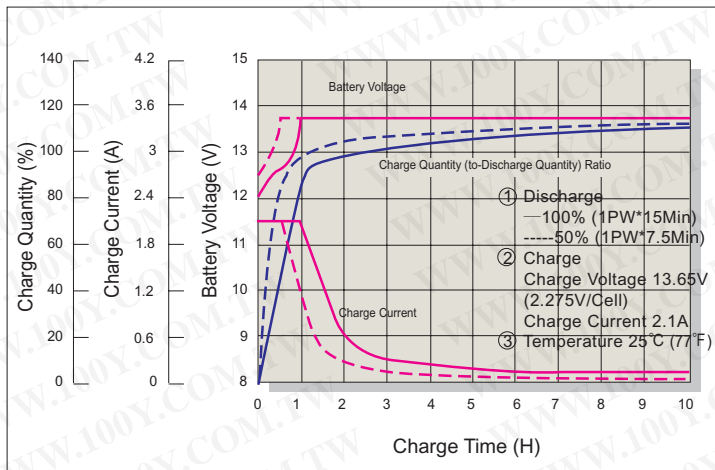

Cycle Service Life

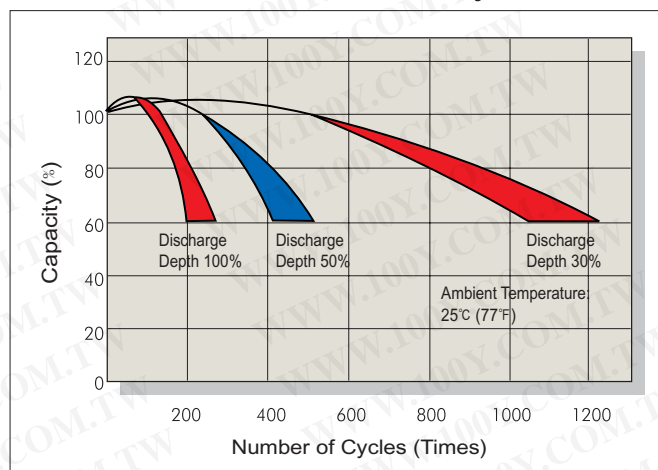

Battery Voltage and Charge Time for Cycle Use

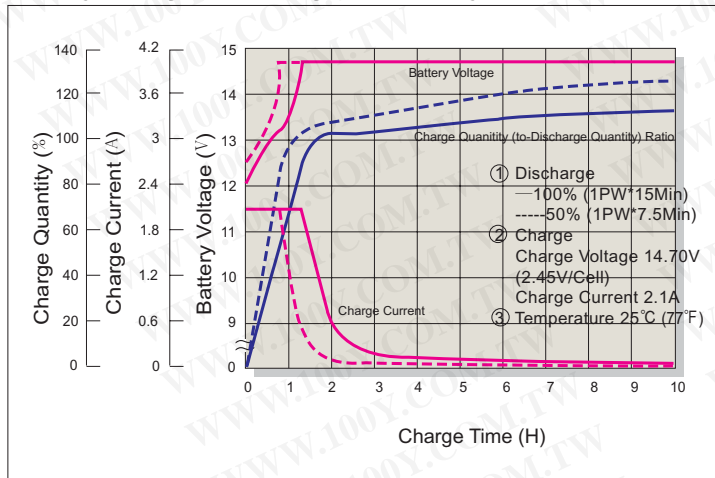

Terminal Voltage (V) and Discharge Time (25°C 77°F)

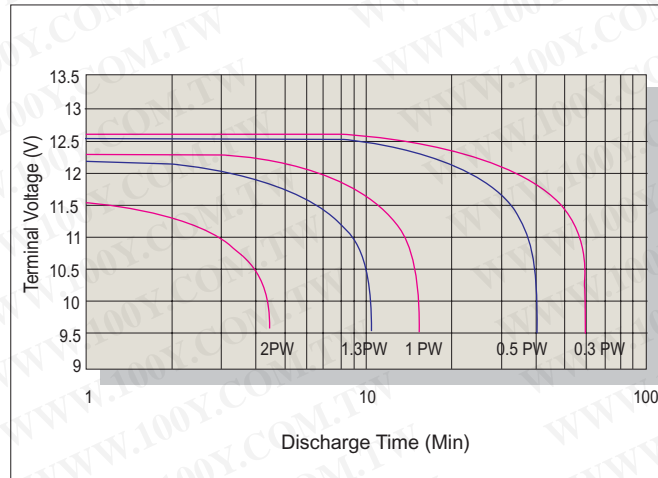

Charging Procedures

Application	Charge Voltage (V/Cell)			Max. Charge Current
	Temperature	Set Point	Allowable Range	
Cycle Use	25°C (77°F)	2.45	2.40~2.50	0.3C
Standby	25°C (77°F)	2.275	2.25~2.30	

Discharge Current VS. Discharge Voltage

Final Discharge Voltage V/Cell	1.75	1.70	1.55	1.30
Discharge Current (A)	0.2C > (A)	0.2C < (A) < 0.5C	0.5C < (A) < 1.0C	(A) > 1.0C

CSB BATTERY CO., LTD.
GLOBAL HEADQUARTERS
 10F1, No. 301, Sec. 2, Tiding Blv.,
 Nei-Hu, Taipei 114, Taiwan, R.O.C.
 Tel : 886-2-87515000
 Fax: 886-2-87516161
 E-mail: service@csb-battery.com.tw
 URL: www.csb-battery.com

CSB BATTERY TECHNOLOGIES, INC.
NORTH AMERICA HEADQUARTERS
 Tel : 1-619-710-0188
 Fax: 1-619-710-0189
FORT WORTH SALES OFFICE
 Tel : 1-817-244-7777/(800)3-CSB-USA
 Fax: 1-817-244-4445
 E-mail: csb@csb-battery.com

CSB BATTERY LOGISTICS
(SHANGHAI), CO., LTD.
 Tel : 86-21-5046-1622, 504
 Fax: 86-21-5046-3314
BEIJING OFFICE
 Tel : 86-10-6597-8060, 659
 Fax: 86-10-6597-8050
 E-mail: chinasl@csb-batte

勝特力材料 886-3-5753170
 勝特力电子(上海) 86-21-54151736
 勝特力电子(深圳) 86-755-83298787
 Http://www.100y.com.tw