

文件名称 File Name	文件编号 DOC NO	客户代码 Code	版本	日期 Date	产品类别 Product category	页码
产品规格书	FUXY/SPC-00260		1.0	2019/01/04	聚合物锂离子充电电池	3/13

Content

目录

1. Scope	4
适用范围	
2. Model: FUXY102050	4
编码规则	
3. Dimensions of cell	4
电芯尺寸	
4. Specification battery pack	5
电池规格	
5. Specification of cell	6
电芯规格	
6. Battery Cell Performance Criteria	6
电池性能检查及测试	
7. Required Protection Functions	9
保护功能要求	
8. Storage and Others	13
贮存及其它事项	

勝特力材料 886-3-5753170
 勝特力电子(上海) 86-21-34970699
 勝特力电子(深圳) 86-755-83298787
[Http://www.100y.com.tw](http://www.100y.com.tw)

文件名称 File Name	文件编号 DOC NO	客户代码 Code	版本 版本	日期 Date	产品类别 Product category	页码
产品规格书	FUXY/SPC-00260		1.0	2019/01/04	聚合物锂离子充电电池	4/13

1. Apply for Scope

适用范围

This specification describes the function of chargeable Li-ion polymer battery that made in Shenzhen Fuxinyuan Energy Technology Co.,Ltd

本规格说明书描述了深圳市福新能源科技有限公司生产的可充电锂聚合物电池产品性能指标。

2.Model: FUXY102050

电池规格: FUXY102050

3. Dimensions of cell

电芯尺寸

≤T: 10.2mm * W:20.5mm * L: 50.5mm

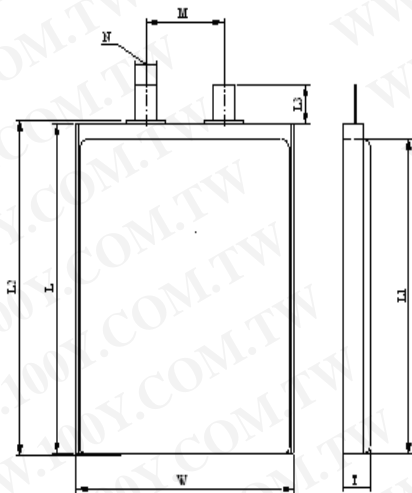

文件名称 File Name	文件编号 DOC NO	客户代码 Code	版本	日期 Date	产品类别 Product category	页码
产品规格书	FUXY/SPC-00260		1.0	2019/01/04	聚合物锂离子充电电池	5/13

4. Specification battery pack

电池规格

	Item	Specifications	Comments
4.1	Capacity (容量)	1000mAh	
4.2	Impedance (内阻)	$\leq 200\text{m}\Omega$	
4.3	Dimensions (mm) (尺寸)	10.0 (T) *20.0 (W) *50.0(mm)	
4.4	Weight (g) (重量)	约 17.4g	
4.5	Max. charge voltage (最大充电电压)	4.2V	
4.6	Max. charge current (最大充电电流)	1.0CmA	
4.7	Discharge cut-off voltage (放电截止电压)	2.45V	
4.8	Max discharge current (最大放电电流)	1.0CmA	
4.9	Charge temperature (充电温度)	0°C ~ +45°C	
4.10	Discharge temperature (放电温度)	-20°C ~ +60°C	
4.11	Storage temperature (储存温度)	-20°C ~ +35°C	
4.12	Storage humidity (储存湿度)	< 85%	

文件名称 File Name	文件编号 DOC NO	客户代码 Code	版本	日期 Date	产品类别 Product category	页码
产品规格书	FUXY/SPC-00260		1.0	2019/01/04	聚合物锂离子充电电池	6/13

5.Specification of cell

电芯规格

NO.	Items	Specifications
1	Charge voltage 充电电压	4.2V
2	Nominal voltage 标称电压	3.7V
3	Nominal capacity 标称容量	1000mAh 0.2C Discharge(0.2C 放电)
4	Charge current 充电电流	Standard Charging:: 0.5C 标准充电: 0.5C Rapid charge: 1.0C 快速充电: 1.0C
5	Standard Charging method 标准充电方法	0.5C CC (constant current) charge to 4.2V, then CV(constant voltage 4.2V)charge till charge current decline to $\leq 0.02C$ 0.5C CC (恒流) 充电至 4.2V, 再 CV (恒压 4.2V) 充电直至充电电流 $\leq 0.02C$
6	Charging time 充电时间	Standard Charging: 5.0hours(Ref.) 标准充电: 5.0 小时 (参考值) Rapid charge: 2hours(Ref.) 快速充电: 2 小时 (参考值)
7	Max.charge current 最大充电电流	1.0C
8	Max.discharge current 最大放电电流	1.0C
9	Discharge cut-off voltage 放电截止电压	3.0V
10	Operating temperature 工作温度	Charging: 0°C~45°C 充电: 0°C~45°C Discharging: -20°C~60°C 放电: -20°C~60°C
11	Storage temperature 储存温度	-10°C~+35°C
12	Cell Weight 电芯重量	Approx: 16.2g 约: 16.2g

6.Battery Cell Performance Criteria

电芯性能检查及测试

6.1 Electrical characteristics 充放电性能

文件名称 File Name	文件编号 DOC NO	客户代码 Code	版本	日期 Date	产品类别 Product category	页码
产品规格书	FUXY/SPC-00260		1.0	2019/01/04	聚合物锂离子充电电池	7/13

NO.	Items	Test Method and Condition	Criteria
1	Standard Charge 标准充电	Charging the cell initially with constant current at 0.2C and then with constant voltage at 4.2V till charge current declines to 0.02C 先用 0.5C 恒流充电至 4.2V，再恒压 4.2V 充电直至充电电流 $\leq 0.02C$	
2	Rated Capacity 初始容量	The capacity means the discharge capacity of the cell, which is measured with discharge current of 0.2C with 3.0V cut-off voltage after standard charge. 该容量是指标准充电后，0.2C 放电至 3.0V 截止电压所放出的容量。	$\geq 1000\text{mAh}$
3	Cycle Life 循环寿命	Test condition: Charge: 0.5C to 4.2V Discharge: 0.2 C to 3.0V 80% or more of 1 st cycle capacity at 0.2C discharge of Operation 测试条件: 充电: 0.5C 充电到 4.2V 放电: 0.2C 放电到 3.0V 当放电容量降至初始容量的 80% 时，所完成的循环次数定义为该电芯的循环寿命	≥ 300 次
4	Self-discharge 自放电	After charging standard, in $20 \pm 5^\circ\text{C}$ conditions storage 28 days, again with 0.2 C discharge to 3.0 V emit capacity. 标准充电后，在 $20 \pm 5^\circ\text{C}$ 条件下贮存 28 天，再以 0.2C 放电至 3.0V 所放出的容量。	Residual capacity >95 % 余容量 >95%
5	Initial impedance of cell 电池初始内阻	Internal resistance measured at AC 1KHz after 50% charge 半充状态下，测量其 AC 1KHz 下的交流阻抗	$\leq 80\text{m}\Omega$
6	Temperature Characteristics 温度特性	1. According to item 5.5, at $25 \pm 5^\circ\text{C}$. 2. Capacity comparison at each temperature, measured with constant discharge current 0.2C with 3.0V cut-off. Percentage as an index of the capacity compared with 100% at 25°C 1. 在 $25 \pm 5^\circ\text{C}$ 条件下，用 5.5 方法将电芯充电。 2. 在不同温度条件下，用 0.2C 的电流恒流放电至截止电压 3.0V。以 25°C 时放电容量为基准计算百分比。	-20°C : $\geq 50\%$ 25°C : 100% 50°C : $\geq 85\%$

文件名称 File Name	文件编号 DOC NO	客户代码 Code	版本	日期 Date	产品类别 Product category	页码
产品规格书	FUXY/SPC-00260		1.0	2019/01/04	聚合物锂离子充电电池	8/13

6.2 Mechanical characteristics

机械特性

NO.	Items	Test Method and Condition	Criteria
1	Vibration Test 振动测试	After standard charging, fixed the cell to vibration table and subjected to vibration cycling that the frequency is to be varied at the rate of 1Hz per minute between 10Hz and 55Hz, the FUXYursion of the vibration is 1.6mm.The cell shall be vibrated for 30 minutes per axis of XYZ axes. 将标准充电后的电池固定在振动台上，沿 X、Y、Z 三个方向各振动 30 分钟，振幅 1.6 mm，振动频率为 10Hz~55Hz，每分钟变化为 1Hz。	No leakage 无泄漏 No fire 不起火
2	Drop Test 跌落测试	The cell is to be dropped from a height of meter twice onto concrete ground. 将标准充电后的电芯从 1 米高度跌落至混凝土地面 2 次	No fire, no leakage. 无起火、无泄漏

6.3 Visual inspection

There shall be no such defect as scratch, flaw, crack, and leakage, which may adversely affect commercial value of the cell.

外观检查

不允许有任何影响电芯性能的外观缺陷，诸如裂纹、裂缝、泄漏等。

6.4 Standard environmental test condition

Unless otherwise specified, all tests stated in this Product Specification are conducted at below condition:

Temperature: $25 \pm 5^{\circ}\text{C}$

Humidity: $\leq 75\% \text{RH}$

标准测试环境

除非特别说明，本标准书中所有测试均在以下环境条件下进行：

温度： $25 \pm 5^{\circ}\text{C}$

湿度： $\leq 75\% \text{RH}$

文件名称 File Name	文件编号 DOC NO	客户代码 Code	版本	日期 Date	产品类别 Product category	页码
产品规格书	FUXY/SPC-00260		1.0	2019/01/04	聚合物锂离子充电电池	9/13

7.Parameter of PCB

保护板参数

7.1 List of Parameter

保护板参数清单

Parameter	Symbol	Remark	Min	Typ.	Max	Unit
Overcharge Detection Voltage	VDET1	CSI=0	4.25	4.3	4.35	V
Overcharge Detection Delay Time	TVDDET1	CTD=0.01	80	100	200	ms
Over discharge Detection Voltage	VDET2	CSI=0	2.35	2.45	2.55	V
Over discharge Detection Delay Time	TVDET2	VDD=3.6V->2.0V	5	13	20	ms
Over Current Defection	ID		1.5		3	A
Over Current Detection Delay Time	TVDET3	VDD=3.6V	5	13	20	ms
short circuit Detection Delay Time	TSHORT	VDD=3.6V		5	50	μ S
Current Consumption in Normal	IDD	VDD=3.9V V=0V	0.3		6	μ A
Impedance	RD	VDD=4.0V		40	60	m Ω

文件名称 File Name	文件编号 DOC NO	客户代码 Code	版本	日期 Date	产品类别 Product category	页码
产品规格书	FUXY/SPC-00260		1.0	2019/01/04	聚合物锂离子充电电池	10/13

7.2 List of PCB BOM

主要原件清单

Item	Reference	Description	Type	Qty
1	U1	CONTROL IC	DW01, 封装 SOT-23-6	1
2	U2	MOSFET	8205A	1
3	R1	RES	100 Ω	1
4	R2	RES	1K Ω	1
5	C1	CAP	0.1uF	1
6		PCB	双面板, PCB 厚 0.65mm,	1

7.3 Dimension of PCB

注：保护板的长度正负公差±0.15mm，宽度正负公差±0.10mm，厚度正公差 0.10mm

顶层：

3.6mm ± 0.15mm



底层：

16mm ± 0.15mm



文件名称 File Name	文件编号 DOC NO	客户代码 Code	版本 版本	日期 Date	产品类别 Product category	页码
产品规格书	FUXY/SPC-00260		1.0	2019/01/04	聚合物锂离子充电电池	11/13

保护板装配示意图：

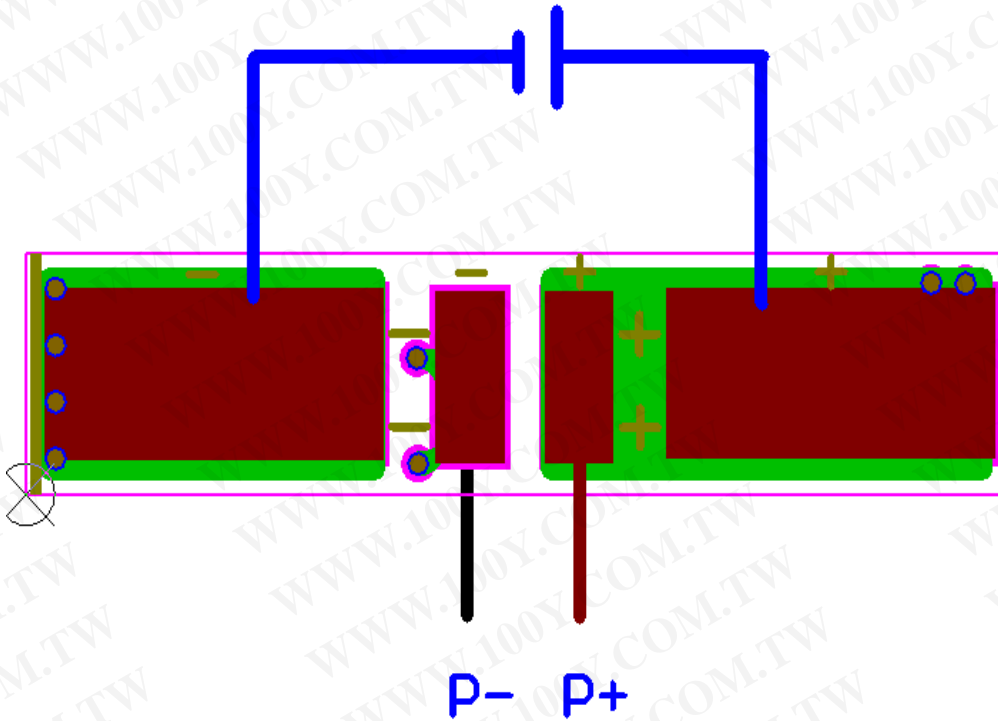

7.4 Circuit Diagram

原理图

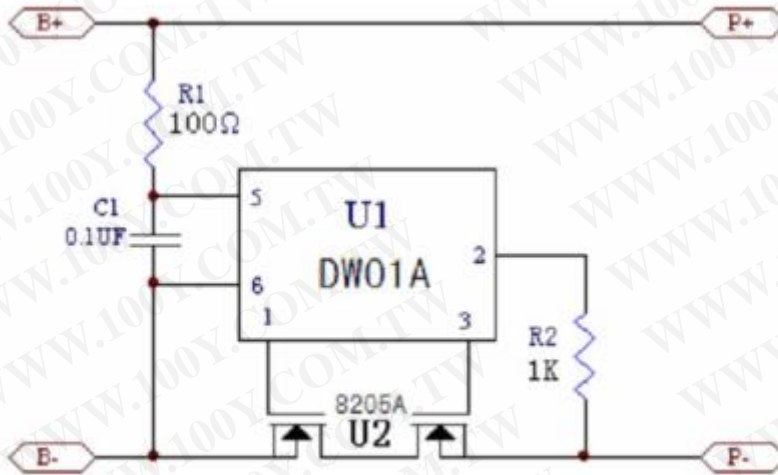

文件名称 File Name	文件编号 DOC NO	客户代码 Code	版本	日期 Date	产品类别 Product category	页码
产品规格书	FUXY/SPC-00260		1.0	2019/01/04	聚合物锂离子充电电池	12/13

7.5 PACK Battery External Dimension Drawing

电池尺寸示意图

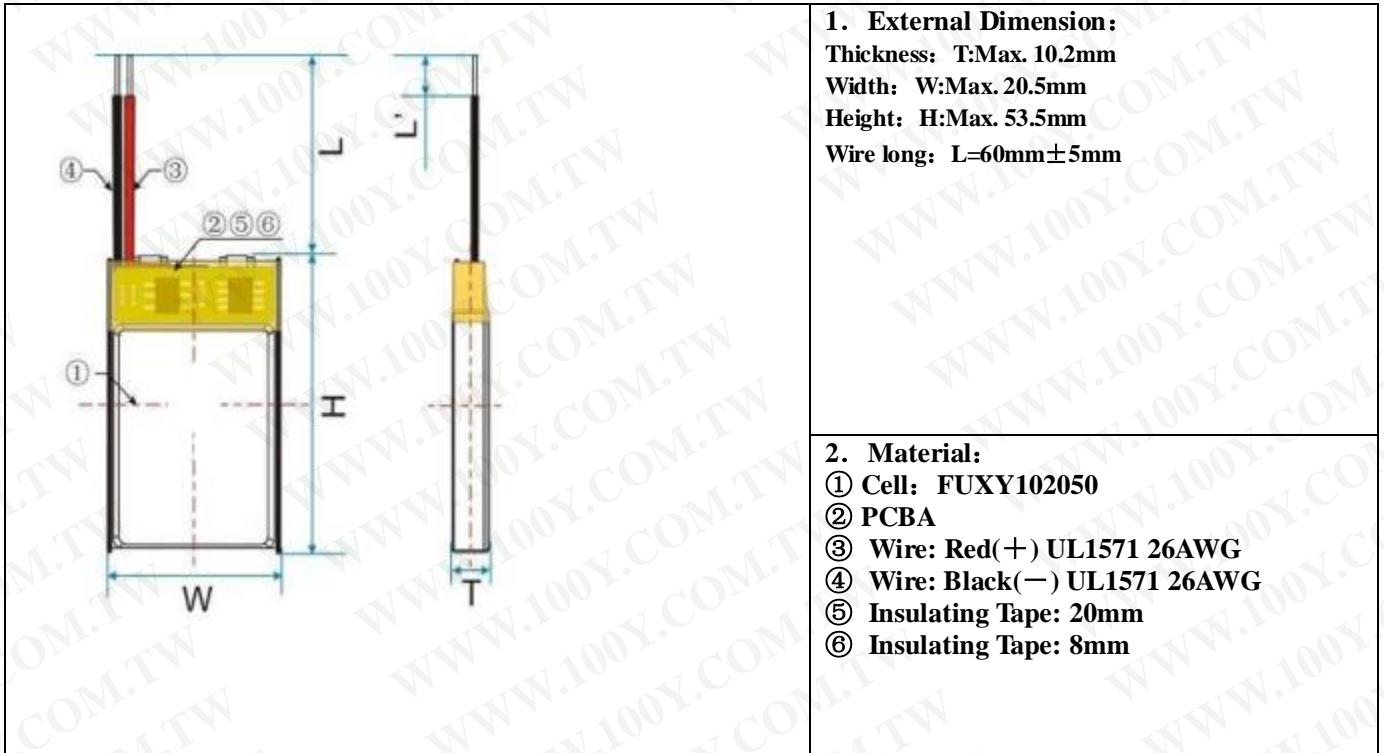

文件名称 File Name	文件编号 DOC NO	客户代码 Code	版本	日期 Date	产品类别 Product category	页码
产品规格书	FUXY/SPC-00260		1.0	2019/01/04	聚合物锂离子充电电池	13/13

8. Guarantee Period of Quality

质量保证期

Guarantee period of quality is 12 months after sold.

保质期为 12 个月。

8. 1. Storage and Others

贮存及其它事项

a) Long Time Storage

If the Cell is stored for a long time, the cell's storage should be 3.6~3.9V and the cell is to be stored in a condition as No.5.11。

长期贮存

长期贮存的电芯（超每隔 3 个月）须充电一次、置于干燥、凉爽处。贮存电压为 3.6~3.9V 且贮存环境要求如 5.11。

b) Others

Any matters that this specification does not cover should be conferred between the customer and Fuxinyuan.

其它事项

任何本说明书中未提及的事项，须经双方协商确定。